

# Power Distribution Enclosure

## Overview

- Robust IP55 enclosure system to house street lighting cut outs and isolators
- Suitable for mounting on wooden or steel posts and directly to buildings
- Custom circuit configurations available on request

## Features

- Large internal volume allows flexibility for multiple circuit configurations
- Unit will house all standard Lucy Zodion Titan and Trojan units
- Two Pg plastic glands supplied (for incoming and outgoing cables)
- Supplied with both metal bracket for post mounting or four lugs for wall mounting
- Wide door opening >90deg
- Wooden mounting backboard
- Single tri-head door lock (7mm)



## Custom Options

- Alternative internal mounting plates in a variety of materials
- Customer specific gland plates to cater for all cable types
- Padlock facility
- Two pin lock
- Customer specific circuit configurations

## Table of versions

Part Code	Description
THM0047241	Type A - Overhead line termination box with 25amp Street lighting cut out
THM0047253	Type B - Festive lighting control box with external socket
THM0047251	Type C - Festive lighting control box without external socket
THM0047881	Type D - Overhead line termination with 100amp house service unit



**THORNE &  
DERRICK  
INTERNATIONAL**

**Thorne & Derrick**  
+44 (0) 191 410 4292  
[www.powerandcables.com](http://www.powerandcables.com)

# Power Distribution Enclosure



## Construction

- Glass reinforced polyester, colour RAL 7035 (Grey)
- One piece body with integral seal
- One piece door with two hinges
- Standard tri-head door lock (key not supplied)

## Performance

- Ingress protection to IP55
- Shock resistance IK10
- 960C self-extinguishing
- Resistant to chemical agents and UV degradation

## Recommended settings

- Factory pre-wired and tested
- Supplied 'ready to install' - straight out of the box

## Conformity to Standards

- CEI 60529
- CEI 62262
- CEI 60695-2-10

## Weight (kgs)

- 2.2kg to 2.8kg depending on internal equipment specified

## Dimensions

- Height = 300mm
- Width = 248mm
- Depth = 165mm

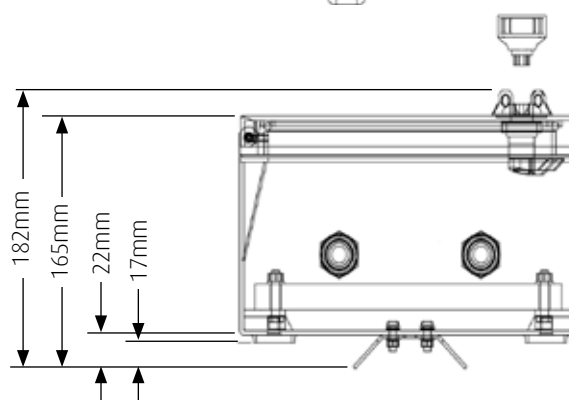
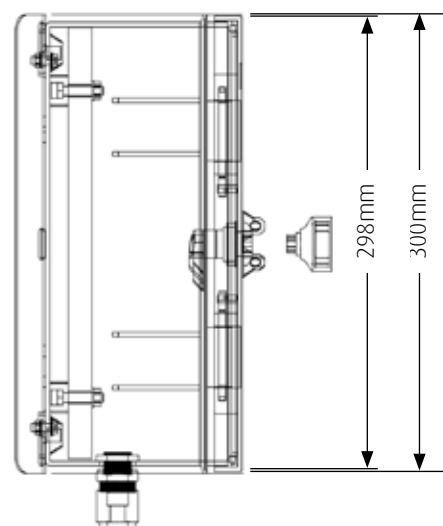
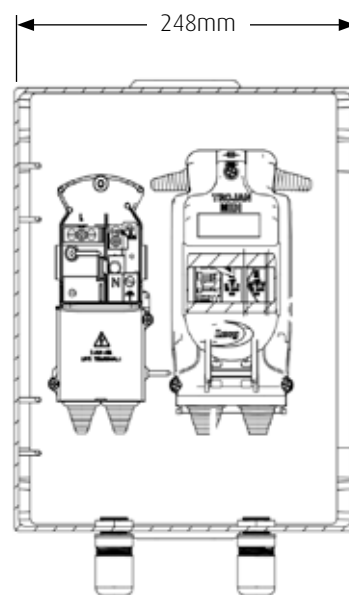

THORNE &  
**DERRICK**  
INTERNATIONAL

Thorne & Derrick  
+44 (0) 191 410 4292  
[www.powerandcables.com](http://www.powerandcables.com)