



14 M 174 E

Cembre



Certified Quality
Management System



Certified Environmental
Management System



Certified Occupational
Health & Safety
Management System

ENGLISH

BATTERY OPERATED HYDRAULIC CRIMPING TOOL





B54MD-D6
B54MD-D6E

**OPERATION AND MAINTENANCE
MANUAL**





WARNING LABELS

Tool

	<p><i>Before using the tool, carefully read the instructions in this manual.</i></p>
	<p><i>When operating the tool, keep hands away from the danger zone.</i></p>
	<p><i>See page 8.</i></p>

Battery

	<p><i>Never throw batteries into fire or water.</i></p>
	<p><i>Always recycle the batteries.</i></p>
	<p><i>Do not discard batteries into domestic refuse or waste disposal.</i></p>

BATTERY OPERATED HYDRAULIC CRIMPING TOOL

1. GENERAL CHARACTERISTICS

TOOL TYPE:	B54MD-D6	B54MD-D6E
Application range:	suitable for installing electrical compression connectors for conductors up to 150 mm ² (300 MCM)	
Crimping force kN (sh ton):	54 (6)	
Rated operating pressure bar (psi):	340 (4,900)	
Dimensions LxWxH mm (inches):	458 x 133 x 81 (18 x 5.2 x 3.2)	
Weight with battery kg (lbs):	2,95 (6.5)	
Motor Volt DC:	18	
Battery type CB1820L Volt / Ah:	18 / 2.0 Li-Ion	
Battery charger supply Volt / Hz:	220-240 / 50-60	
Recommended oil:	AGIP ARNICA 22 or ESSO INVAROL EP22 or equivalent.	
Safety:	the tool is equipped with a maximum pressure valve.	
Types of jaw supplied:	CDD 6 with D3 groove to accept all "W" style crimping dies + "BG" fixed groove	
Acoustic Noise (Directive 2006/42/EC, annexe 1, point 1.7.4.2 letter u) – The weighted continuous acoustic pressure level equivalent A at the work place L_{pA} is equal to 64,9 dB (A) – The maximum value of the weighted acoustic displacement pressure C at the work place L_{pCPeak} is equal to 99,7 dB (C) – The acoustic power level emitted by the machine L_{WA} is equal to 69,3 dB (A)		
Risks due to vibration (Directive 2006/42/EC, annexe 1, point 2.2.1.1) Tests carried out in compliance with the indications contained in UNI ENV 25349 and UNI EN 28662 part 1 st Standards, and under operating conditions much more severe than those normally found, certify that the weighted root mean square in frequency of the acceleration the upper limbs are exposed to for each biodynamic reference axis is 0,527 m/sec ² max.		

INTERCHANGEABLE CRIMPING JAWS

JAW TYPE	GROOVES	CRIMPING DIE COMPATIBILITY	
CDD6	"D3" TO ACCEPT ALL "W" STYLE CRIMPING DIES + "BG" FIXED GROOVE	FCI Burndy Greenlee IlSCO Huskie Panduit	W, X Series KD6 Series ND Series HT-58 Series CD-2001 series

2. INSTRUCTIONS FOR USE

The tool can be held in one hand while positioning the connector with the other. Residual battery capacity level is automatically displayed after every cycle.

The part reference includes the following:

- Basic tool complete with crimping jaws with thermoplastic protection.
- Spare battery.
- Battery charger.
- Plastic carrying case type VAL P45.

2.1) Preparation

With the tool in the rest position (the ram fully retracted) proceed as follows:

- Select the appropriate groove or die set for the connector to be crimped.
- Insert the dies into the jaws of the tool (see § 2.8).
- Insert the conductor into the connector.

2.2) Die advancement (Ref. to Fig. 1)

Grip the tool firmly and comfortably.

- Position the connector in the die groove and ensure the correct location of the crimp.
- Press operating button (4) to activate the motor-pump group for the advancement of the ram. To halt the advancement, release the operating button and the motor will cut out.

Make sure the dies are exactly positioned on the desired crimp point otherwise re-open dies following instructions as per § 2.5 and reposition the connector.



FIG. 1

2.3) Compression

Insert the conductor in the connector and press the operating button (4); the ram will gradually move forward until the two dies touch. It is recommended to keep operating until the maximum pressure valve is activated and a "click" is heard.

2.4) Head rotation

For ease of operation the tool head can rotate through 180°, allowing the operator to work in the most comfortable position.

Warning: do not attempt to rotate the head when the hydraulic circuit is pressurised.

2.5) Release of dies

Press the pressure release button (9), the ram will retract and open the jaws.

2.6) Battery status (Ref. to Fig. 2)

The battery is equipped with LED indicators that indicate the remaining battery life at any time by pressing the adjacent button (P).

4 LEDs illuminated: Fully charged

2 LEDs illuminated: 50 % capacity

1 LED flashing: Minimum charge, replace the battery

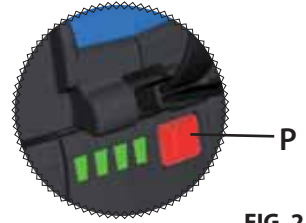

FIG. 2

2.7) Insertion/replacement of battery

To replace the battery, remove it by pressing the release button (15) (Ref. to Fig. 3), then insert the new battery, sliding it into the guides until it locks.



FIG. 3



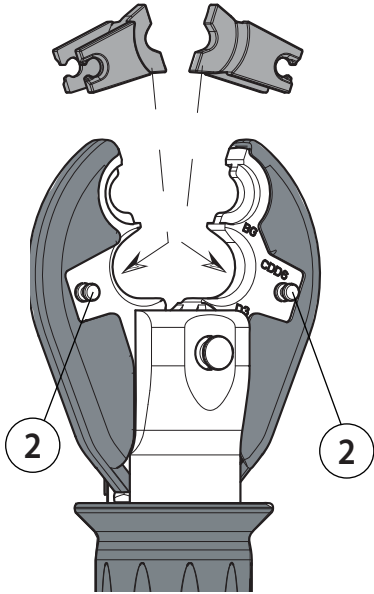

FIG. 4

2.8) "W" style crimping dies assemblies

- Press pins (2) and insert "W" dies into their seats (see Fig. 4).
- To disassemble them simply press the pins and slip them from the jaws.

⚠ IT IS RECOMMENDED TO USE THE TOOL ONLY WITH PRODUCT TO BE CRIMPED INSERTED.

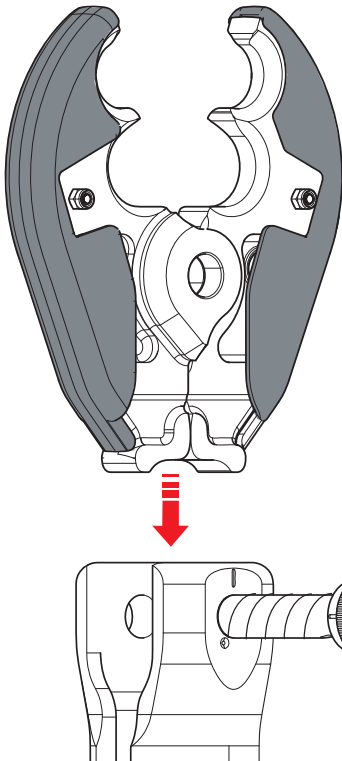
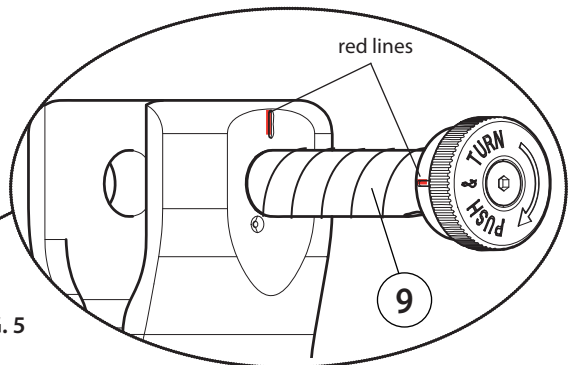

FIG. 5

2.9) Jaw replacement



The tool is supplied with the interchangeable CDD 6 jaw. Other types of jaw can also be supplied separately, for replacement proceed as follows:

- Push and turn clockwise the locking pin (9) so that the jaws are released.
- Slide the jaws out of the top of the tool and insert the new ones (see Fig. 5).
- Fully insert the locking pin (9) into the tool and lock it by turning clockwise until the red lines are aligned.



3. WARNING

Before starting work on electrical equipment, please ensure that either there are no live parts in the immediate working area or that precautions are taken for working near live parts in accordance with EN50110-1.

-  **DO NOT USE THIS TOOL ON OR NEAR ENERGISED CONDUCTORS WITHOUT PROPER PERSONAL PROTECTIVE EQUIPMENT. FAILURE TO OBSERVE THIS WARNING COULD RESULT IN SEVERE INJURY OR DEATH.**
-  **THE TOOL IS UNSUITABLE FOR CONTINUOUS USE AND SHOULD BE ALLOWED TO COOL DOWN FOLLOWING UNINTERRUPTED, SUCCESSIVE CRIMPING OPERATIONS; FOR INSTANCE, HAVING EXHAUSTED A FULLY CHARGED BATTERY IN ONE SESSION, DELAY BATTERY REPLACEMENT FOR A FEW MINUTES. OBSERVE RECOMMENDED REST PERIODS ALSO WHEN USING AN EXTERNAL POWER SUPPLY.**
-  **PROTECT THE TOOL FROM RAIN AND MOISTURE. WATER WILL DAMAGE THE TOOL AND BATTERY. ELECTRO-HYDRAULIC TOOLS SHOULD NOT BE OPERATED IN POURING RAIN OR UNDER WATER.**

3.1) Using the battery charger

Carefully follow the instructions in the battery charger manual.

4. MAINTENANCE

The tool is robust, completely sealed and requires very little daily maintenance. Compliance with the following points should help to maintain the optimum performance of the tool:

4.1) Thorough cleaning

Dust, sand and dirt are a danger for any hydraulic device.

Every day, after use, the tool must be wiped with a clean cloth taking care to remove any residue, especially close to moveable parts.

4.2) Storage

When not in use, the tool should be stored and transported in the plastic case, to prevent damage. The case is suitable for storing the tool, the accessories and die sets.

Plastic case: **VAL P45**, size 497x370x137 mm, (19.5x14.5x5.4 inches) weighs 2,3 kg (5 lbs.).



5. RETURN TO Cembre FOR OVERHAUL

In the case of a breakdown contact our Area Agent who will advise you on the problem and give you the necessary instructions on how to dispatch the tool to our nearest service Centre; if possible, attach a copy of the Test Certificate supplied by **Cembre** together with the tool or, if no other references are available, indicate the approximate purchase date and the tool serial number.

- Following information applies in member states of the European Union:

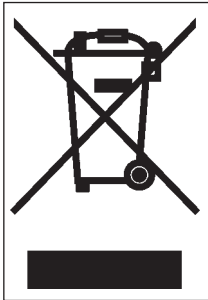

USER INFORMATION in accordance with “Directives 2002/95/EC and 2002/96/EC regarding the reduction of hazardous substances in electrical and electronic equipment, including the disposal of waste”.

The 'Not in the bin' symbol above when shown on equipment or packaging means that the equipment must, at the end of its life, be disposed of separately from other waste.

The separate waste collection of such equipment is organised and managed by the manufacturer.

Users wishing to dispose of such equipment must contact the manufacturer and follow the prescribed guidelines for its separate collection.

Appropriate waste separation, collection, environmentally compatible treatment and disposal is intended to reduce harmful environmental effects and promote the reuse and recycling of materials contained in the equipment.

Unlawful disposal of such equipment will be subject to the application of administrative sanctions provided by current legislation.

SPARE PARTS LIST

*The guarantee is void if parts used are not **Cembre** original spares.*

When ordering spare parts always specify the following:

- code number of item
- name of item
- type of tool
- serial number of tool

TABLE 1 (JAW)

Code N°	Item	DESCRIPTION	Qty
6000630	1	RUBBER COVER	2
6600022	2	DIE RETAINER PIN	2
6520404	3	SPRING	2
6520630	4	SPRING	1
6180171	5	M3 AUTOLOCK NUT	2
6760085	6	Ø 3x12 ELASTIC PIN	2

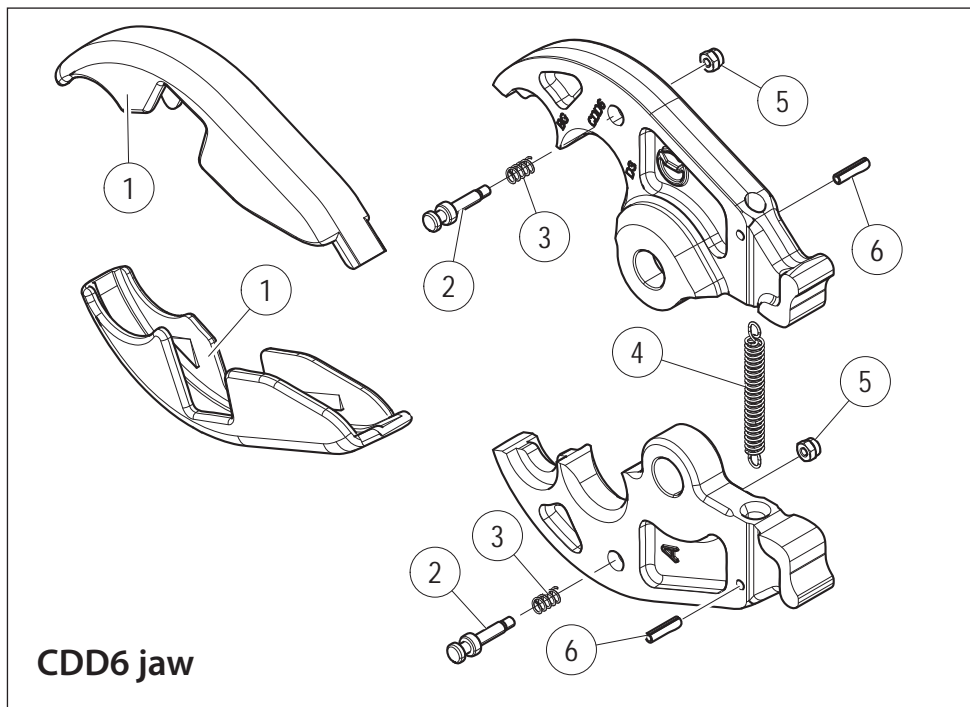

TABLE 2

Code N°	Item	DESCRIPTION	Qty
6000577	1	BODY RIGHT+LEFT SHELL	1
6000128	2	BATTERY ADAPTER SHELL R+L	1
2598495	3	BATTERY CB1820L Li-Ion 18V 2Ah	1
6000217	4	OPERATING BUTTON	1
6000127	5	SHUTTER	1
6000591	6	ROD	1
6000593	7	SPRING	1
6000150	8	CONTACT SUPPORT	1
6000218	9	PRESSURE RELEASE BUTTON	1
6000582	10	BUTTON STRIKER	1
6000200	11	MECHANICAL GROUP	1
6004168	12	COMPLETE ELECTRICAL CIRCUIT	1
6000126	13	SHUTTER	1
6000589	14	WRIST STRAP	1
6006280	15	BATTERY RELEASE	1
6900650	16	3,5X16 SCREW	8
6520531	17	SPRING	1
6232755	18	TG.0999 LABEL	1
6232500	19	TG.0704 LABEL	1
6232676	20	TG.0919 LABEL	2

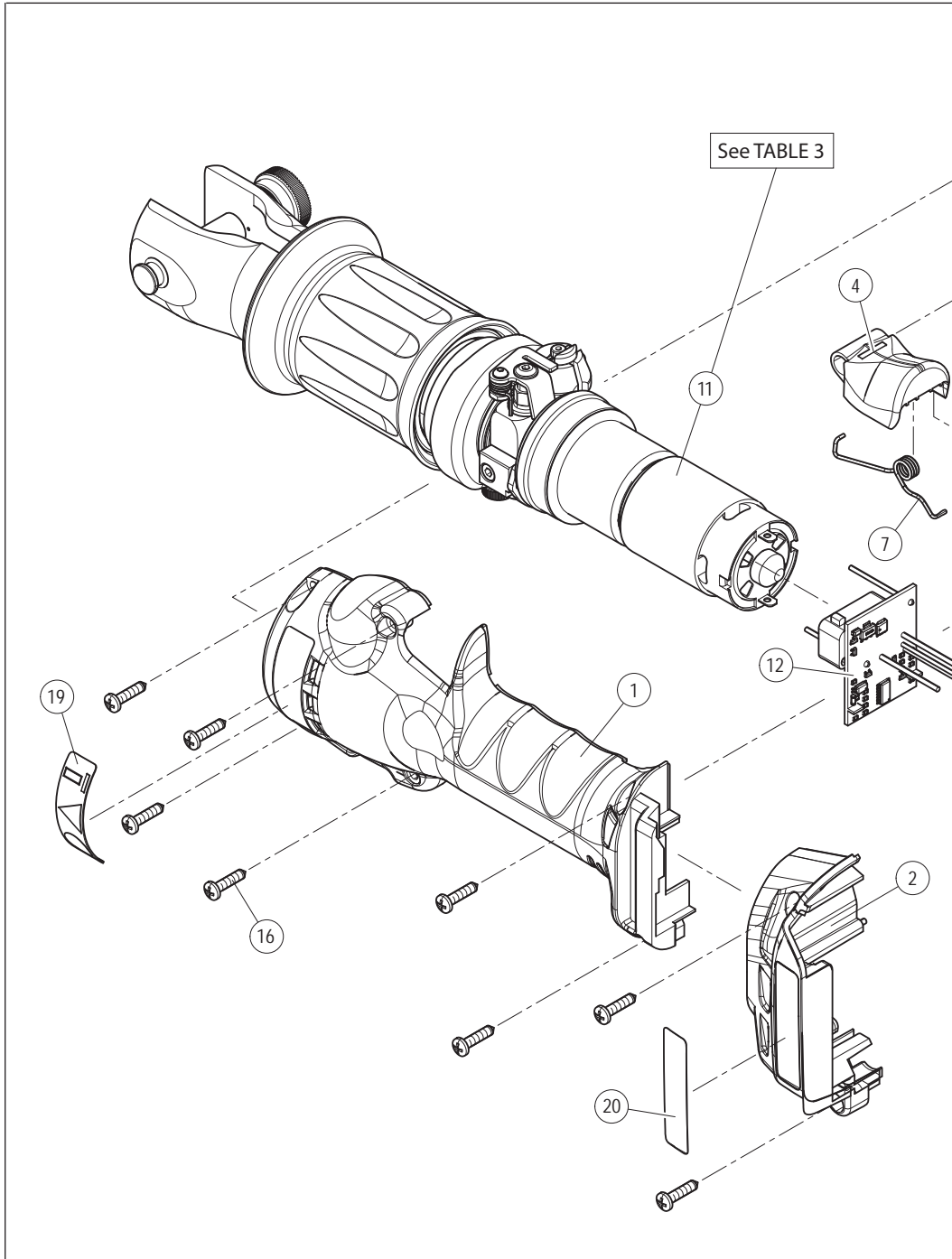

TABLE 2

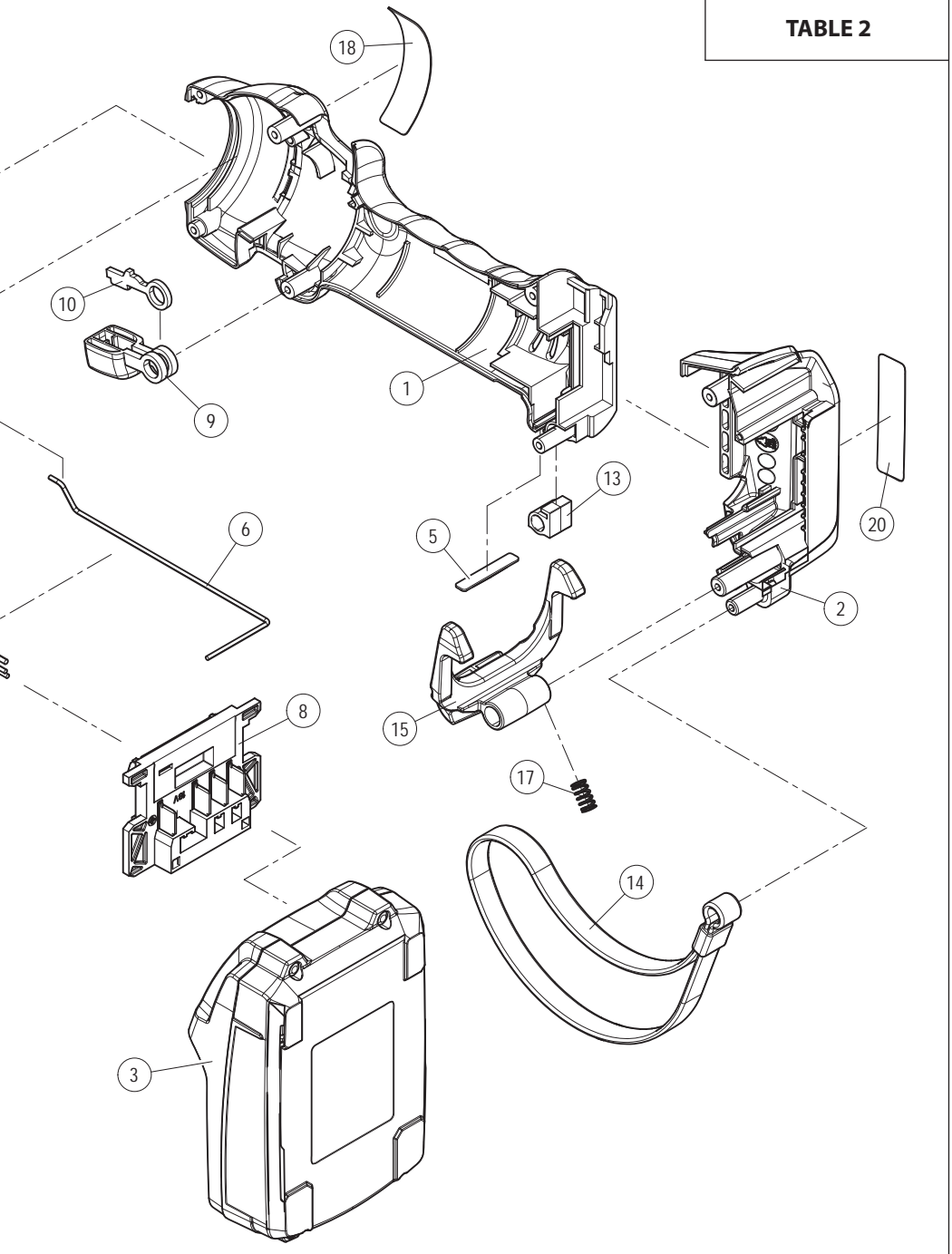

TABLE 3 (ITEM 11 IN TABLE 2)

Code N°	Item		DESCRIPTION	Qty
6000625	90		RUBBER GRIP	1
6000199	100		ACTUATING MECHANICAL GROUP	1
6000357	100	1	HOUSING	1
6000358	100	4	GEAR	1
6760004	100	8	Ø 2X8 CYLINDRICAL PIN	3
6900008	100	9	M3x6 SCREW	2
6000849	100	10	Ø 3 SCHNORR WASHER	2
6740020	100	11	1/4" BALL	2
6000363	100	15	GEAR	3
6402009	100	16	BEARING	1
6402006	100	17	WASHER	1
6000328	100	18	WASHER	1
6760012	100	19	CYLINDRICAL PIN	2
6000315	100	20	SPACER	3
6000231	100	210	COMPLETE DISC	1
6000229	100	6	DISC	1
6000227	100	7	BALLS SUPPORT	1
6700080	100	8	Ø 6 CIRCLIP	1
6650136	100	9	WASHER	1
6000232	100	220	COMPLETE CAM	1
6000198	100	250	COMPLETE MOTOR	1
6000152	300		COMPLETE HYDRAULIC GROUP	1
6620122	300	1	RAM	1
6362098	300	11	SEAL	1
6000560	300	15	MEMBRANE RING	1
6720072	300	16	OIL RESERVOIR	1
6300027	300	17	VALVE PISTON	1
6000561	300	18	GRUB SCREW	1
6520232	300	19	VALVE SPRING	1
6620378	300	21	PUMPING RAM	1
6000563	300	24	VALVE ROD	1
6000575	300	26	SPRING SUPPORT	1
6000565	300	27	TEST PRESSURE CAP	1
6641027	300	30	WASHER	1
6000567	300	31	SETTING VALVE LOCKNUT	1
6000603	300	45	PRESSURE RELEASE LEVER	1
6000570	300	57	PUMPING RAM RETURN SPRING	1
6740100	300	62	5/32" BALL	1
6520160	300	63	SPRING	1
6340590	300	64	GRUB SCREW	1

TABLE 3 (ITEM 11 IN TABLE 2)

Code N°	Item		DESCRIPTION	Qty	
6520200	300	65	SPRING	1	
6740120	300	66	7/32" BALL	1	
3041735	300	67	TIE	2	
6640205	300	68	D. 4 SCHNORR WASHER	1	
6900052	300	69	M4x6 SCREW	1	
6000602	300	70	LEVER SPRING	1	
6900054	300	71	M4x6 SCREW	1	
6360022	300	72	O-RING	1	
6360125	300	75	O-RING	1	
6641020	300	77	Ø 6 CU WASHER	1	
6000318	300	78	SPRING GUIDE	1	
6160081	300	310	BODY	1	
6000153	300	350	RESERVOIR CAP	1	
6000588	300	360	COMPLETE LEVER SUPPORT	1	
6000601	300	400	COMPLETE MEMBRANE	1	
6900602	300	500	COMPLETE SUCTION SCREW	1	
6000620	600		COMPLETE JAW SUPPORT	1	
6000621	600	2	SUPPORT	1	
6000632	600	3	ROLL	2	
6560200	600	4	PIN ROLL	2	
6000622	600	5	JAWS SUPPORT	1	
6000623	600	6	SPRING	1	
6040564	600	7	RAM GUIDE RING	1	
6000624	600	8	PIN GRIP	1	
6000633	600	9	JAW LOCKING PIN	1	
6700051	600	12	Ø 10 CIRCLIP	1	
6900013	600	13	M3x4 SCREW	1	
6520030	600	14	RAM RETURN SPRING	1	
6520601	600	15	SPRING	1	
6760420	600	16	CYLINDRICAL PIN	1	
6900180	600	17	M4x10 SCREW	1	

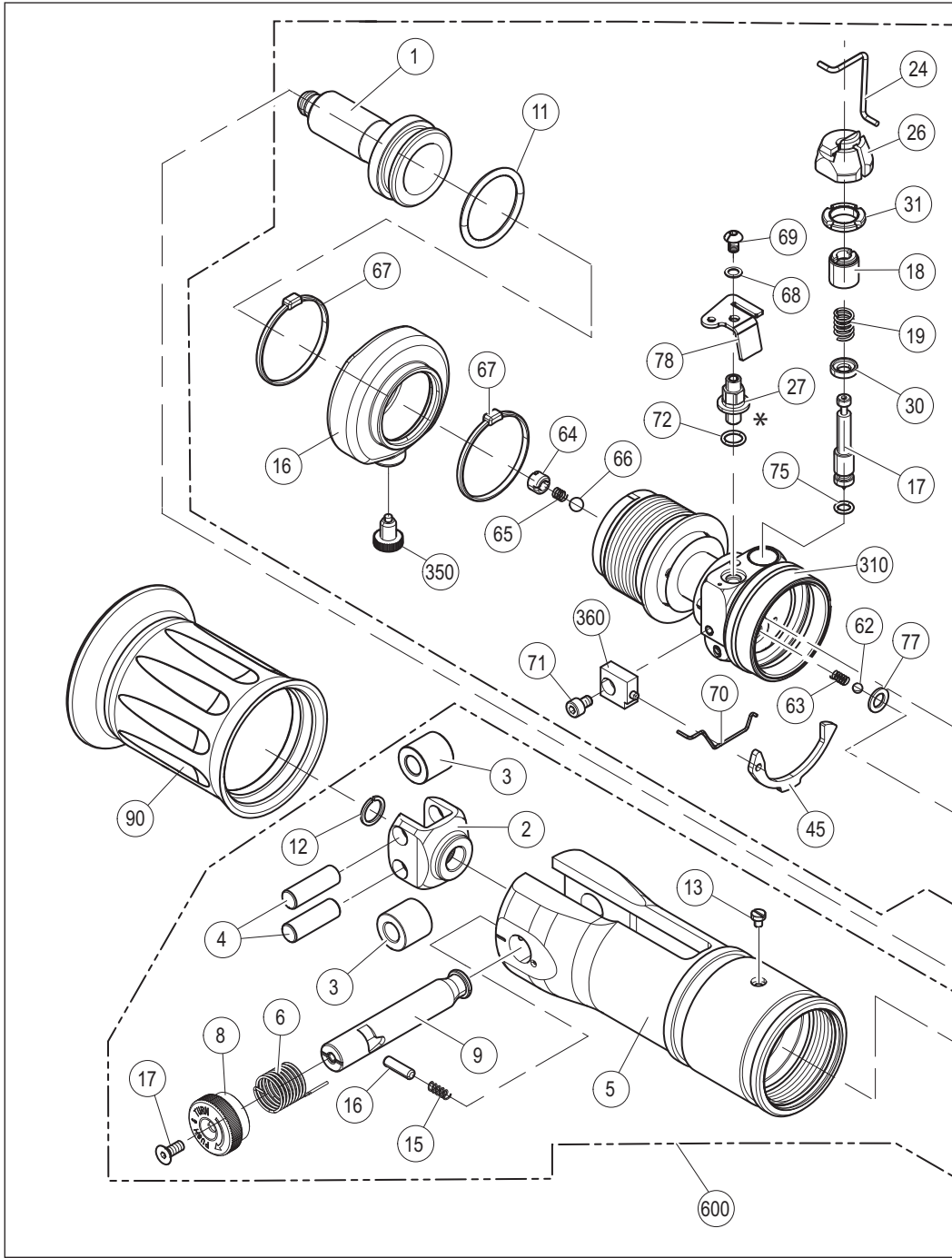
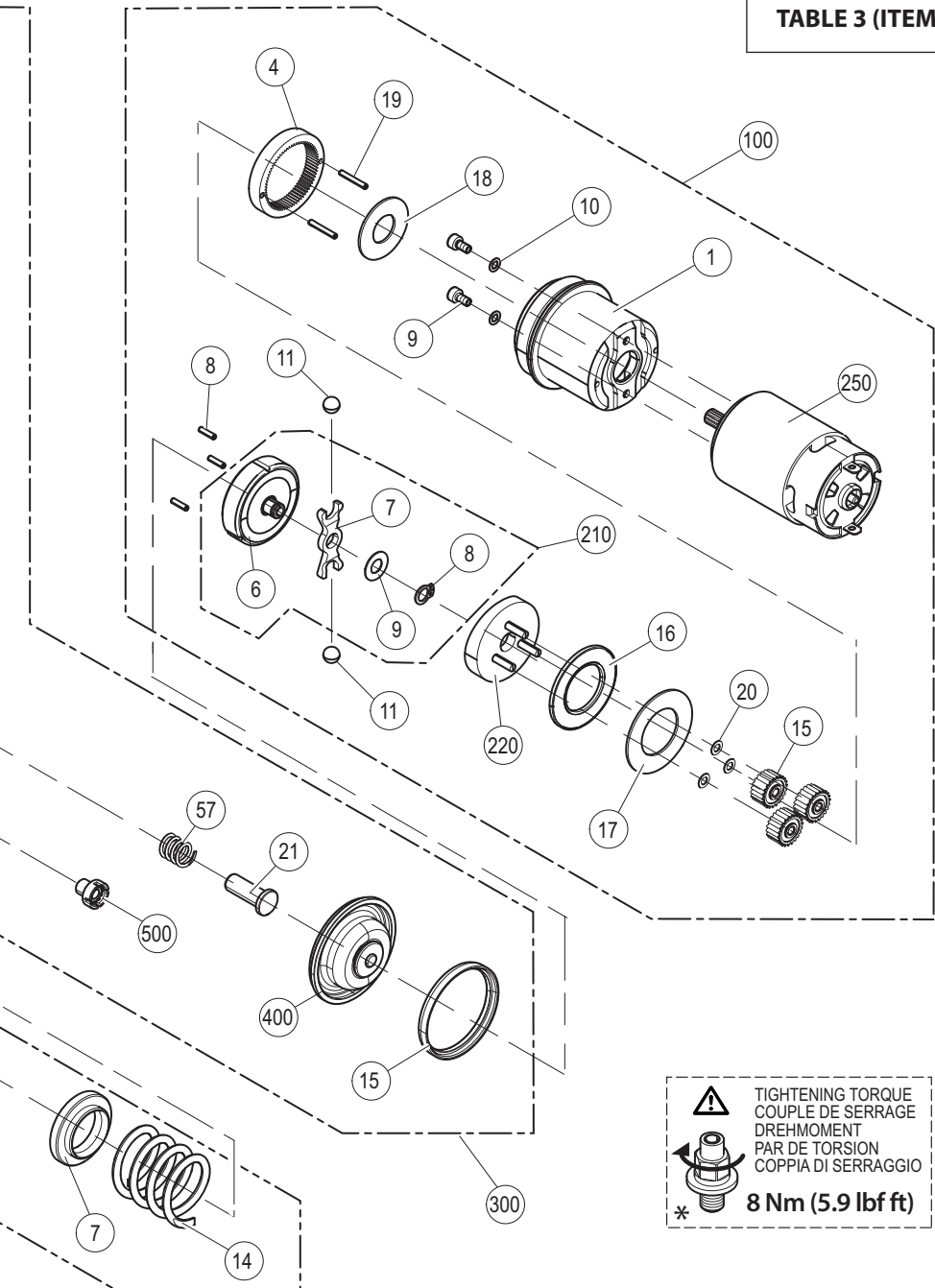

TABLE 3 (ITEM 11)





Cembre S.p.A.
Via Serenissima, 9
25135 Brescia (Italia)
Telefono: 030 36921
Telefax: 030 3365766
E-mail: sales@cembre.com
www.cembre.it

Cembre Ltd.
Dunton Park
Kingsbury Road, Curdworth - Sutton Coldfield
West Midlands B76 9EB (Great Britain)
Tel.: 01675 470440 - Fax: 01675 470220
E-mail: sales@cembre.co.uk
www.cembre.co.uk

Cembre S.a.r.l.
22 Avenue Ferdinand de Lesseps
91420 Morangis (France)
Tel.: 01 60 49 11 90 - Fax: 01 60 49 29 10
B.P. 37 - 91421 Morangis Cédex
E-mail: info@cembre.fr
www.cembre.fr

Cembre España S.L.
Calle Verano, 6 y 8 - P.I. Las Monjas
28850 Torrejón de Ardoz - Madrid (España)
Telefono: 91 4852580
Telefax: 91 4852581
E-mail: comercial@cembre.es
www.cembre.es

Cembre AS
Fossnes Senter
N-3160 Stokke (Norway)
Phone: (47) 33361765
Telefax: (47) 33361766
E-mail: sales@cembre.no
www.cembre.no

Cembre GmbH
Heidemannstraße 166
80939 München (Deutschland)
Telefon: 089/3580676
Telefax: 089/35806777
E-mail: sales@cembre.de
www.cembre.de

Cembre Inc.
Raritan Center Business Park
181 Fieldcrest Avenue
Edison, New Jersey 08837 (USA)
Tel.: (732) 225-7415 - Fax: (732) 225-7414
E-mail: Sales.US@cembreinc.com
www.cembreinc.com