

EDITION 2014

CABLE SYSTEMS

Cable fittings for medium voltage networks

THE POWER CONNECTION



Cable Fittings for Medium Voltage Networks.

Our range of cable accessories offers solutions for virtually all applications in the area of medium voltage engineering. All accessories use silicone rubber as insulating medium because of its outstanding properties. We offer components and complete systems.

MV-CONNEX. A Dry, Separable Connector System for Medium Voltage Networks.

CONNEX meets all your requirements to an universal system of separable connectors: fully insulated with metal housing and providing touch-proof properties. It is maintenance-free, suitable for outdoor use and waterproof. This means MV-CONNEX can be used even in the most extreme conditions.

MV-CONNEX components are factory tested and are surprisingly simple to install. Complex oil and gas work during installation and commissioning of transformers and switchgears are finally a thing of the past.

MV-CONNEX for medium voltage systems comes in a wide range of variations. It includes traditional plug and socket combinations, multiple sockets, bus-bar connectors, surge arresters and voltage detecting systems.



Silicone – a Key Material in Medium Voltage Engineering.

Water, dirt, grease and oil-resistant, completely maintenance-free, shock-resistant and unbreakable: silicone rubber is the perfect material for cable terminations and far superior to traditional materials such as porcelain. When used as a stress-relief device in sealed applications, silicone evens out temperature variations and unevenness in the cable surface

much better than harder materials such as EPDM do. Dangerous partial discharges caused by air gaps are safely avoided. PFISTERER makes silicone products primarily using advanced LSR (Liquid Silicone Rubber) designs; special variations are designed using RTV (Room-Temperature Vulcanizing Silicone).

Continuous voltage indicator for enclosed equipment.

With the increasing use of enclosed switchgear, voltage testing systems, that indicate the presence of voltage without directly contacting live parts, are becoming increasingly important. The principle of the DSA continuous voltage indicator that was

developed by us has become a standard. In line with the trend towards integrated systems we have incorporated these plug-in display devices in the compact DSA-i3 system.

MV-CONNEX Pluggable Connection System

Page | 8 – 65

I

Voltage Detecting Systems

Page | 66 – 71

II

MV-CONNEX Pluggable Connection System

Voltage Detecting Systems



MV-CONNEX
Separable Connectors
Page 10 – 16



Accessories
Page 17 – 30



MV-CONNEX
Transformer Bushings
Page 31 – 44



MV-CONNEX
Bushings, Sockets,
Insulators
Page 45 – 50



Bus Bar
Coupling System
Page 51 – 52



MV-CONNEX
Connecting and
Branching System
Page 53 – 55



MV-CONNEX Earthing and
Short-Circuit Devices
Page 56 – 57



MV-CONNEX
Surge Arresters
Page 58 – 61



MV-CONNEX
CMA- and CMS-System
Page 62 – 65



Indicators
Page 66 – 68



Interfaces and
Connecting Leads
Page 69



Testers
Page 70 – 71

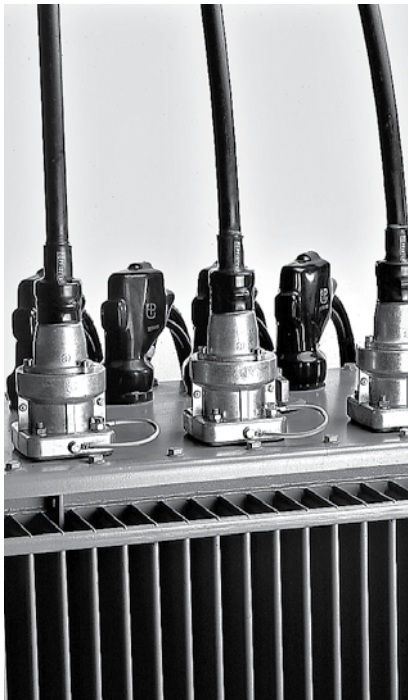

MV-CONNEX up to 52 kV

The MV-CONNEX range is ideal for use in ring main units, circuit-breaker switchgear, high-voltage motors, transformers, capacitors, transducers and sealing boxes. The connectors on the equipment-side are designed to meet EN 50180, 50181, and DIN 47637. The plug is suitable for all kinds of insulated plastic cables. As well as a wide range of standard types there are also customer-specific versions for every cable type. The MV-CONNEX system features numerous variations: in addition to the standard plug and socket combination, there are many other versions for testing purposes and special applications.

Advantages

- no liquid insulating medium
- no need to open the cable termination at the installation site
- deckwater-proof
- suitable for outdoor use
- thorough transformer and GIS testing by manufacturer possible
- metal enclosed
- fully insulated
- touch proof
- free from arcing
- high short-circuit protection
- maintenance free
- soil- and offshore-proof (optional)

A Contact system

- 1 contact ring
- 2 tension cone
- 3 thrust piece

B Insulating and field-control part

C Housing

- 4 bell flange
- 5 pressure sleeve
- 6 pressure spring
- 7 heat-shrink
- 8 test lead (depends on design)
- 9 cable screen

D Socket

- 10 female contact part
- 11 insulating socket
- 12 housing

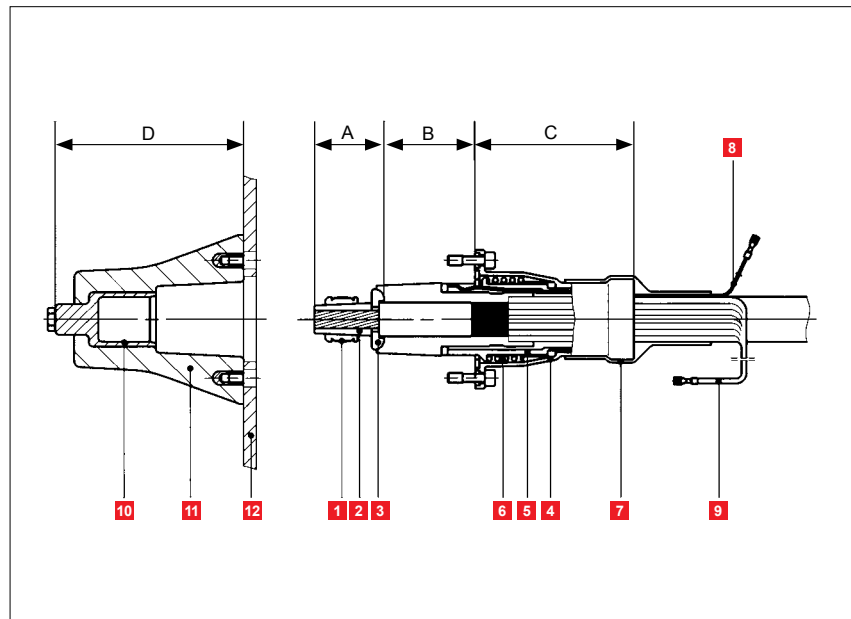

MV-CONNEX Multi-Contact Elbow Bushing up to 52 kV

Multi-contact elbow bushings are used instead of DIN-standard porcelain versions on the medium-voltage side of power transformers. They distribute the current over two or four cables, thus accommodating higher power loads using more manageable cable cross sections.

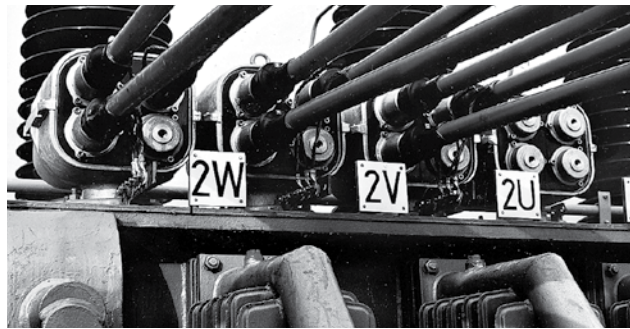

MV-CONNEX Surge Arrester up to 52 kV

CONNEX surge arresters are used to protect metal-enclosed switchgear fitted with cable terminations in accordance with EN 50180/EN 50181. The surge arresters are connected to the switchgear transformer and prevent the entry of excessively high surges. The surge arresters are particularly effective in limiting surges caused by reflected travelling waves and switching overvoltages.

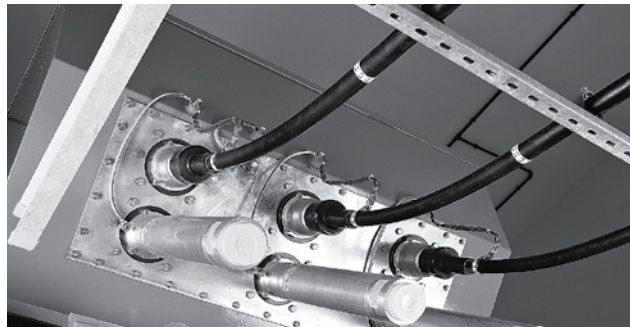

MV-CONNEX Busbar Connectors up to 42 kV

Busbar connectors facilitate the modular construction and on-site expansion of SF6 insulated switchgear, because the gas compartment does not have to be opened during installation. The range includes 24 kV to 42 kV versions.

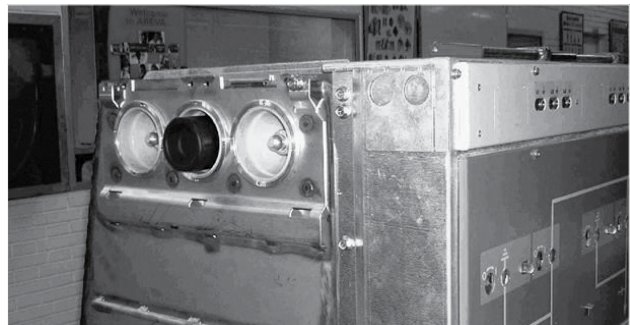

CMA-MV-CONNEX Motor Connector up to 13,8 kV

The CMA-MV-CONNEX motor connector allows the quick and easy connection of high-voltage motors, with the connection area being fully metal-enclosed and intrinsically safe. The system is easily installed in place of the motor connection box.

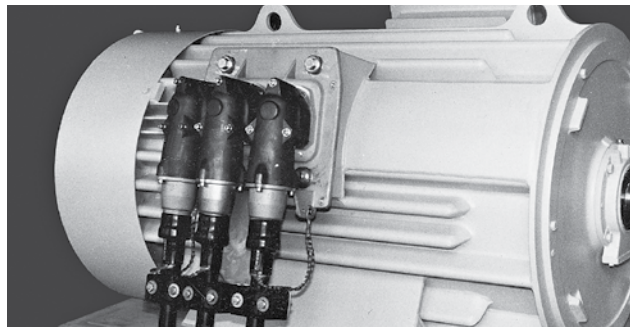

Voltage Detecting Systems

The integrated capacitive potential point makes it easy to check the connection for the absence of voltage. The PFISTERER range includes mobile and stationary continuous voltage indicators, as well as phase comparators and performance testing equipment.





MV-CONNEX Separable Connectors, Size 0 - 3-S Technical Data and Size Classification List

■ type tested in accordance to IEC 60 502-4:2005 / DIN VDE 0278-629-1:2006

- ¹⁾ If not required, the voltage tap must be earthed separately.
- ²⁾ The min. and max. cross sections can only be achieved by maintaining the min. or max. diameter across the conductors and the min. or max. diameter across the insulation.
- ³⁾ The entire diameter range is covered by various components.

Size	0			1			2			3			3-S						
Max. operating voltage	U_m	(kV)		24	36		42			42			52						
Rated voltage	U	(kV)		20	30		36			36			45						
Line-to-earth-voltage	U_0	(kV)		12	18		20,8			20,8			26						
Nominal current	I_n	(A)		250	630		800			1250			1250						
Conductor		RM	RE	RF	RM	RE	RF	RM	RE	RF	RM	RE	RF	RM	RE	RF			
Cross section (Guide value) ²⁾	Min.	(mm ²)		25	35	16	25	70	16	25	70	16	35	95	25	35	95	25	
	Max.	(mm ²)		70	70	50	240	240	185	400	325	240	800	1000	400	800	1000	400	
Diameter (Set value) ³⁾	Min.	(mm)		5,6	5,6	5,6	4,9	8,3	6,5	4,9	8,3	6,5	6,1	10,5	6,5	17,5	10,5	6,5	
	Max.	(mm)		11,9	11,9	11,9	20,1	20,1	18,3	24,1	22,0	20,6	36,0	36,0	26,8	36,0	36,0	26,8	
Voltage tap		without		with ¹⁾		with- out	with ^{1)/} without		without (XL)		with ^{1)/} without		without (XL)		with ^{1)/} without		without (XL)		
Diameter of insulation ³⁾ after removing the outer semi-conducting layer	Min.	(mm)		12,7		13,5	13,5		13,5	36,0		15,5		46,0		15,5		46,0	
	Max.	(mm)		23,5		31,5	36,0		36,0		44,0		46,0		55,0		46,0		55,0
Rated AC voltage	5 min.	(kV)		54	81		95			95			117						
Partial discharge level at $2 \times U_0$		(pC)		≤ 10		≤ 10		≤ 10			≤ 10			≤ 10					
Rated lightning impulse withstand voltage (BIL)		(kV)		125		170		200			200			250					
DC voltage test	15 min.	(kV)		72	108		125			125			156						
Rated short time current	1 s	(kA)		16	31,5		40			60			60						
	3 s	(kA)		-	16		25			40			40						
Rated impulse current		(kA)		40	125		125			150			150						

Form to determine MV-CONNEX Cable Connectors

Company: _____ **Name:** _____
Telephone: _____ **Date:** _____
E-mail: _____ **Signature:** _____
Cable manufacturer: _____ **Cable type:** _____

cable connector: Size 0 Size 1 Size 2 Size 3 / 3-S
Application: (Cable Connectors) indoor outdoor offshore (saltwater-proof) soil-resistant ATEX/IECEX
(only size 1 $U_m = 11$ kV)
ambient temperature, deepest temperature: down to - 25°C - 25°C to - 50°C (only without voltage tap)
Position of installation: vertical from above other
Capazitive voltage tap: yes no

Voltages: U_0 (phase-earth) _____ kV U_n (phase-phase) _____ kV U_m (max. operating voltage $2 \times U_0$) _____ kV
Cable design: single core cable three core cable

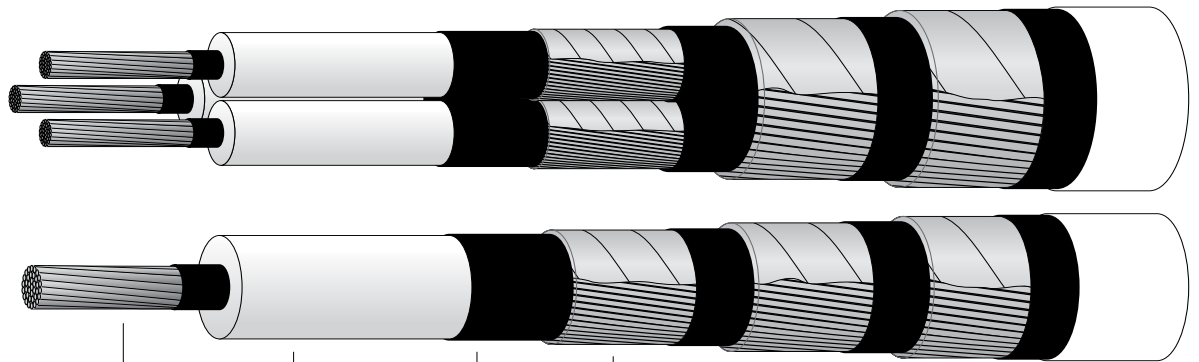





conductor insulation conducting layer cable screen 1. armouring 2. armouring outer jacket

Diameter (mm) _____

Cross Section (mm²) _____

Thickness (mm) _____

stranded circular RM <input type="checkbox"/> 	XLPE <input type="checkbox"/>	fully bonded <input type="checkbox"/>	Cu-wire <input type="checkbox"/>	Cu-wire <input type="checkbox"/>	Cu-wire <input type="checkbox"/>	PE <input type="checkbox"/>
stranded sector SM <input type="checkbox"/> 	EPR <input type="checkbox"/>	easy strip <input type="checkbox"/>	Cu-tape <input type="checkbox"/>	Cu-tape <input type="checkbox"/>	Cu-tape <input type="checkbox"/>	PVC <input type="checkbox"/>
solid circular RE <input type="checkbox"/> 		graphite <input type="checkbox"/>	Al-wire <input type="checkbox"/>	Al-wire <input type="checkbox"/>	Al-wire <input type="checkbox"/>	
solid sector SE <input type="checkbox"/> 		without semi-conducting layer <input type="checkbox"/>	Al-tape <input type="checkbox"/>	Al-tape <input type="checkbox"/>	Al-tape <input type="checkbox"/>	
superflexible stranded RF <input type="checkbox"/> 			Lead sheath <input type="checkbox"/>	steel-wire <input type="checkbox"/>	steel-wire <input type="checkbox"/>	
			Cu-corr. sheath <input type="checkbox"/>	steel-tape <input type="checkbox"/>	steel-tape <input type="checkbox"/>	
			Al-corr. sheath <input type="checkbox"/>	Lead sheath <input type="checkbox"/>	Lead sheath <input type="checkbox"/>	
			Fibre optic cable <input type="checkbox"/>	Cu-corr. sheath <input type="checkbox"/>	Cu-corr. sheath <input type="checkbox"/>	
			up to 3 earth braid <input type="checkbox"/>	Al-corr. sheath <input type="checkbox"/>	Al-corr. sheath <input type="checkbox"/>	
				Inner sheath <input type="checkbox"/>	Inner sheath <input type="checkbox"/>	
				Filling compound <input type="checkbox"/>	Filling compound <input type="checkbox"/>	
				Cu-foil <input type="checkbox"/>	Cu-foil <input type="checkbox"/>	
				Al-foil <input type="checkbox"/>	Al-foil <input type="checkbox"/>	
				Fibre optic cable <input type="checkbox"/>		

Remark: _____

CABLE CONNECTOR

CABLE DESIGN

2013-03



MV-CONNEX Separable Connectors, Size 0, $U_m = 24 \text{ kV}$, $I_N = 250 \text{ A}$

Standard article no.

- for DIN VDE cables
- for RM-conductor (stranded circular) of aluminium or copper
- for single core cable with copper wire shield without armouring
- with sealing system (bell flange seal and shrink tubing)
- for indoor and outdoor applications
- not soil-resistant and not offshore-proof
- Packaging unit: set with three separable connectors
- 3-core version on request (see page 17: product configurator)

No.	Max. operating voltage U_m (kV)	for cable cross section (mm ²)	for diameter over conductor (mm)	Insulation thickness (nominal value) (mm)	for diameter over XLPE insulation Ø (mm)
870 010 025	12	25	5.6 - 6.5	3.5	12.7 - 16.3
870 010 035	12	35	6.6 - 7.5	3.4	12.7 - 16.3
870 010 050	12	50	7.7 - 8.6	3.4	15.0 - 19.2
870 010 070	12	70	9.3 - 10.2	3.4	15.0 - 19.2
870 020 025	24	25	5.6 - 6.5	5.5	15.0 - 19.2
870 020 035	24	35	6.6 - 7.5	5.5	18.0 - 21.7
870 020 050	24	50	7.7 - 8.6	5.5	18.0 - 21.7
870 020 070	24	70	9.3 - 10.2	5.5	20.0 - 23.5

MV-CONNEX Separable Connectors, Size 1, $U_m = 36 \text{ kV}$, $I_N = 630 \text{ A}$

Standard article no.

- for DIN VDE cables
- for RM-conductor (stranded circular) of aluminium or copper
- for single core cable with copper wire shield without armouring
- with sealing system (bell flange seal and shrink tubing)
- for indoor and outdoor applications
- not soil-resistant and not offshore-proof
- offshore version on request (see page 17: product configurator)
- Packaging unit: set with three separable connectors
- 3-core version on request (see page 17: product configurator)

The picture shows MV-CONNEX separable connector without voltage tap



No.	No.	Max. operating voltage	for cable cross section	for diameter over conductor	Insulation thickness (nominal value)	for diameter over XLPE insulation
with voltage tap	without voltage tap	U_m (kV)	(mm ²)	(mm)	(mm)	Ø (mm)
850 110 035	870 110 035	12	35	6.0 - 7.3	3.4	13.5 - 17.5
850 110 050	870 110 050	12	50	7.5 - 8.8	3.4	13.5 - 17.5
850 110 070	870 110 070	12	70	9.3 - 10.6	3.4	16.0 - 19.5
850 110 095	870 110 095	12	95	10.8 - 12.1	3.4	18.0 - 21.5
850 110 120	870 110 120	12	120	12.3 - 13.6	3.4	18.0 - 21.5
850 110 150	870 110 150	12	150	13.8 - 15.1	3.4	20.0 - 23.5
850 110 185	870 110 185	12	185	15.3 - 16.6	3.4	22.0 - 25.5
850 110 240	870 110 240	12	240	17.8 - 19.1	3.4	25.0 - 28.5
850 120 035	870 120 035	24	35	6.0 - 7.3	5.5	18.0 - 21.5
850 120 050	870 120 050	24	50	7.5 - 8.8	5.5	18.0 - 21.5
850 120 070	870 120 070	24	70	9.3 - 10.6	5.5	20.0 - 23.5
850 120 095	870 120 095	24	95	10.8 - 12.1	5.5	22.0 - 25.5
850 120 120	870 120 120	24	120	12.3 - 13.6	5.5	23.5 - 27.0
850 120 150	870 120 150	24	150	13.8 - 15.1	5.5	25.0 - 28.5
850 120 185	870 120 185	24	185	15.3 - 16.6	5.5	26.5 - 30.0
850 120 240	870 120 240	24	240	17.8 - 19.1	5.5	28.0 - 31.5
850 130 050	870 130 050	36	50	7.5 - 8.8	8.0	23.5 - 27.0
850 130 070	870 130 070	36	70	9.3 - 10.6	8.0	25.0 - 28.5
850 130 095	870 130 095	36	95	10.8 - 12.1	8.0	26.5 - 30.0
850 130 120	870 130 120	36	120	12.3 - 13.6	8.0	28.0 - 31.5
-	870 130 150	36	150	13.8 - 15.1	8.0	30.0 - 33.5
-	870 130 185	36	185	15.3 - 16.6	8.0	31.0 - 34.5



MV-CONNEX Separable Connectors, Size 2, $U_m = 42 \text{ kV}, I_N = 800 \text{ A}$

Standard article no.

- for DIN VDE cables
- for RM-conductor (stranded circular) of aluminium or copper
- for single core cable with copper wire shield without armouring
- with sealing system (bell flange seal and shrink tubing)
- for indoor and outdoor applications
- not soil-resistant and not offshore-proof
- offshore version on request (see page 17: product configurator)
- Packaging unit: set with three separable connectors
- 3-core version on request (see page 17: product configurator)
- rotatable flange

The picture shows MV-CONNEX separable connector with voltage tap.

No.	No.	Max. operating voltage	for cable cross section	for diameter over conductor	Insulation thickness (nominal value)	for diameter over XLPE insulation	Rem.
with voltage tap	without voltage tap	U_m (kV)	(mm ²)	(mm)	(mm)	Ø (mm)	
850 210 050	870 210 050	12	50	7.5 - 8.8	3.4	13.5 - 17.5	
850 210 070	870 210 070	12	70	9.3 - 10.6	3.4	16.0 - 19.5	
850 210 095	870 210 095	12	95	10.8 - 12.1	3.4	18.0 - 21.5	
850 210 120	870 210 120	12	120	12.3 - 13.6	3.4	18.0 - 21.5	
850 210 150	870 210 150	12	150	13.8 - 15.1	3.4	20.0 - 23.5	
850 210 185	870 210 185	12	185	15.3 - 16.6	3.4	22.0 - 25.5	
850 210 240	870 210 240	12	240	17.8 - 19.1	3.4	25.0 - 28.5	
850 210 300	870 210 300	12	300	19.2 - 20.9	3.4	26.5 - 30.0	
850 220 050	870 220 050	24	50	7.5 - 8.8	5.5	18.0 - 21.5	
850 220 070	870 220 070	24	70	9.3 - 10.6	5.5	20.0 - 23.5	
850 220 095	870 220 095	24	95	10.8 - 12.1	5.5	22.0 - 25.5	
850 220 120	870 220 120	24	120	12.3 - 13.6	5.5	23.5 - 27.0	
850 220 150	870 220 150	24	150	13.8 - 15.1	5.5	25.0 - 28.5	
850 220 185	870 220 185	24	185	15.3 - 16.6	5.5	26.5 - 30.0	
850 220 240	870 220 240	24	240	17.8 - 19.1	5.5	28.0 - 31.5	
850 220 300	870 220 300	24	300	19.2 - 20.9	5.5	31.0 - 34.5	
850 230 035	870 230 035	36	35	6.0 - 7.3	8.0	16.0 - 19.5	
850 230 050	870 230 050	36	50	7.5 - 8.8	8.0	23.5 - 27.0	
850 230 070	870 230 070	36	70	9.3 - 10.6	8.0	25.0 - 28.5	
850 230 095	870 230 095	36	95	10.8 - 12.1	8.0	26.5 - 30.0	
850 230 120	870 230 120	36	120	12.3 - 13.6	8.0	28.0 - 31.5	
850 230 150	870 230 150	36	150	13.8 - 15.1	8.0	29.5 - 33.0	
850 230 185	870 230 185	36	185	15.3 - 16.6	8.0	31.0 - 34.5	
850 230 240	870 230 240	36	240	17.8 - 19.1	8.0	32.5 - 36.0	
-	870 235 300	36	300	19,7 - 21,4	8.0	36.0 - 38.5	(XL)

MV-CONNEX Separable Connectors, Size 3, $U_m = 42 \text{ kV}, I_N = 1250 \text{ A}$

Standard article no.

- for DIN VDE cables
- for RM-conductor (stranded circular) of aluminium or copper
- for single core cable with copper wire shield without armouring
- with sealing system (bell flange seal and shrink tubing)
- for indoor and outdoor applications
- not soil-resistant and not offshore-proof
- offshore version on request (see page 17: product configurator)
- Packaging unit: set with three separable connectors
- 3-core version on request (see page 17: product configurator)
- rotatable flange

The picture shows MV-CONNEX separable connector without voltage tap



No.	No.	Max. operating voltage	for cable cross section	for diameter over conductor	Insulation thickness (nominal value)	for diameter over XLPE insulation	Rem.
with voltage tap	without voltage tap	U_m (kV)	(mm ²)	(mm)	(mm)	Ø (mm)	
850 310 800	870 310 120	12	120	12.5 - 14.7	3.4	19.0 - 23.0	
850 310 150	870 310 150	12	150	13.5 - 15.7	3.4	19.0 - 23.0	
850 310 185	870 310 185	12	185	15.0 - 17.2	3.4	22.5 - 26.5	
850 310 240	870 310 240	12	240	17.5 - 19.7	3.4	24.5 - 28.5	
850 310 300	870 310 300	12	300	19.5 - 21.7	3.4	26.0 - 30.0	
850 310 400	870 310 400	12	400	22.6 - 24.8	3.4	30.0 - 34.0	
850 310 500	870 310 500	12	500	25.4 - 27.6	3.4	32.0 - 36.0	
850 310 630	870 310 630	12	630	28.9 - 31.1	3.4	36.0 - 39.5	
850 320 050	870 320 050	24	50	7.2 - 9.4	5.5	19.0 - 23.0	
850 320 070	870 320 070	24	70	9.0 - 11.2	5.5	19.0 - 23.0	
850 320 095	870 320 095	24	95	10.5 - 12.7	5.5	22.5 - 26.5	
850 320 120	870 320 120	24	120	12.5 - 14.7	5.5	22.5 - 26.5	
850 320 150	870 320 150	24	150	13.5 - 15.7	5.5	24.5 - 28.5	
850 320 185	870 320 185	24	185	15.0 - 17.2	5.5	26.0 - 30.0	
850 320 240	870 320 240	24	240	17.5 - 19.7	5.5	28.0 - 32.0	
850 320 300	870 320 300	24	300	19.5 - 21.7	5.5	30.0 - 34.0	
850 320 400	870 320 400	24	400	22.6 - 24.8	5.5	34.0 - 38.0	
850 320 500	870 320 500	24	500	25.4 - 27.6	5.5	36.0 - 39.5	
850 320 630	870 320 630	24	630	28.9 - 31.1	5.5	40.0 - 43.0	
850 330 050	870 330 050	36	50	7.2 - 9.4	8.0	22.5 - 26.5	
850 330 070	870 330 070	36	70	9.0 - 11.2	8.0	24.5 - 28.5	
850 330 095	870 330 095	36	95	10.5 - 12.7	8.0	26.0 - 30.0	
850 330 120	870 330 120	36	120	11.5 - 13.7	8.0	28.0 - 32.0	
850 330 150	870 330 150	36	150	13.5 - 15.7	8.0	30.0 - 34.0	
850 330 185	870 330 185	36	185	15.0 - 17.2	8.0	30.0 - 34.0	
850 330 240	870 330 240	36	240	17.5 - 19.7	8.0	34.0 - 38.0	
850 330 300	870 330 300	36	300	19.5 - 21.7	8.0	36.0 - 39.5	
850 330 400	870 330 400	36	400	22.6 - 24.8	8.0	38.0 - 41.0	
850 330 500	870 330 500	36	500	25.4 - 27.6	8.0	42.0 - 44.5	
-	870 335 630	36	630	28.9 - 31.1	8.0	44.5 - 47.0	(XL)
-	870 335 631	36	630	28,9 - 31,1	8,0	46.5 - 49.0	(XL)

Order Information

ATTENTION! Important information!

Special tools are required for the installation of the contact system of the MV-CONNEX separable connectors. Installation on round fine-wire conductors furthermore requires tools for round crimping sleeves on the RF conductor.

Only qualified personnel should work on or with the product. Qualified personnel includes employees who are able to evaluate the tasks assigned to them and to recognize possible dangers due to the technical training, skills, and experiences as well as knowledge of the relevant regulations. The qualified personnel can be trained and certified by PFISTERER or instructors authorized by PFISTERER on the installation of CONNEX separable connectors. The certificate is valid for 5 years.

For separable connectors with standard items, the selected operating voltage must match the maximum operating voltage of the DIN VDE cable because the operating voltage is correlated to the wall thickness of the insulating, based on which the matching insulating part assigned.

Due to the fact that the separable connector are intended for outdoor use in bushings installed „vertically from the above“, they must be installed with a sealing kit.

For separable connectors size 2 ^{*)}		Sealing kit for plug and Dummy plug	Sealing kit for Surge Arrester and Protection Cap
with standard item no. (from page 14)	1 set = 3 pieces	559 218 002	-
for replacement purposes	1 piece	559 218 012	559 218 111
configured with the product configurator and the selected application range "outdoor vertically from above" in the form defining MV-CONNEX separable connector		included	

*) in combination with sockets size 2 with item no. 827 104 005 or 827 104 205.

For cable terminations heads size 3 ^{*)}		Sealing kit for plug and Dummy plug	Sealing kit for Surge Arrester and Protection Cap
with standard item no. (from page 15)	1 set = 3 pieces	559 218 001	-
for replacement purposes	1 piece	559 218 011	559 218 112
configured with the product configurator and the selected application range "outdoor vertically from above" in the form defining MV-CONNEX separable connector		included	

*) in combination with socket size 3 with item no. 827 110 012 bzw. 827 110 212.

The characteristics of separable connectors for offshore and underground applications can only be selected via the product configurator. To do so, select „Offshore“ in the form defining MV-CONNEX separable connectors (see page 11).

Product Configurator

For cables that have not been produced to comply with DIN VDE, a product configurator is used to determine an individual article number for the required MV-CONNEX cable connectors size 0 - 3-S. To do this the Form for determine MV-CONNEX Separable Connectors, found on page 11, must be fully completed.

The individual article number consists of a base number and a variant number and contains all parts for connecting and earthing the individual cable.

MV-CONNEX Separable Connectors				1 set = 3 pieces	1 piece
Size	U _m (kV)	I _n (A)	max. Ø over isolation [mm]		
0	24	250	23,5	809 999 999 Var. XXXX	801 999 999 Var. XXXX
1	36	630	36,0	819 999 999 Var. XXXX	811 999 999 Var. XXXX
2	42	800	36,0	829 999 999 Var. XXXX	821 999 999 Var. XXXX
2 (XL)*	42	800	44,0	823 999 999 Var. XXXX	822 999 999 Var. XXXX
3/3-S	42/52	1250	46,0	839 999 999 Var. XXXX	831 999 999 Var. XXXX
3/3-S (XL)*	42/52	1250	55,0	833 999 999 Var. XXXX	832 999 999 Var. XXXX

* XL“ and „S“ are PFISTERER-specific designations. The separable cable connectors are compatible with sockets conforming to EN 50180/50181 in sizes 2 or 3.

Tools for Round-Pressing Aluminium Sleeves

Aluminium Carrying Case - Empty

for tools for round-pressing aluminium sleeves.

No.

305 767 001



Hydraulic tool head 850 bar

Hydraulic tool head 850 bar with oil-tight coupling plug for couple system for two-stage high pressure pump ZHP, electro hydraulic high pressure pump EHP and battery-operated hydraulic high pressure pump AHP with pump connection (coupling joint).

No.	Type	Power stroke (mm)	Nominal com- pression force (kN)	Weight (kg)
305 818 001	BIII	30	240	6.5



U-bow

Apart from the standard U-bow, another U-bow with round compression dies is available to allow copper and aluminium conductor cross sections greater than 300 mm² to be compressed with the compression head BIII.

Tool surface, burnished.

No.

300 570 570





1

Round Compression Dies

For round-pressing aluminum sleeves on fine-wire conductors of the flexible cable, the following high-pressure round compression dies are required:

No.	Compression die code No.	Outer diameter of the aluminium crimping sleeve Ø (mm)	for aluminium crimping sleeve
300 632 632	HR 11	13.0	558 003 001
			558 003 006
			558 003 015
			558 003 023
			558 003 031
300 632 635	HR 16	18.5	558 003 005
			558 003 007
			558 003 008
			558 003 010
			558 003 013
			558 003 017
300 632 637	HR 20	22.5	558 003 018
			558 003 012
			558 003 020
			558 003 009
300 632 639	HR 22	25.0	558 003 021
300 632 640	HR 25	28.5	558 003 022
			558 003 014
			558 003 016
300 642 001	HR 28	32.0	558 003 030
			558 003 011
			558 003 019
			558 003 027
300 641 001	HR 32	36.5	558 003 032
			558 003 024
			558 003 025
			558 003 026



Two-stage high pressure pump

The high-pressure unit is mounted horizontally on a galvanised U-frame. The valve body is made of aluminium alloy. Therefore the pump is very light. The high-pressure hose is fitted with an oil-tight coupling socket for connecting the compression head. The pump operates with rapid thrust until the compression starts, thus requiring fewer power strokes. An excess pressure valve protects the compression tool against overload.

No.	Operating pressure (bar)	Hose length (mm)	Hydraulic oil volume (cm ³)
305 799 002	850	3000	600

Assembly Accessories

Carrying Case - empty -

for tools to assembly CONNEX separable connector



No.
305 768 001

Assembly Tools

for CONNEX separable connectors, size 1 - 3/3-S, complete in a case.

No.	Size	consisting of
305 768 003	3/3-S + 3/3-S (XL)	305 768 001
		827 017 002
		305 675 013
		559 214 003
		563 376 002
		827 165 001
		827 167 001
		827 166 001
		305 051 051
		305 063 063
305 768 004	1 + 2 + 2 (XL) + 3/3-S + 3/3-S (XL)	305 768 001
		827 017 002
		305 675 013
		305 675 001
		305 675 002
		559 214 001
		559 214 002
		559 214 003
		827 165 001
		563 376 002
		827 167 001
		827 166 001
		305 051 051
		305 063 063
305 768 005	2 + 2 (XL)	305 768 001
		827 017 002
		305 675 002
		559 214 002
		563 376 002
		305 051 051
305 768 006	2 + 2 (XL) + 3/3-S + 3/3-S (XL)	305 768 001
		827 017 002
		305 675 013
		305 675 002
		559 214 002
		559 214 003
		563 376 002
		827 165 001
		827 167 001
		827 166 001
		305 051 051
305 063 063		
305 768 007	1	305 768 001
		827 017 002
		305 675 001
		559 214 001
		563 376 002
		305 051 051
		305 063 063



Hydraulic Hand-Operated Compression Tool

Basic Tool for sizes 1, 2 and 3 without compression head.

No.
827 017 002





Compression Head

including pull-off die for hand-operated compression tool.

No.	Size
305 675 001	1
305 675 002	2
305 675 013	3



Impact Device

made of plastic. For the pre-assembly of the separable connector contact.

No.	Size
559 214 001	1
559 214 002	2
559 214 003	3



T-Handle Hex Wrench SW 6

for tightening the screws of separable connectors sizes 0 - 3.

No.
563 376 002



Assembly Lever

for pressing and releasing the CONNEX separable connector size 3.

No.
827 167 001

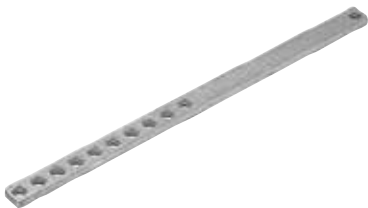

Hole Bar

for suspending the assembly lever (only for Size 3).

No.
827 166 001



Chain

for suspending the assembly lever and hole bar (only for Size 3).

No.
827 165 001

Unplug Rod for Assembly Level

for MV-CONNEX separable connectors, size 1,2, 3.

No.

827 229 001



Assembly Clamp

Assembly clamp for holding the cable during heat-shrinking and for releasing the CONNEX separable connector.

No.

827 153 001



Cable Stripper

for PE/XLPE insulation. Longitudinal and radial cutting with adjustable depth stop with a diameter of 15 - 45 mm.

No.

305 051 051



Spare Blade for Cable Stripper

No.

305 063 063



Open hand-operated compression tool Primat 06-T

Gripper for CONNEX cable connecting part size 0.

Hexagon pressing tool for hand-held jointing clamp PRIMAT O6 T, classification number 18 Al for Al and Cu conductors 25 - 70 mm².

No. 300 455 458

Important!

The crimp sleeve for the CONNEX cable connecting part size 0 should generally be pressed for Al and Cu cables of 25 - 70 mm² using the pressing tool KZ 18 Al.

No.

303 871 002





Hexagonal Compression Dies

For copper and steel crimp connections. Suitable for mechanical compression tool MPZ O6, battery-operated hydraulic compression tool HAP O6, hydraulic die head HWK O6, hydraulic compression tool EPC 50-A and battery-operated hydraulic compression tool REC-60 E.

No.	Code number	width b (mm)
300 438 441	8	32
300 438 443	10	32
300 438 445	12	32
300 438 447	14	32
300 438 448	16	32
300 438 449	18	32
300 438 451	20	32
300 438 452	22	32
300 438 453	25	32



MV cable peeling tools for cable preparation - incl. case

For removal of the outer sheath (diameter range: 15 - 55 mm), peeling of the semi-conducting layer (diameter range: 15 - 49 mm) and chamfering of the conductor insulation.

- 827 951 004: outer jacket cutter for diameter over insulation 15 - 49 mm
- 827 951 005: peeling tool for fully bonded semi-conducting layer, diameter 15 - 55 mm
- 827 951 002: spare blade for outer jacket cutter 827 951 004
- 827 951 003: spare blade for peeling tool 827 951 005
- 827 952 001: Edge cutter for up to 60 mm diameter across insulation

MV cable stripper - without case

For removal of the outer sheath (diameter range: 15 - 55 mm), peeling of the semi-conducting layer (diameter range: 15 - 49 mm) and chamfering of the conductor insulation.

- 827 951 006: Screen stripper for 34 - 60 mm diameter
- 827 951 007: Spare blade for screen stripper 827 951 006
- 827 951 008: Set of stop rings for 827 951 006



Plug-In Type Assembly Socket

for the pre-assembly of CONNEX separable connectors (e.g. in the workshop).

No.	Size
827 174 003	0
827 174 001	1
827 174 002	2
827 174 004	3



Blind Cap

protection against electric-shock hazard for live CONNEX separable connector.

No.	Size	Rated power frequency withstand voltage		Rated lightning impulse withstand voltage (BIL) (kV)
		1 min (kV)	1h (kV)	
827 130 001	0	54	30	125
827 131 001	1	81	45	170
827 132 001	2	81	52	170
827 133 001	3	95	65	200

Dummy Plug

- for sealing and voltage-proof closing of CONNEX sockets
- suitable for outdoor use or offshore-/soil-proof

No.	Size	Max. operating voltage U_m (kV)	Use 1	Weight (kg)
827 150 005	0	24	for outdoor use	0.5
827 150 002	1	36	for outdoor use	0.6
827 150 003	2	42	for outdoor use	0.6
827 150 004	3	52	for outdoor use	1
827 150 203	2	42	offshore- and soil-proof	1
827 150 304	3	52	offshore- and soil-proof	1.1



Dummy Plug with Voltage Tap

Dummy cable plug with voltage tap

- for voltage-proof sealing of CONNEX sockets
- suitable for outdoor use
- voltage tap for connection to continuous voltage indicator

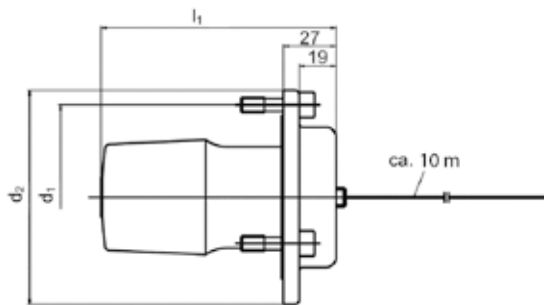

No.	Size	Max. operating voltage U_m (kV)	d_1 (mm)	d_2 (mm)	C_1 (pF)	C_2 (pF)	Weight (kg)
827 150 120	3	52	130	147	5	1035	1.8

Protection Cap

- not voltage proof

For protecting withdrawn CONNEX separable connectors against damage and dirt.

No.	Size	Material
546 133 001	0, 1	Plastic
827 134 004	0	Metal
827 134 001	1	Metal
827 134 002	2	Metal
827 134 003	3	Metal



Protective cover, not voltage-proof

for socket.

No.	Size
827 220 201	1
827 220 202	2
827 220 203	3





Roll Springs

Earthing accessories for cables with metallic band shield and/or armour. These are assigned using the cable data from the product configurator.

No.	Diameter roll springs Ø (mm)	Width b (mm)
546 078 009	14 - 22	16
546 078 002	25 - 40	13
546 078 003	30 - 39	25
546 078 004	40 - 60	25
546 078 007	50 - 75	30
546 078 010	75 - 100	30



Clamping collar acc. DIN 3017, Material V2A, W5

Earthing accessories for cables with metallic band shield and/or armour. These are assigned using the cable data from the product configurator.

No.	Clamping Range (mm)	Width b (mm)
620 866 001	20 - 32	10
617 825 007	32 - 50	10
617 825 001	40 - 60	10
617 825 002	50 - 70	10
617 825 003	60 - 80	10
617 825 005	80 - 100	10
617 825 006	100 - 120	10
617 825 008	120 - 140	10
617 825 009	140 - 160	10

MV-CONNEX Special Grease

Is included for use when first fitting the separable connecting part. If the separable connector needs to be re-fitted, the MV-CONNEX special grease must be ordered separately.

No.	Type	Weight (g)	Temperature range (°C)
558 228 008	Bag	10	down to -25 °C
558 228 007	Can	500	down to -25 °C
002 854 003	Bag	8	down to -45° C



Shrink Tube

Included in delivery for separable connectors with a sealing system.

No.	Heat shrink area d (mm)	Length l (mm)	Size
619 528 528	70 - 20	125	0
619 528 003	90 / 25	150	1, 2
619 528 001	130 / 39	225	3
023 998 002	115 / 34	425	3 (XL)
619 528 008	90 / 25	300	2 (XL)



Sealing Tape

Included in delivery for separable connectors with a sealing system.

No.	Width b (mm)	Thickness d (mm)	Length l (mm)
545 036 002	25.4	1.6	300





Copper Mesh Hose

No.	Width b (mm)
001 743 005	75
001 743 007	100
001 743 017	45



Cotton-Insulating Tape

for bundling energy cables.

No.
001 743 016



Dry graphite (5ml)

for adding an additional semi-conducting layer, e.g. for removable or thick conductive semi-conducting layer.

No.
003 010 011



Cable Breakout

is classified under three-core cables by the product configurator.

No.	Heat shrink area d (mm)	Heat shrink area D (mm)	Length l (mm)
020 839 025	31 / 16	80 / 36	195
020 839 026	41 / 20	110 / 48	230
020 839 027	53 / 27	140 / 62	230
020 839 023	60 / 30	170 / 60	230

Shrink Tube

is classified under three-core cables by the product configurator.
 *) Length 5000 mm for 3 cores

No.	Heat shrink area d (mm)	Length l (mm)	
023 998 010	51 / 16	5000	*)
023 998 011	68 / 22	5000	*)



Conductive Crepe Paper

is classified by the product configurator as a buffer between the extruded cable shielding and the copper mesh if common shielding.

No.	Length l (mm)	Width b (mm)
002 756 010	5000	50

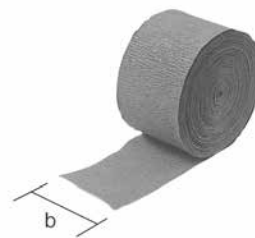

Copper Mesh Tape

is classified by the product configurator using the cable data if cables with band shield and/or band armour.

No.	Width b (mm)	Thickness d (mm)	Length l (mm)	Cross section (mm ²)
001 743 009	22	2.5	1000	25
001 743 008	30	2.5	1000	35
001 743 010	22	2.5	1500	25
001 743 015	30	2.5	1500	35



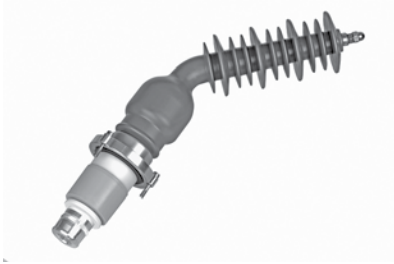

CONNEX Test and Adapter Connector

To fulfill multiple usage requirements, the component is designed with 45° angle.

They are used as transitional connecting parts when transformers that are equipped with CONNEX interface are connected to blank (overhead) lines.

They are also used as CONNEX test connecting parts for electrical testing of equipment that is equipped with CONNEX interface.

No.	Size	Thread	Max. operating voltage	Nominal current	Rated power frequency withstand voltage	Rated lightning impulse withstand voltage (BIL)
			U_m (kV)	I_N (A)	1 min (kV)	(kV)
827 186 210	0	M12	24	250	54	125
827 186 211	1	M12	36	630	81	170
827 186 212	2	M12	42	800	95	200
827 186 213	3	M12	42	800	95	200

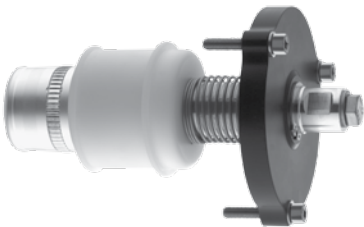

Current-Testing Connectors

This connector permits to carry out current tests on switchgears, transformers, transducers etc. fitted with CONNEX interface. Size 2 and 3 are offshore proof.

For the electrical and mechanical connection, the connector is inserted into a CONNEX socket of equal size and bolted. The test lead is connected to the terminal stud with a screw.

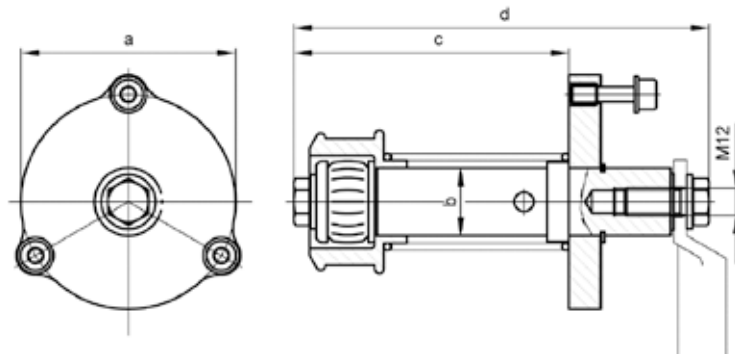

No.	Size	Nominal current	Test current	Rated short-time withstand current	Rated short-time withstand current	Max. testing voltage	a	b	c	d	Application
		I_N (A)	max. 4min./A	1 s (kA)	3 s (kA)	U_m (kV)					
827 181 010	0	250	750	16	-	2	88	30	122	184	outdoor-proof
827 181 011	1	630	2000	31.5	18	2	95	30	122	184	outdoor-proof
827 181 012	2	800	2500	40	25	2	102	30	122	184	offshore-proof
827 181 013	3	1250	3150	50	40	2	130	35	170	238	offshore-proof

Cable-Testing Socket

to be used during carrying out start-up tests on cables with MV-CONNEX separable connectors.

Caution:

The cable test socket is not touchproof. After testing, the test socket must be earthed and short-circuited. The cable test socket is not suitable for partial discharge measuring.



No.	Size	Rated DC With-stand Voltage		Weight (kg)
		1h (kV)	15 min. (kV)	
827 125 001	1	45	45	4.1
827 125 002	2	52	52	4
827 125 003	3	65	65	9.3

MV-CONNEX - Test lead and connection cable

The flexible test cables are used for electrical testing of operating equipment equipped with CONNEX sockets.

They are suitable for voltage and partial discharge testing on transformers and gas-insulated switchgears.

CONNEX separable cable connector is fitted to both ends of connecting cables.

A choice of flexible cables is available, to which the following MV-CONNEX separable cable connectors, outdoor terminations or end caps (not voltage-proof) can be fitted:

Trailing cable (N)TMCW0EU 26/45 (52) kV	MV-CONNEX cable connector Size	
50 mm ² (RF)	1, 2, 3, 3-S	Outdoor Termination or endcap (not voltage-proof)
95 mm ² (RF)	1, 2, 3, 3-S	
240 mm ² (RF)	2, 3, 3-S	
400 mm ² (RF)	3, 3-S	

A product configurator is used to configure customer-specific versions. Please refer to the form on page 31.

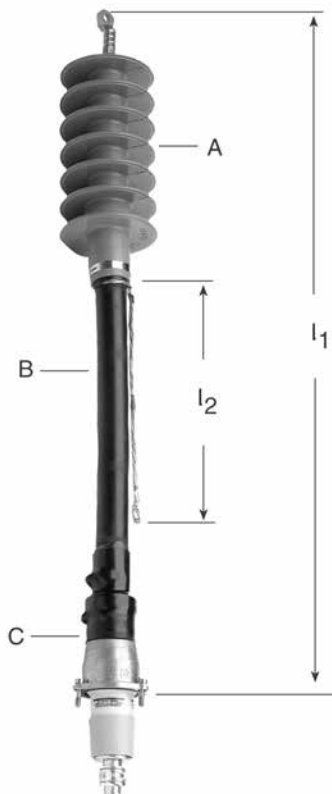

Test lead

The flexible test cables are used for electrical testing of operating equipment equipped with CONNEX sockets.

Also used for voltage and partial discharge testing on transformers and gas-insulated switchgears.

Standard article no.

- A = outdoor termination
- B = flexible cable
- C = CONNEX separable connector
- l_1 = length of the test cable
- l_2 = length of the screen wire

No.	Size	Max. operating voltage	Rated power frequency withstand voltage		Rated lightning impulse withstand voltage (BIL)	Cable cross section (mm ²)	Nominal current in the air at 30° C (A)	l_1 (m)	l_2 (mm)
			U_m (kV)	1 min (kV)					
810 105 110	1	36	70	54	170	95	440	1	300
810 105 113	1	36	70	54	170	95	440	2	300
810 105 210	2	42	95	63	200	95	440	1	300
810 105 212	2	42	95	63	200	95	440	3	300
810 105 213	2	42	95	63	200	95	440	2	300
810 105 222	2	42	95	63	200	95	440	1,5	300
810 105 310	3	42	95	63	200	95	440	1	300
810 105 319	3	42	95	63	200	95	440	1,6	300
810 105 323	3	42	95	63	200	95	440	2	300
810 105 329	3	42	95	63	200	95	440	3	300
810 105 352	3-S	52	117	78	250	95	440	1,9	300
810 105 391	3-S	52	117	78	250	400	980	2,1	300

Form to determine MV test lead and connecting cable

Company: _____	Name: _____
Telephone: _____	Date: _____
E-Mail: _____	Signature: _____

Application: Indoor / Outdoor Offshore (saltwater-proof/soil-resistant)

Max. operating voltage (BIL): up to 36 kV up to 42 kV up to 52 kV

Cable cross section: 50 mm² RF/52 kV 95 mm² RF/52 kV 240 mm² RF/52 kV (not for Size 1)
400 mm² RF/52 kV (not for Size 1, 2)

Length of test and connecting cable: L = _____ m (0,1 m Stufung)

Dielectric routine test AC + PD 100 % 10 % (one from min. 10 Stk.) None (with end-cap)

*** Phase description:** L1 L2 L3 N-Conductor None

Side A:	Side B:
CONNEX Size 1 (up to 36 kV) <input type="checkbox"/> CONNEX Size 2 (up to 42 kV) <input type="checkbox"/> CONNEX Size 3 (up to 42 kV) <input type="checkbox"/> CONNEX Size 3-S (up to 52 kV) <input type="checkbox"/> Outdoor termination (up to 42 kV) <input type="checkbox"/> Outdoor termination ESF (up to 52 kV) <input type="checkbox"/> End-cap (not voltage proof) <input type="checkbox"/>	CONNEX Size 1 (up to 36 kV) <input type="checkbox"/> CONNEX Size 2 (up to 42 kV) <input type="checkbox"/> CONNEX Size 3 (up to 42 kV) <input type="checkbox"/> CONNEX Size 3-S (up to 52 kV) <input type="checkbox"/> Outdoor termination (up to 42 kV) <input type="checkbox"/> Outdoor termination ESF (up to 52 kV) <input type="checkbox"/> End-cap (not voltage proof) <input type="checkbox"/>

Cable shield A:	Cable shield B:
Connected at bell flange <input type="checkbox"/> Length cable shield LA = _____ m <input type="checkbox"/>	Connected at bell flange <input type="checkbox"/> Length cable shield LB = _____ m <input type="checkbox"/>

Capacitive voltage tap (by CONNEX):	Capacitive voltage tap (by CONNEX):
yes <input type="checkbox"/> no <input type="checkbox"/>	yes <input type="checkbox"/> no <input type="checkbox"/>

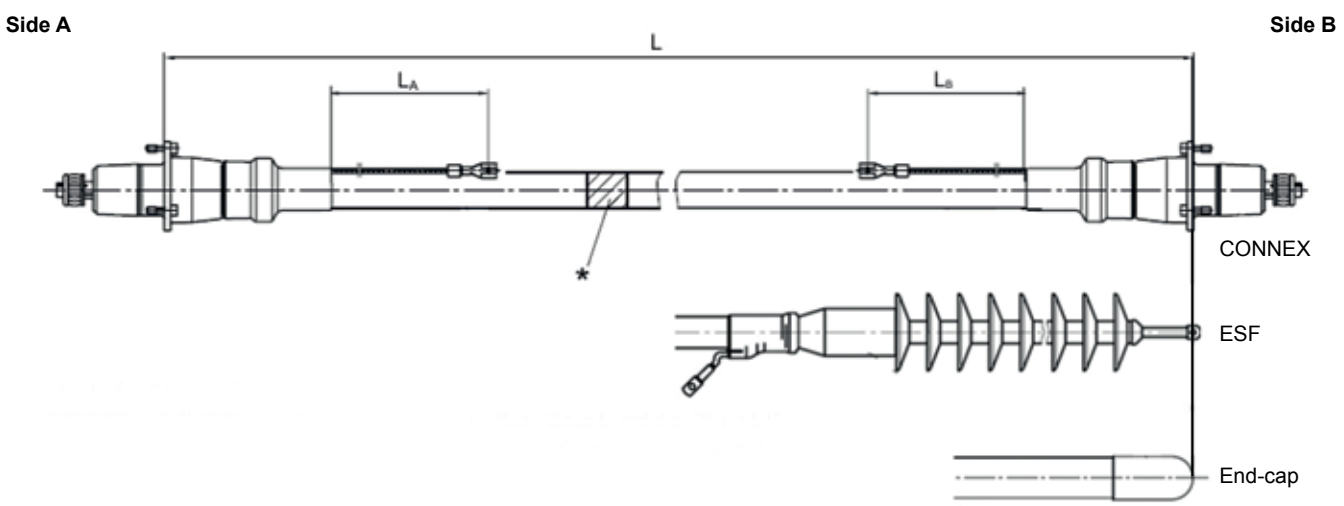



1 MV-CONNEX Transformer Sockets, straight

For local grid transformers, the transformer connecting pieces are fitted instead of the DIN porcelain bushings on the medium voltage side.

The insulation piece that extends into the transformer (dimensions l_1 and l_2) is available in different lengths in order to accommodate the type of transformer. The cables are connected using metal-encapsulated CONNEX separable connectors. On the 0.4 kV side there are corresponding insulating caps which provide total protection against contact.

Note:

For an example of application, see picture overview of local grid transformers. Not offshore qualified

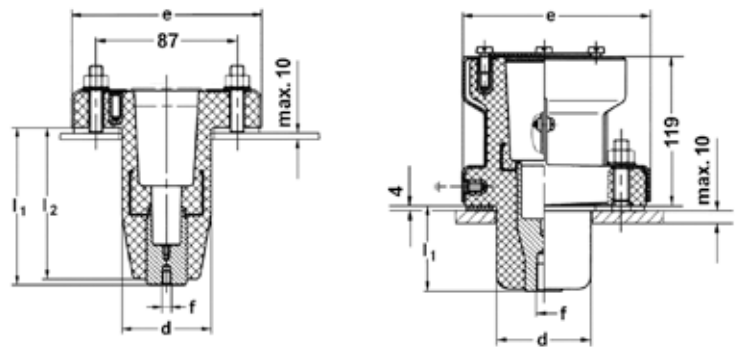

No.	Size	Max. operating voltage	Nominal current	Threaded connection	Weight (kg)	l_1 (mm)	d (mm)	e (mm)	
		U_m (kV)	I_N (A)	f					
827 115 004	0	24	250	M8 x 12	2.1	137	77	127	1
827 158 001	0	24	250	M12 x 22	3.4	68	75	130	2
827 159 001	1	24	630	M12 x 22	3.3	68	75	130	2



1 MV-CONNEX Elbow Adapters

The metal-encapsulated CONNEX elbow adapter is a component which can be used to convert straight CONNEX sockets into CONNEX elbow bushings. The system offers a connection that is angled by 90°. One side is designed as a CONNEX separable connector size 0 or 1, the other side as a CONNEX sockets of the same size. The grounded metal housing provides total protection against contact.

Note:

For an example of application, see picture overview of local grid transformers. Not offshore qualified

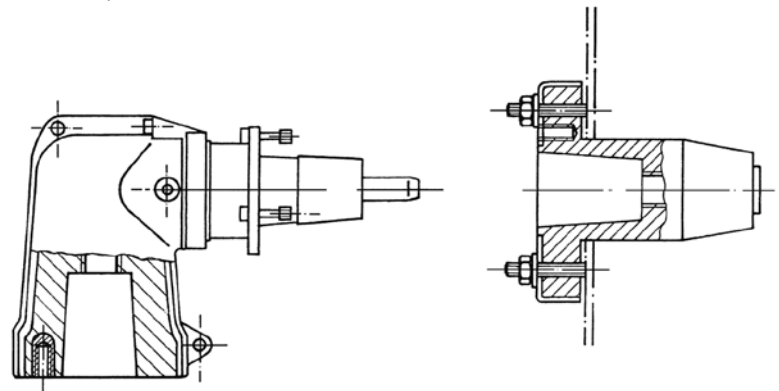

No.	Size	Max. operating voltage	Nominal current	Weight (kg)	
		U_m (kV)	I_N (A)		
827 176 001	0	24	250	4.3	1
827 180 001	1	24	630	5.4	2

MV-CONNEX Transformer Elbow Bushings

When installed, elbow bushings can be swiveled by 260°. The grounded metal housing provides absolute protection against electric-shock hazard. Fastening in accordance with DIN 42538 flange A, flange thickness of the transformer cover max. 10 mm.

Compression Sleeves: See page 34

Note: Not offshore qualified

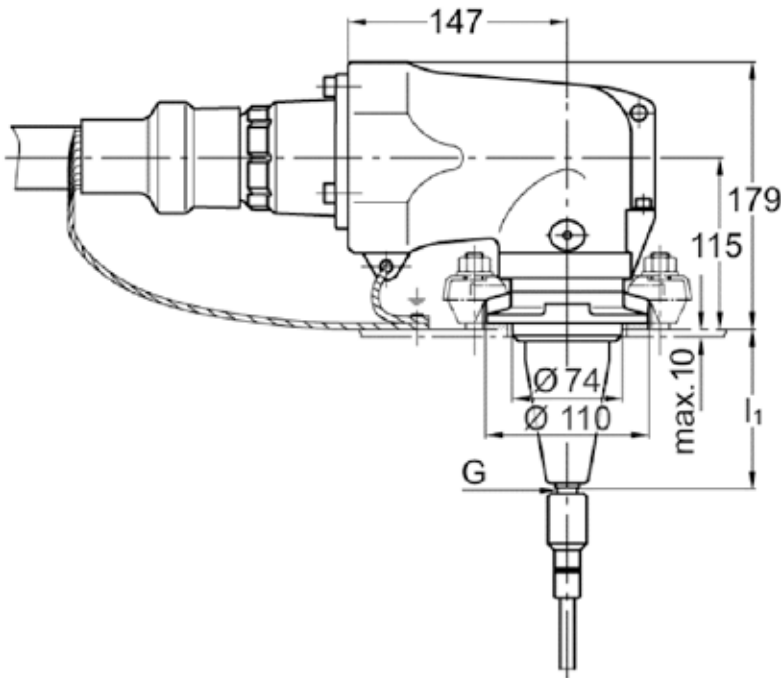

No.	Size	Max. operating voltage		Nominal current	Thread	Weight	I ₁
		U _m (kV)	I _N (A)				
827 107 064	0	24	250	M10	4.4	64	
827 107 107	0	24	250	M10	4.5	107	
827 107 168	0	24	250	M10	4.8	168	
827 117 064	1	36	630	M16	4.8	64	
827 117 107	1	36	630	M16	5	107	
827 117 168	1	36	630	M16	5.2	168	

Fixing set

for MV-CONNEX Elbow Bushing size 0 and 1. Comprises a flange ring, flat gasket, spring washers and hexagon nuts.

No.

827 190 017





1 Compression Sleeves

Only these compression sleeves are approved for connection of MV-CONNEX transformers elbow bushings size 0 and 1. For use with hexagonal compression dies.

2

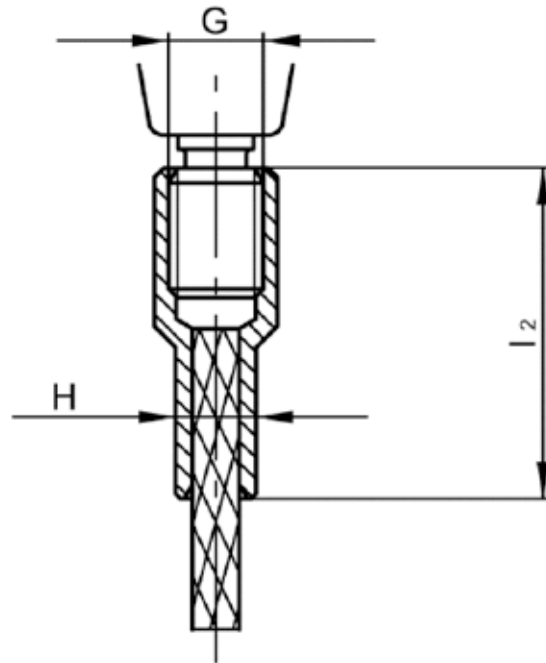

No.	for size	Cross section Cu strand wire (mm ²)	Diameter Cu strand wire according to DIN 46438 Ø (mm)	Diameter Cu strand wire according to DIN 60228 Ø (mm)	Pressing tool for		l ₂ (mm)	
					thread G	Cu strand H		
560 320 001	0	10	5.0	4,5 - 5,0	KZ 14	KZ 8	35	1
560 320 007	0	35	10.0	8,6 - 9,2	KZ 16	KZ 14	42	1
560 320 005	0	70	14.2	12,6 - 13,1	KZ 16	KZ 18	70	1
560 320 002	1	10	5.0	4,5 - 5,0	KZ 20	KZ 8	38	2
560 320 003	1	35	10.0	8,6 - 9,2	KZ 20	KZ 14	42	2
560 320 004	1	50	12.0	10,0 - 11,0	KZ 20	KZ 16	42	2
560 320 006	1	120	19.5	(16,2 - 17,0) ^{*)}	KZ 22	KZ 25	70	2
560 320 006	1	150	-	18,0 - 19,0	KZ 22	KZ 25	70	2

*) The diameters of the CU-stranded wires are to be re-crimped with the next smaller tool code (KZ 25 + KZ 22)

Picture overview of local grid transformers

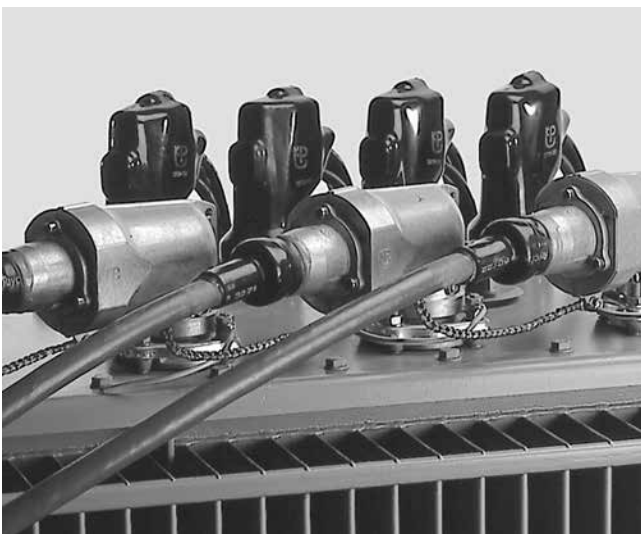
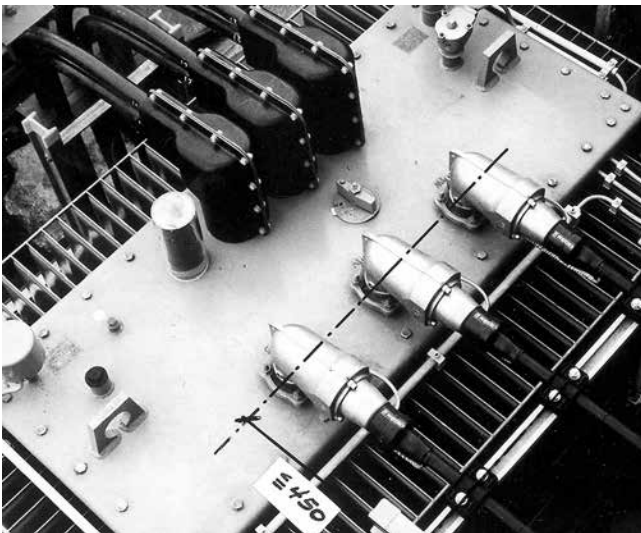
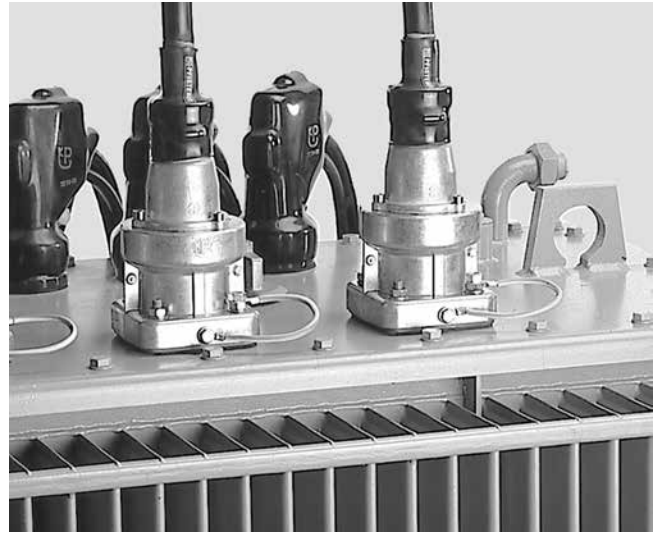
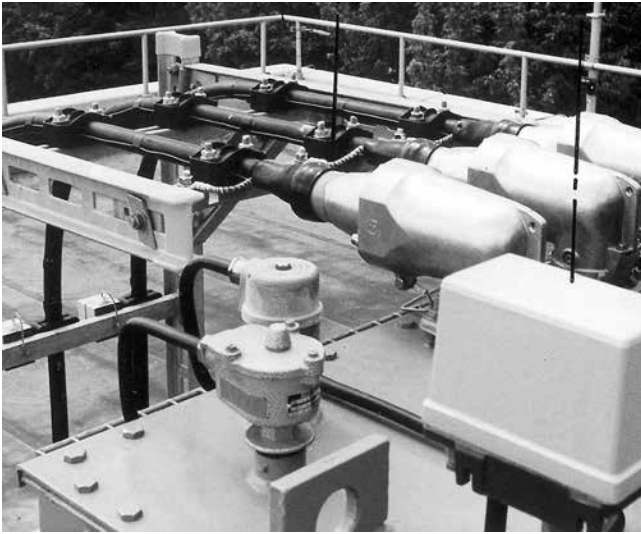



MV-CONNEX Multi-Contact Elbow Bushings

The multiple elbow bushings are fitted instead of the DIN porcelain bushings on the medium voltage side of the power transformer.

The multiple elbow bushings consist of an insulation body that is integrated in a metal housing is connected with a maximum of 2 or 4 cables using CONNEX cable connectors sizes 2 or 3.

The earthed metal housing provide total protection against contact and is suitable for offshore applications.

Unassigned sockets must be closed using dummy plugs such that they are voltage-proof.

External environmental influences, such as small animals and birds, cannot cause short circuits. Plug-in enclosed surge arresters can be fitted instead of a CONNEX cable connectors. The electrical connections in the transformer can be in the form of either clamps or plugs.

For power transformers suitable for fastening in accordance with DIN 42538, resistant to outside air.

Order connectors separately.

Cold shock tests in accordance with VDE 0441.

Caution:

The CONNEX dummy plugs are not provided and must be ordered separately.

MV-CONNEX Multi-Contact Elbow Bushings

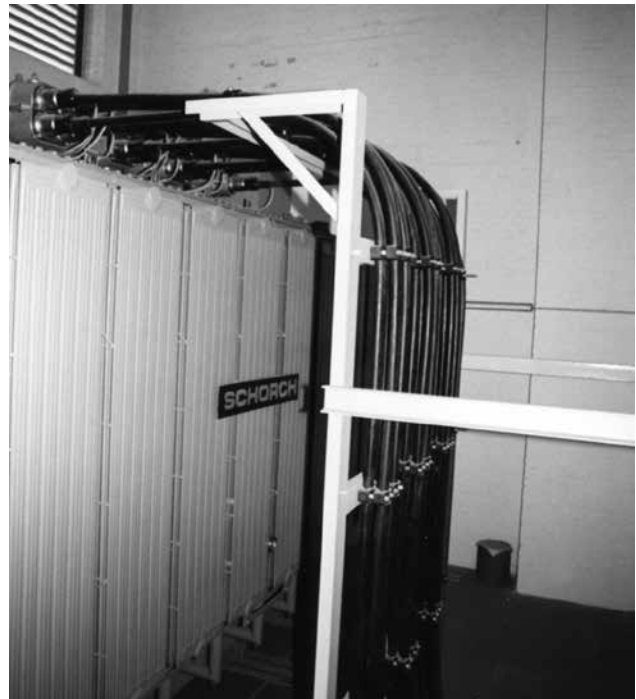
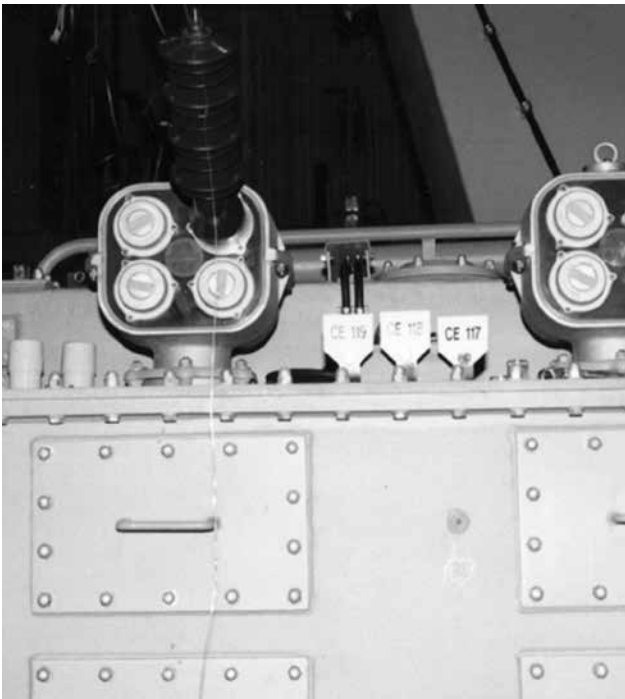



MV-CONNEX Double-Contact Elbow Bushings, up to 52 kV

For plug-in and clamping type construction respectively.
With aluminium housing.

- A** Plug-in type connecting part
- B** Clamping type connecting part (supplied by the transformer manufacturer)

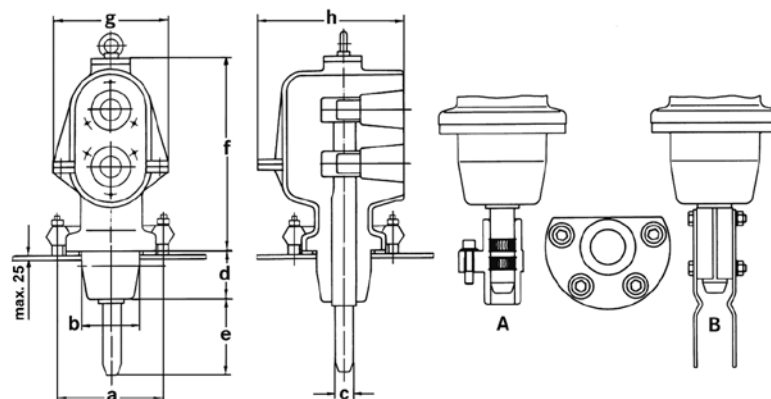

No.	Size	Max. operating voltage	max. rated current with plugged connection in transformer - type A	max. rated current with clamped connection in transformer - type B	dimensions						cone	
					a	b	c	d	e	f		g
		U_m (kV)	max. I_N (A)	max. I_N (A)	(mm)	(mm)	(mm)	(mm)	(mm)	(mm)	(mm)	
827 661 005	2	36	1250	1250	180	110	30	125	90	388	215	slim
827 661 006	2	36	1600	1600	200	135	35	125	125	388	215	standard
827 661 007	2	36	1600	1600	200	135	35	300	125	388	215	long ¹⁾
827 661 002	2	42	1250	1250	180	110	30	125	90	388	215	slim
827 661 001	2	42	1600	1600	200	135	35	125	125	388	215	standard
827 661 004	2	42	1600	1600	200	135	35	300	125	388	215	long ¹⁾
827 660 002	3	36	2200	2500	200	135	35	125	125	451	246	standard
827 660 007	3	36	2200	2500	200	135	35	300	125	451	246	long ¹⁾
827 660 001	3	42	2200	2500	200	135	35	125	125	451	246	standard
827 660 003	3	42	2200	2500	200	135	35	300	125	451	246	long ¹⁾
827 660 004	3	52	2200	2500	200	135	35	125	125	451	246	standard
827 660 006	3	52	2200	2500	200	135	35	300	125	451	246	long ¹⁾

¹⁾ For current transformers for measuring purposes

Plug-in Type Connecting Part (A)

No.	for CONNEX 2x-elbow connecting parts	for CONNEX 4x-elbow connecting parts	for connection	Weight	a
			bolt diameter Ø (mm)	(kg)	(mm)
827 128 710	827 661 002	827 124 715	30	2.5	180
	827 661 005	827 124 716			
827 128 730	827 660 001	827 124 723	35	2.8	200
	827 660 002	827 124 727			
	827 660 003	827 124 823			
	827 660 004	827 124 827			
	827 660 006	827 146 335			
	827 660 007	827 146 336			
	827 661 001	827 146 337			
	827 661 004	827 146 835			
	827 661 006	827 146 836			
	827 661 007	827 146 837			





1

Fixing set

For safe fixing and sealing of MV-CONNEX Elbow Bushings at transformers. Comprises a flange ring, flat gasket, spring washers and hexagon nuts. According to DIN 42538.

2

No.	for CONNEX 2x-elbow connecting parts	for CONNEX 4x-elbow connecting parts	a		
			(mm)		
827 190 016	827 661 002	827 124 715	180	-	1
	827 661 005	827 124 716			
827 190 015	827 660 001	827 124 723	200	-	1
	827 660 002	827 146 335			
	827 660 003	827 124 727			
	827 660 004	827 124 823			
	827 660 006	827 124 827			
	827 660 007	827 146 336			
	827 661 001	827 146 337			
	827 661 004	827 146 835			
	827 661 006	827 146 836			
	827 661 007	827 146 837			
827 190 116	827 661 002	827 124 715	180	offshore-proof	2
	827 661 005	827 124 716			
827 190 115	827 660 001	827 124 723	200	offshore-proof	2
	827 660 002	827 124 727			
	827 660 003	827 124 823			
	827 660 004	827 124 827			
	827 660 006	827 146 335			
	827 660 007	827 146 336			
	827 661 001	827 146 337			
	827 661 004	827 146 835			
	827 661 006	827 146 836			
	827 661 007	827 146 837			

Power Transformers, on the low-voltage side with multi-contact elbow bushings up to 52 kV

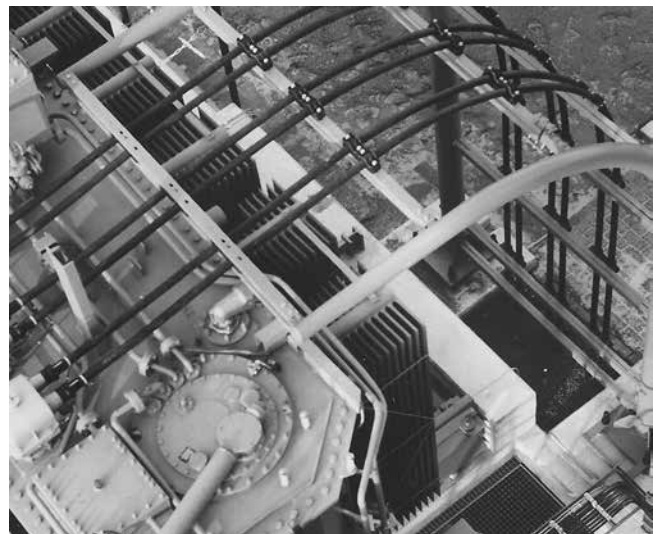

MV-CONNEX Transformer Bushings

MV-CONNEX Transformer Bushings

Power Transformers, on the low-voltage side with multi-contact elbow bushings up to 52 kV

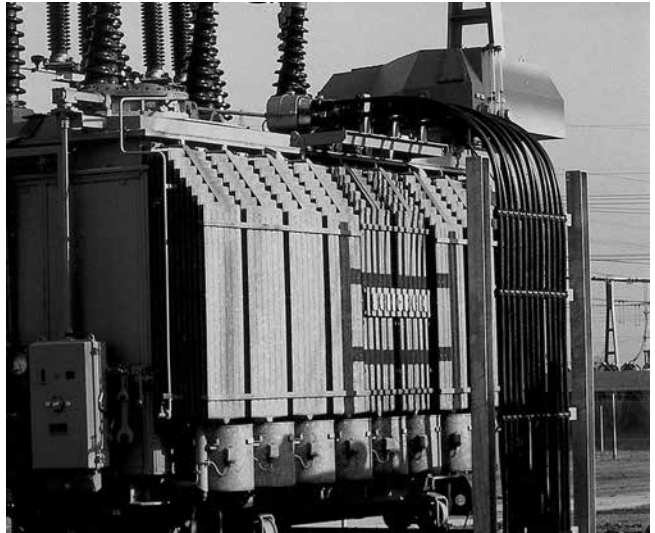
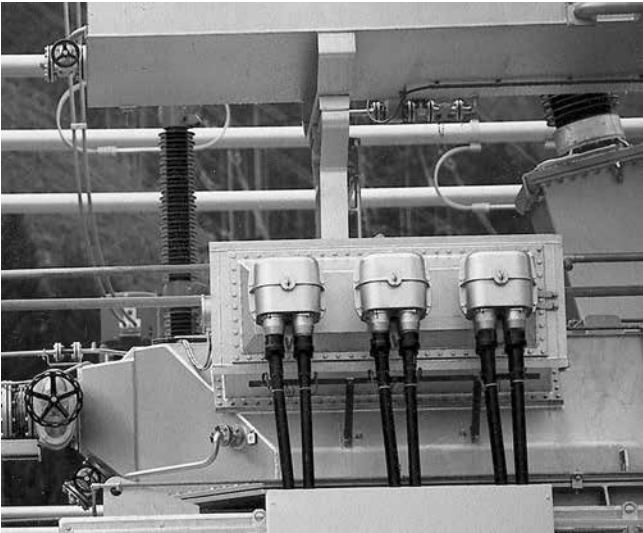
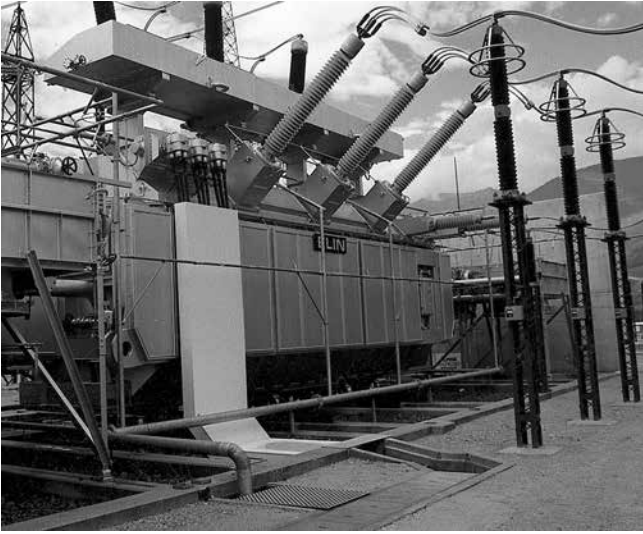

MV-CONNEX Quadruple-Contact Elbow Bushings, up to 52 kV

For plug-in and clamping type construction respectively.
With aluminium housing.

A Plug-in type connecting part.

B Clamping type connecting part (supplied by the transformer manufacturer)

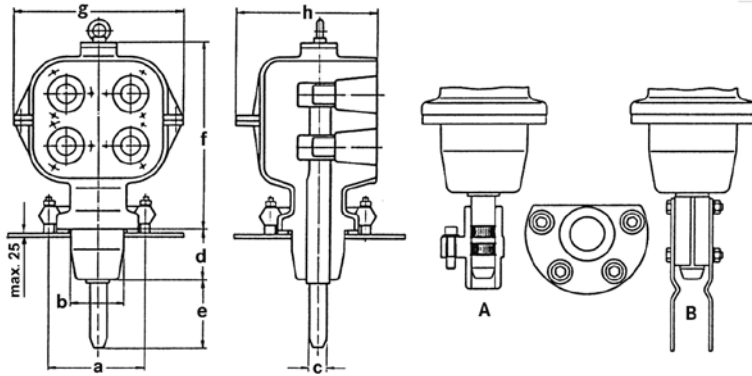

No.	Size	Max. operating voltage	max. rated current with plug-in type connection in transformer - type A	max. rated current with clamped connection in transformer - type B	a	b	c	d	e	f	g	Cone
	U _m (kV)	max. I _N (A)	max. I _N (A)	(mm)	(mm)	(mm)	(mm)	(mm)	(mm)	(mm)	(mm)	
827 124 715	2	36	1250	1250	180	110	30	125	90	387	345	slim
827 124 723	2	36	2200	3150	200	135	35	125	125	387	345	standard
827 124 823	2	36	2200	3150	200	135	35	300	125	387	345	long ¹⁾
827 124 716	2	42	1250	1250	180	110	30	125	90	387	345	slim
827 124 727	2	42	2200	3150	200	135	35	125	125	387	345	standard
827 124 827	2	42	2200	3150	200	135	35	300	125	387	345	long ¹⁾
827 146 335	3	36	2200	2500	200	135	35	125	125	449	390	standard
827 146 835	3	36	2200	2500	200	135	35	300	125	449	390	long ¹⁾
827 146 336	3	42	2200	3150	200	135	35	125	125	449	390	standard
827 146 836	3	42	2200	3150	200	135	35	300	125	449	390	long ¹⁾
827 146 337	3	52	2200	3150	200	135	35	125	125	449	390	standard
827 146 837	3	52	2200	3150	200	135	35	300	125	449	390	long ¹⁾

¹⁾ For current transformers for measuring purposes



Plug-in Type Connecting Part (A)

No.	for CONNEX 2x-elbow connecting parts	for CONNEX 4x-elbow connecting parts	for connection	Weight	a
			bolt diameter	(kg)	(mm)
			Ø (mm)		
827 128 710	827 661 002	827 124 715	30	2.5	180
	827 661 005	827 124 716			
827 128 730	827 660 001	827 124 723	35	2.8	200
	827 660 002	827 124 727			
	827 660 003	827 124 823			
	827 660 004	827 124 827			
	827 660 006	827 146 335			
	827 660 007	827 146 336			
	827 661 001	827 146 337			
	827 661 004	827 146 835			
	827 661 006	827 146 836			
	827 661 007	827 146 837			



1

Fixing set

For save fixing and sealing of MV-CONNEX Elbow Bushings at transformers. Comprises a flange ring, flat gasket, spring washers and hexagon nuts. According to DIN 42538.

No.	for CONNEX 2x-elbow connecting parts	for CONNEX 4x-elbow connecting parts	a		
			(mm)		
827 190 016	827 661 002	827 124 715	180	-	1
	827 661 005	827 124 716			
827 190 015	827 660 001	827 124 723	200	-	1
	827 660 002	827 146 335			
	827 660 003	827 124 727			
	827 660 004	827 124 823			
	827 660 006	827 124 827			
	827 660 007	827 146 336			
	827 661 001	827 146 337			
	827 661 004	827 146 835			
	827 661 006	827 146 836			
	827 661 007	827 146 837			
	827 190 116	827 661 002			
827 661 005		827 124 716			
827 190 115	827 660 001	827 124 723	200	offshore-proof	2
	827 660 002	827 124 727			
	827 660 003	827 124 823			
	827 660 004	827 124 827			
	827 660 006	827 146 335			
	827 660 007	827 146 336			
	827 661 001	827 146 337			
	827 661 004	827 146 835			
	827 661 006	827 146 836			
	827 661 007	827 146 837			



2

MV-CONNEX Elbow Bushings

For switch gears and motors.
Fasten with 4 fillister head screws (included in the scope of delivery)

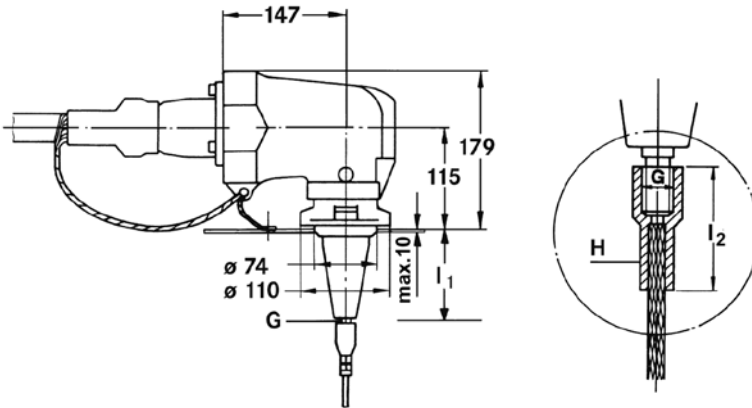

No.	Size	Nominal current I_N (A)	Max. operating voltage air U_m (kV)	Max. operating voltage SF ₆ -gas U_m (kV)	Max. operating voltage oil U_m (kV)	Thread G	Weight (kg)	l_1 (mm)
827 109 107	0	250	6	24	24	M10	6.5	107
827 119 107	1	630	6	36	36	M16	4.9	107

Compression Sleeves

Only these compression sleeves are approved for connection of MV-CONNEX elbow bushings.
For use with hexagonal compression dies.

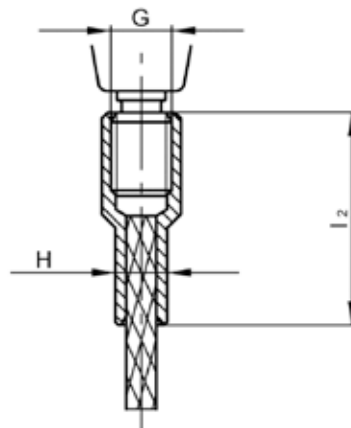

No.	for size	Cross section Cu strand wire (mm ²)	Diameter Cu strand wire according to DIN 46438 Ø (mm)	Diameter Cu strand wire according to DIN 60228 Ø (mm)	Pressing tool for thread G	Pressing tool for Cu strand H	l_2 (mm)
560 320 001	0	10	5.0	4,5 - 5,0	KZ 14	KZ 8	35 1
560 320 007	0	35	10.0	8,6 - 9,2	KZ 16	KZ 14	42 1
560 320 005	0	70	14.2	12,6 - 13,1	KZ 16	KZ 18	70 1
560 320 002	1	10	5.0	4,5 - 5,0	KZ 20	KZ 8	38 2
560 320 003	1	35	10.0	8,6 - 9,2	KZ 20	KZ 14	42 2
560 320 004	1	50	12.0	10,0 - 11,0	KZ 20	KZ 16	42 2
560 320 006	1	120	19.5	(16,2 - 17,0) ^{*)}	KZ 22	KZ 25	70 2
560 320 006	1	150	-	18,0 - 19,0	KZ 22	KZ 25	70 2

*) The diameters of the CU-stranded wires are to be re-crimped with the next smaller tool code (KZ 25 + KZ 22)



MV-CONNEX Sockets up to 52 kV

MV-CONNEX Bushings

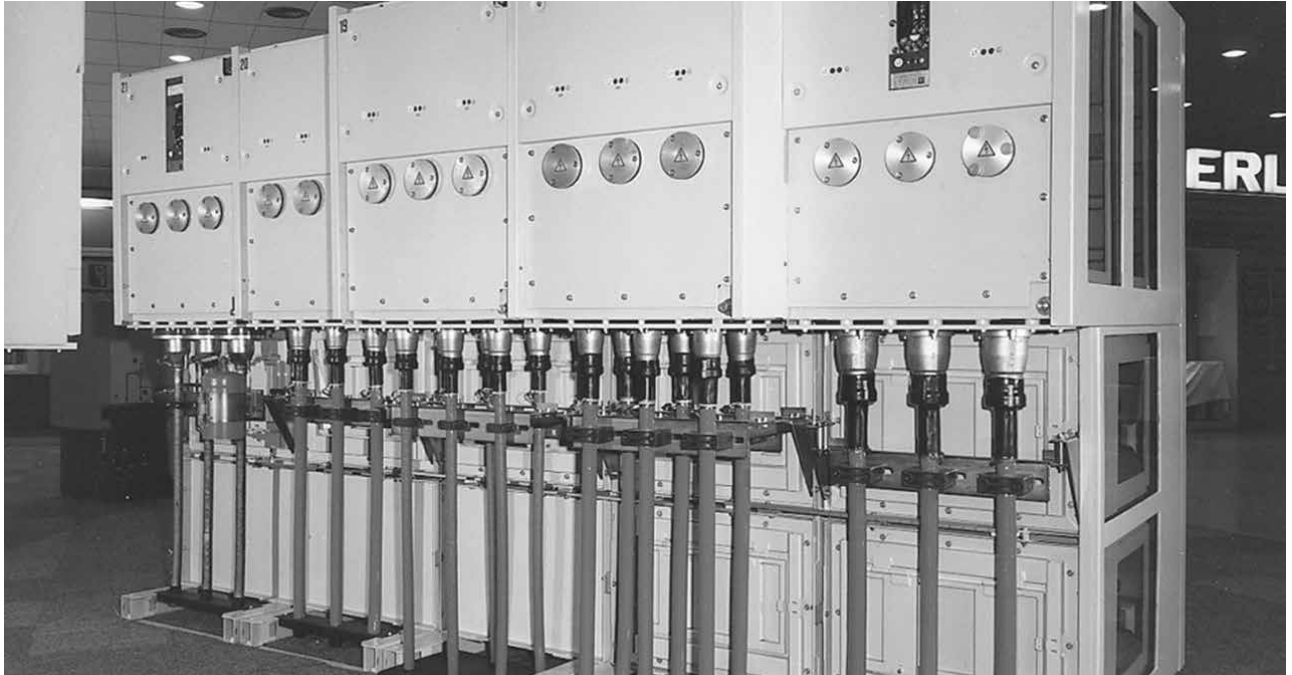

MV-CONNEX Sockets, up to 42 kV, hexagonal

For use in:
Switching stations, circuit breaker units, high-voltage motors, condensers, and other appliances.
Insulating medium: SF₆ gas
max. operating temperature of insulating medium: 90°C



No.	No. with sealing and fixing set	Sealing Form	Size	Max. operating voltage U _m (kV)	Nominal current I _N (A)	Capacitive voltage tap (pF)	Weight (kg)
827 106 401	827 106 601	hexagonal	1	36	630	—	2
827 106 411	827 106 611	hexagonal	1	36	630	8,5 ± 1,5	2
827 106 402	827 106 602	hexagonal	2	42	800	—	2.1
827 106 412	827 106 612	hexagonal	2	42	800	8,5 ± 1,5	2.1

MV-CONNEX Sockets, up to 42 kV, round version

For use in:
Switching stations, circuit breaker units, high-voltage motors, transformers, condensers, connecting sleeves and other appliances.
suitable for use in transformers
Insulating medium: SF₆ gas or oil
max. operating temperature of insulating medium: 110°C



Attention: With XLPE-insulated cable the max. temperature of the conductor must not be higher than 90°C.

No.	No. with sealing and fixing set	Sealing Form	Size	Max. operating voltage U _m (kV)	Nominal current I _N (A)	Capacitive voltage tap (pF)	Weight (kg)
827 104 005	827 104 205	round	2	42	800	—	2.8

MV-CONNEX Sockets, up to 52 kV, hexagonal

For use in:
Switching stations, circuit breaker units, high-voltage motors, condensers, connecting sleeves and other appliances.

Insulating medium: SF₆ gas or oil
max. operating temperature of insulating medium: 90°C



Attention: With XLPE-insulated cable the max. temperature of the conductor must not be higher than 90°C.

No.	No. with sealing and fixing set	Sealing Form	Size	Max. operating voltage U _m (kV)	Nominal current I _N (A)	Capacitive voltage tap (pF)	Weight (kg)	Application
827 110 010	827 110 210	hexagonal	3	52	1250	—	4.6	GIS
827 110 011	827 110 211	hexagonal	3	52	1250	14,5 ± 1,5	5.2	GIS
827 110 012	827 110 212	hexagonal	3	52	1250	—	4.6	*) Transformer
-	827 110 214	hexagonal	3	52	1250	—	4.6	*) min. -40°C

*) Suitable for use in transformers.

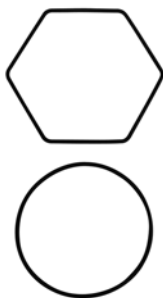

O-Ring Sealings

No.	suitable for	Dimensions (mm)	Form	Material
021 937 087	827 106 401	112 x 4	hexagonal	EPDM
	827 106 411			
	827 106 402			
	827 106 412			
021 937 069	827 110 010	137 x 4	hexagonal	FKM (Viton)
	827 110 011			
	827 110 012			
021 937 070	827 104 005	118 x 4	round	FKM (Viton)



MV-CONNEX Insulator, up to 24 kV

For indoor installation.

By using MV-CONNEX Insulators air-insulated switching stations can be equipped with shock-proof cable connections. Switching and cable connection areas can thus be easily sheltered.

The size 1 and 2 MV-CONNEX Insulators are suitable to be fitted to sheets that are 2 - 2.5 mm thick.

Breaking force $P_n = 5\text{ kN}$

Creepage distance 340 mm

Suitable for outdoor use up to $U_m = 6\text{ kV}$

BIL 125 kV

AC-test 54 kV/1 min

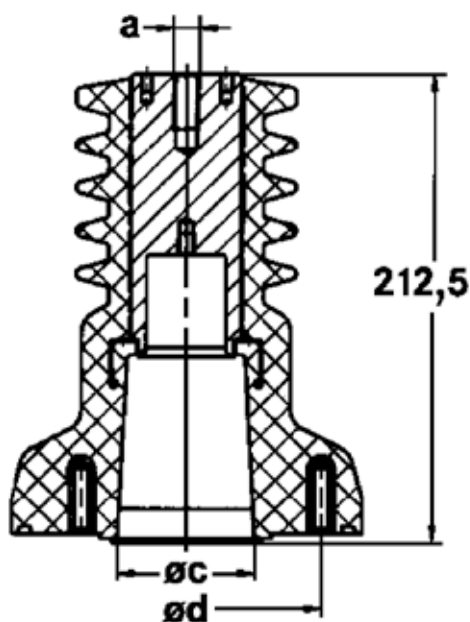

No.	Size	Max. operating voltage	Nominal current	Diame-ter c	Diame-ter d	Terminal pin	Weight (kg)	
		U_m (kV)	I_n (A)	\varnothing (mm)	\varnothing (mm)			
827 113 011	1	24	630	62	95	M12	3.9	Silicone-free production process
827 113 001	1	24	630	62	95	M12	3.9	-
827 113 003	2	24	800	68	102	M12	4.4	-

MV-CONNEX Insulator, up to 36 kV

The size 3 MV-CONNEX Insulators are suitable to be fitted to sheets that are 6 - 18 mm thick.

For indoor equipment.

Breaking force $P_n = 10$ kN
 Creepage distance 740 mm
 Suitable for outdoor use up to $U_m = 24$ kV
 BIL 170 kV
 AC-test 81 kV/1 min

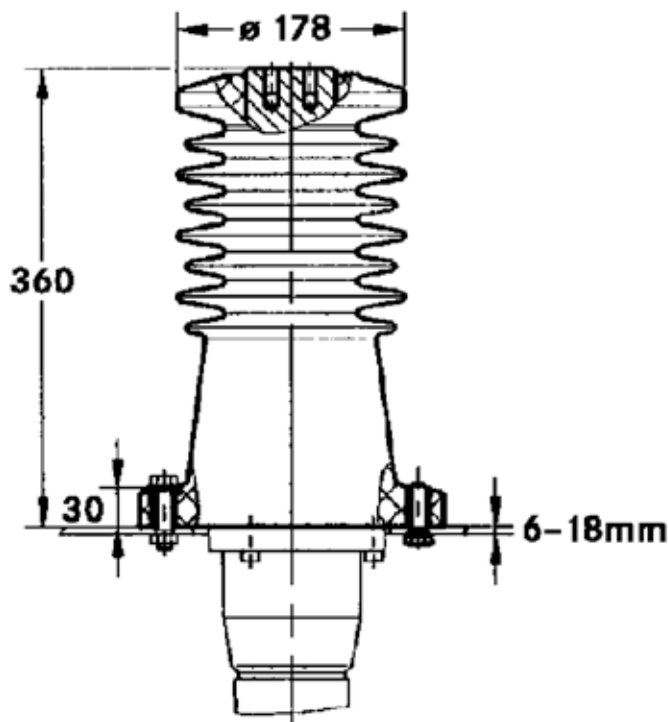

No.	Size	Max. operating voltage	Nominal current	Weight
		U_m (kV)	I_N (A)	(kg)
827 177 001	3	36	1250	17.6

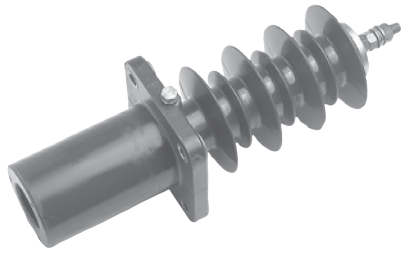

MV-CONNEX Outdoor Insulators

For tower substations.

The Outdoor Insulator permits the transition from the overhead line to the metal-enclosed touchproof cable termination inside tower substations. This insulator is designed as a bushing insulator with integrated female contact part for CONNEX separable connectors. Linked to other metal-enclosed equipment such as

- CONNEX elbow adapters
- CONNEX separable connectors
- CONNEX transformer bushings
- transformer terminal clamps with covers
- metal-enclosed ring main units

the outdoor insulator offers the possibility of an absolutely intrinsically safe construction of tower substations.

Cantilever strength $P_n = 5 \text{ kN}$.

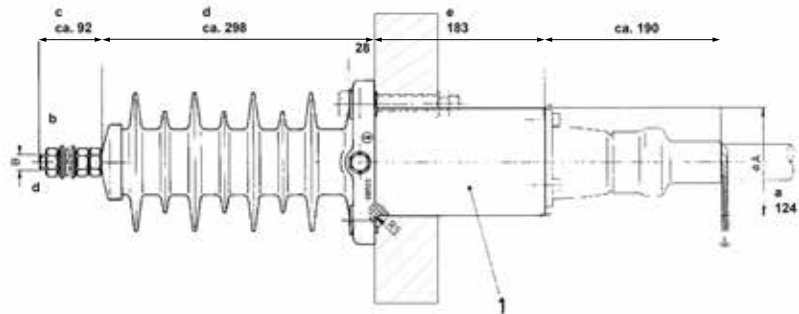

No.	Size	Max. operating voltage U_m (kV)	Nominal current I_N (A)	Terminal Bolt	Weight (kg)	a (mm)	c (mm)	d (mm)	e (mm)
827 173 002	2	24	800	M24	13	124	92	298	183

FLINK busbar Coupling System

To connect (coupling) the bus-bar of SF₆-insulated switchgears.

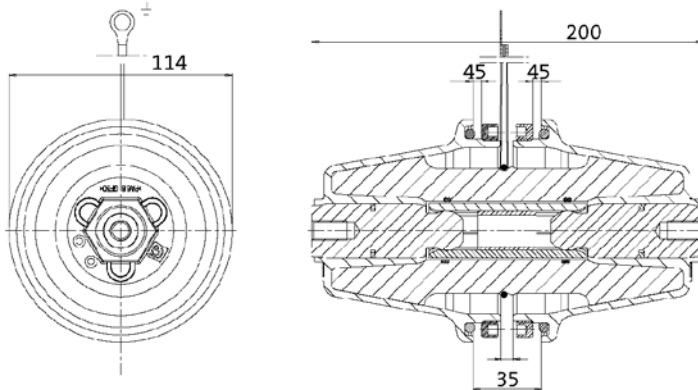

Bus-Bar Couple System

No.		Max. operating voltage	Nominal current	Weight	Packing unit	
		U _m (kV)	I _N (A)	(kg)		
819 001 024	Coupling plug	24	630	0.8	1	1
839 001 024	Coupling plug	24	630	2.4	3	1
819 002 002	Socket including sealing and securing ring	24	630	0.6	1	2
839 002 002	Socket including sealing and securing ring	24	630	1.9	3	2
819 003 001	Dummy Plug	24	630	0.4	1	3
839 003 001	Dummy Plug	24	630	1.2	3	3

Busbar Coupling System, Size 2 compatible

To connect (coupling) the bus-bar of SF₆-insulated switchgears.
Application only with CONNEX-socket size 2 with voltage tap which must always be earthed

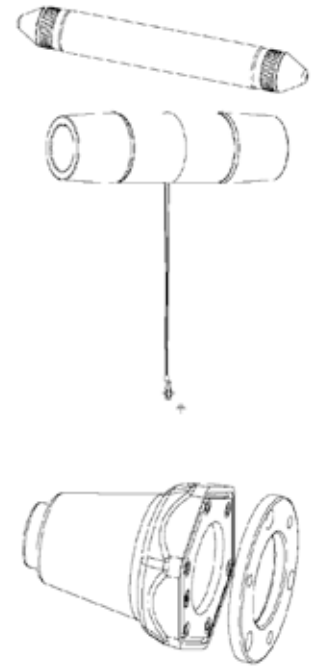
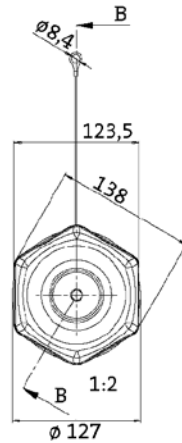
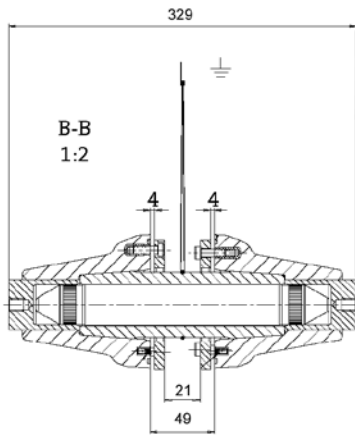

No.	Size	Max. operating voltage		Nominal current	Weight	Packing unit
		U _m (kV)	I _N (A)			
839 004 004	Coupling plug, incl. ground wire	2	42	800	4.3	3
839 005 001	CONNEX Socket, with voltage tap (827 106 412), incl. fastening flange (566 432 001), seal (021 937 087), screw (023 476 002), grounding spring (612 927 033)	2	42	800	6.4	3
839 004 006	Busbar coupling plug, incl. ground wire	2	42	1250*)	10	3
839 005 002	CONNEX Socket, with voltage tap (827 106 812), incl. fastening flange (566 432 001), seal (021 937 087), screw (023 476 002), grounding spring (612 927 033)	2	42	1250	6.4	3

*) only with sockets with voltage tap and copper contact bushing (No. 827 106 812)

MV-CONNEX Cable Joints

For outdoor, offshore and underground application.

Caution:

For use underground or offshore the bell flanges of the separable connectors must be made of bronze.

Single-pole, resistant to outdoor, soil-resistant, offshore-proof, plug-in type.

The single-pole connection sleeve is supplied as factory-built; the contact bushings are integrated into the soil-resistant insulating body. The connection is established by inserting the CONNEX separable connector.

Size 3

Cast shieldings guarantee short-circuit-resistant cable screen up to max. 95 mm².



No.	Size	Max. operating voltage	Nominal current	Type	Length l (mm)	Diameter Ø (mm)	Breite b (mm)	Höhe (mm)	Weight (kg)		
		U _m (kV)	I _N (A)								
827 212 001	1	36	630	not insulated against the soil	263	143	-	-	5.8	1	A
827 212 002	1	36	630	Not soil sensitive *	263	143	-	-	6.4	1	B
827 222 001	2	42	800	not insulated against the soil	263	143	-	-	5.8	1	A
827 222 002	2	42	800	Not soil sensitive *	263	143	-	-	6.4	1	B
827 228 001	3	52	1250	not insulated against the soil	565	-	204	209	28	2	

*) The use of a heat-shrink tubing at the CONNEX separable connectors eliminates the soil sensitivity. The shrink tubing is provided. (B) Soil sensitivity can not be eliminated at size 3. (Shrinking on a heat-shrink tubing is not possible with cable joint size 3.)



1 MV-CONNEX-T-Joint

Single-pole, metal clad, for outdoor use, soil resistant.

In the event of network modifications, the underground T-joints can be replaced by CONNEX joints.

Using this T-joint and the CONNEX coupling connector *), switching stations that are equipped with CONNEX sockets can later be expanded to become double connections. In addition, a plug-in cable branch wire can also be realised.

The single-pole T-joint is provided wired ready for connection. The CONNEX contact bushings are integrated in the soil-resistant insulating bodies.

The connection is established by inserting the CONNEX separable connector. Cast shieldings additionally guarantee a short-circuit-resistant cable screen connection.

2

*) MV-CONNEX Coupling Connector is available only in size 2

3

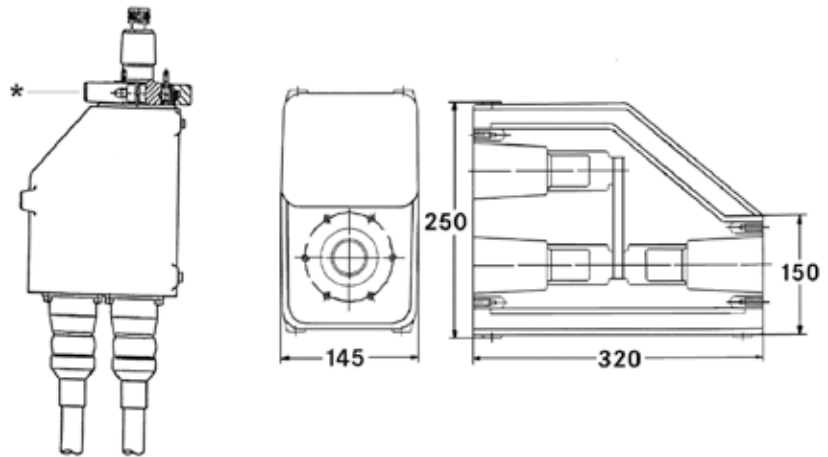

No.	Size	Max. operating voltage	Nominal current	Ausführung	Weight	
		U_m (kV)	I_N (A)			
827 147 001	1	36	630	with metal housing, not soilproof	21	1
827 147 002	2	42	800	with metal housing, not soilproof	21	1
827 221 001	1	36	630	soilproof	17.6	2
827 221 002	2	42	800	soilproof	17.6	2
827 227 001	3	52	1250	soilproof	46	3

MV-CONNEX Coupling Connector, up to 42 kV

For the coupling of equipment and switchgear. This coupling connector permits easy electric coupling of different components fitted with CONNEX sockets.

The metal flange assures that the mechanical connection of the two components is coupled at minimum distance.

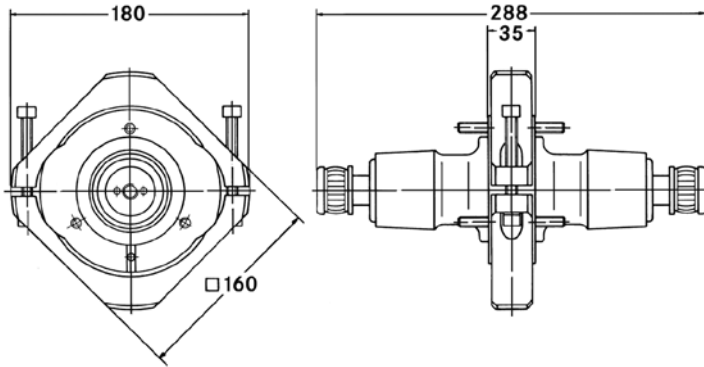

No.	Size	Max. operating voltage		Nominal current	Weight
		U_m (kV)		I_N (A)	(kg)
827 138 002	2	42		800	4.2

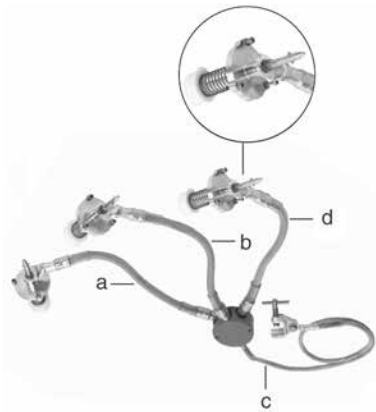

Earthing and Short-Circuiting Devices

These devices permit the grounding and short-circuiting of equipment fitted with CONNEX sockets (e.g. switchgear, transformers) and cable, fitted with CONNEX Separable Connectors.

Earthing and Short-circuit device for MV-CONNEX Sockets

Earthing and Short-Circuiting Devices, three-pole, matching CONNEX Sockets acc. to EN 50180, EN 50181, DIN 47 637

Application:

Indoor and outdoor use

Other variants on request.

No.	Variante	Size	Max. short-circuit current I_k 1s (kA)	Cable cross section (mm ²)	Cable lengths a/b/d/c (mm)	Line screw clamp	Earthing clamp
369 203 001	0164	1	29.5	150 / 50	600/600/600/1500	Connection for CONNEX-Socket Size 1	E2
369 203 001	0180	2	29.5	150 / 50	600/600/600/1500	Connection for CONNEX-Socket Size 2	E2
369 203 001	0146	3	29.5	150 / 50	600/600/600/1500	Connection for CONNEX-Socket Size 3	E2

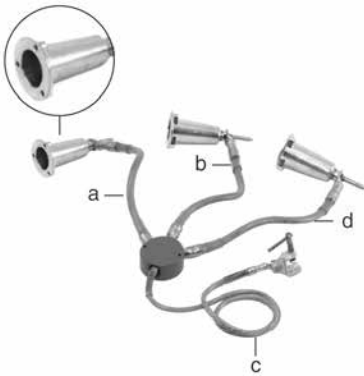

Earthing and Short-circuit device for CONNEX Separable Connectors

Earthing and Short-Circuiting Devices, three-pole, matching CONNEX Separable Connectors.

Application:
Indoor and outdoor use

Other variants on request.

No.	Variante	Size	Max. short-circuit current I_k 1s (kA)	Cable cross section (mm ²)	Cable lengths a/b/d/c (mm)	Line screw clamp	Earthing clamp
369 203 001	0182	1	29.6	150 / 50	600/600/600/1500	Connection for CONNEX-Plug Size 1	E2
369 203 001	0221	2	29.6	150 / 50	600/600/600/1500	Connection for CONNEX-Plug Size 2	E2
369 203 001	0181	3	29.6	150 / 50	600/600/600/1500	Connection for CONNEX-Plug Size 3	E2

Tilting operating pole

Tilting operating pole for CONNEX Earthing and Short-circuit devices (to be ordered separately).

No.	Length l (mm)
827 137 001	513
827 148 001	1006



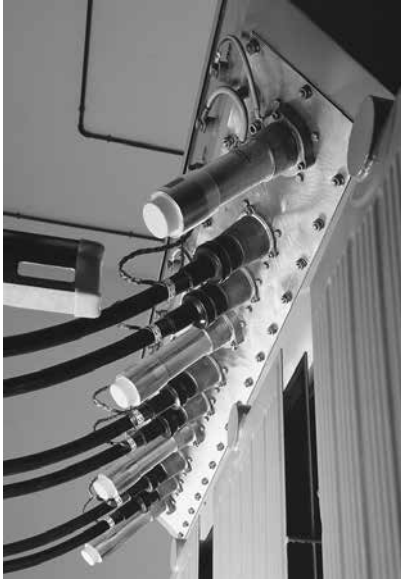

MV-CONNEX Surge Arrester

Features of MV-CONNEX Surge Arrester, pluggable

- Metal-enclosed
- Fully-insulated
- touchproof
- free from arcing
- High short-circuit protection
- Maintenance-free
- For outdoor and offshore use
- Protection class IP 66

Scope of Application

CONNEX surge arresters are used for the protection to metal-enclosed switchgears and transformers equipped with plug-in type bushings acc. to EN 50180 / 50181. The separable surge arrester is installed on the switchgear/transformer to prevent the intake of unduely high overvoltages. The surge arrester limits particularly those overvoltages that are produced by the reflection of traveling waves. **When using these surge arresters for switchgears/transformers connected to the transmission line via a cable route, it is necessary to protect the transition between the cable and the transmission line with suitable arresters. The capacity of protection is specially coordinated with the switchgear's resistance to surge voltages, considering at the same time the space arrangement and the level of electrical protection.**

Specifications

The Standard for surge arresters IEC 60099-4 is applicable to these devices. The dimensions of the plug-in termination system comply with EN 50180/EN 50181.

Design

The live part consists of metal oxide resistors without spark gap. The resistors possess a high thermal stability ensured by suitable dimensioning. These live parts are enclosed by a silicone rubber jacket that provides insulation against the metal housing. The corrosion-resistant aluminium housing renders the surge arrester intrinsically safe and thus assures optimal safety for operating personnel. The metal housing provides a hermetic sealing of the live parts against environmental influences, such as moisture or pollution. The plug-in connector is designed to fit the inside cone plug-in termination system acc. to EN 50180/ EN 50181. It is available in sizes 1, 2 and 3. The arrester is equipped to a corrosion-resistant fracture membrane that opens the arrester in case of an internal fault and allows a defined axial pressure relief on the rear end of the arrester without damaging the plug-in system.

Selection parameters

The following principle must be applied when selecting a suitable surge arrester:

1. The **continuous operating voltage** U_c must be higher than the maximum voltage permanently allowed on arrester terminals.
2. The **residual voltage** U_{res} of the surge arrester must be lower than the protection level of the operating equipment.
3. The **temporary over voltages** must be below than the TOV characteristic.

If a continuous voltage is too low, it may cause the arrester to fail, while a residual voltage that is too high can damage the operating system.

Selection of continuous operating voltage U_c

The continuous operating voltage U_c is the maximum voltage permanently allowed (> 30 min) on arrester terminals.

The selection of continuous voltage is dependent upon the grounding principle of the network:

Solidly earthed:

In a solidly earthed network, the phase earth voltage affects the continuous operating voltage. Due to harmonic waves in the sinusoidal voltage, a safety factor of 5 % is taken into account.

$$U_{c, \text{earthed grid}} = 1,05 * U_s / \sqrt{3}$$

Insulated/compensated grid:

In compensated or insulated grids, the continuous operating voltage U_c of the arrester must equal to the maximum system voltage U_s . This is to ensure continuing operation of the grid in the case of a single-phase earth fault.

$$U_{c, \text{insulated grid}} = U_s$$

Selection of the rated voltage U_r

The ratio of rated voltage and continuous operating voltage is $U_r/U_c = 1.25$.

Selection of residual voltage U_{res}

The residual voltage U_{res} is the maximum voltage at the arrester terminals when a current pulse is being discharged (e.g. 10 kA, wave form 8/20 μ s). The residual voltage must be correspondingly lower than the insulation coordination.

According to the insulation coordination, the residual voltage must be lower than the insulating capacity of the operating equipment. As a safety factor, 15 % has proven to be suitable.

$$U_{res, 10 \text{ kA}, 8/20\mu s} = 0,85 * U_{BIL, 8/20\mu s}$$

Temporary overvoltages

Due to alternating load and fluctuations in production, the voltage is kept within a regular range by means of step switches on transformers. Tracking the voltage back into the target range requires a control time. During the control time (few seconds), the voltage can be on the arrester terminals above the continuous operating voltage. Short-term exceedance of the continuous voltage is described in the TOV characteristic. The exceptional scenario of temporary overvoltage for 10 s is described by the rated voltage $U_{TOV, 10s} = U_r$.

see diagramm on page 60



TOV characteristics

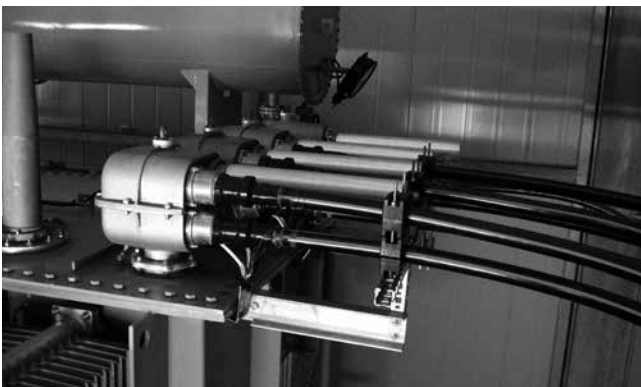
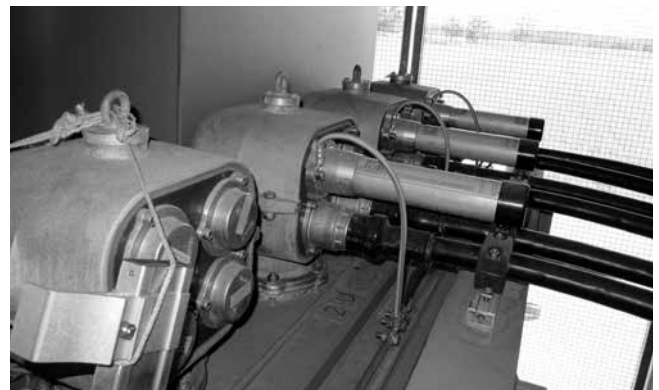
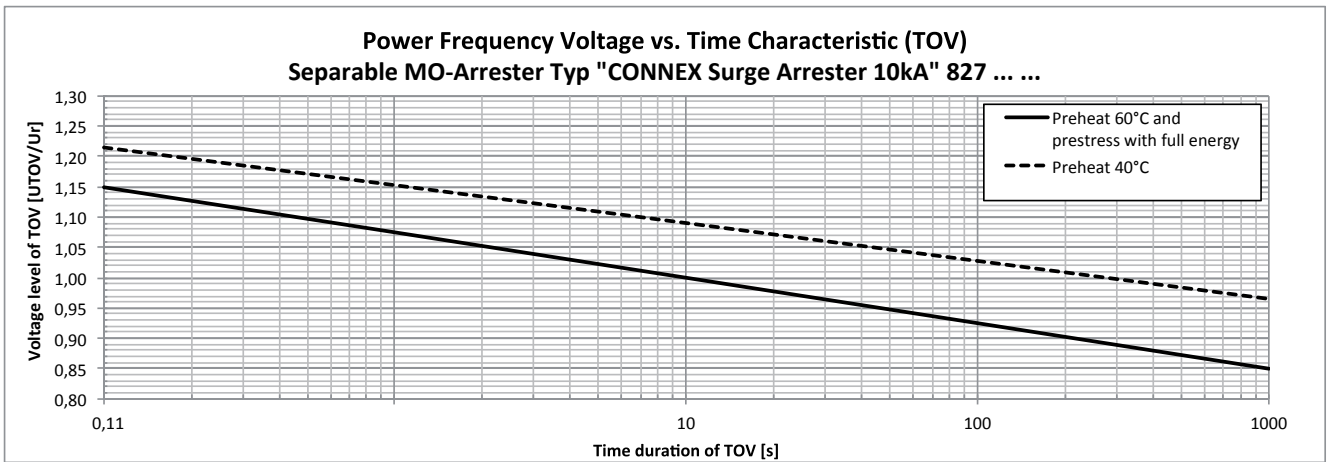

CONNEX Surge Arrester, 10 kA

Technical data

Line discharge class	1	High peak current	65 kA, 4/10 μ s
Energy absorption capacity	2 kJ/kV _{Ur}	Long-wave peak current	250 A, 2 ms
Rated discharge surge current	10 kA, 8/20 μ s	Short-circuit withstand current	16 kA, 0,2 s
		Earth return	min. 16 mm ²

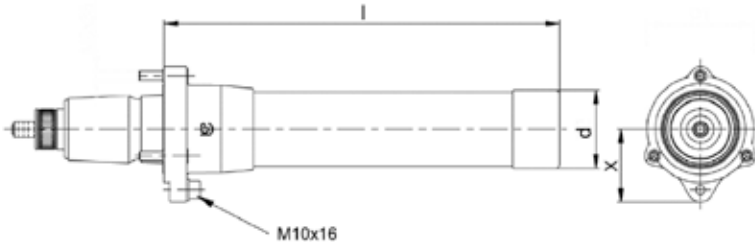

No.	Size	Rated voltage	Max. continuous rating	Max. residual voltage U _{res} at			Length l (mm)	Thickness d (mm)	Dimension x (mm)	Weight (kg)
		U _r (kV)	U _c (kV)	8/20 μ s/5 kA (kV)	8/20 μ s/10 kA (kV)	steep impulse 1/20 μ s (kV)				
827 513 075	1	7,5	6	20	22	23	350	66	66	3.5
827 513 090	1	9,0	7	24	26	29	350	66	66	3.5
827 513 125	1	12,5	10	34	37	40	350	66	66	3.5
827 513 150	1	15,0	12	40	44	47	350	66	66	3.5
827 513 175	1	17,5	14	47	51	55	350	66	66	3.5
827 513 190	1	19,0	15	51	56	60	350	66	66	3.5
827 513 215	1	21,5	17	58	63	67	350	66	66	3.5
827 513 240	1	24,0	19	64	70	75	350	66	66	3.5
827 513 300	1	30,0	24	80	87	94	350	66	66	3.5
827 513 360	1	36,0	29	96	105	112	350	66	66	3.5
827 523 075	2	7,5	6	20	22	23	350	66	66	3.7
827 523 090	2	9,0	7	24	26	29	350	66	66	3.7
827 523 125	2	12,5	10	34	37	40	350	66	66	3.7
827 523 150	2	15,0	12	40	44	47	350	66	66	3.7
827 523 175	2	17,5	14	47	51	55	350	66	66	3.7
827 523 190	2	19,0	15	51	56	60	350	66	66	3.7
827 523 215	2	21,5	17	58	63	67	350	66	66	3.7
827 523 240	2	24,0	19	64	70	75	350	66	66	3.7
827 523 300	2	30,0	24	80	87	94	350	66	66	3.7
827 523 360	2	36,0	29	96	105	112	350	66	66	3.7
827 527 450	2	45,0	36	120	131	140	500	98	66	4.4
827 527 510	2	51,0	40.8	134	147	158	500	98	66	4.4
827 527 525	2	52,5	42	139	152	163	500	98	66	4.4
827 537 075	3	7,5	6	20	22	23	490	98	80	5.2
827 537 091	3	9,0	7	24	26	29	490	98	80	5.2
827 537 125	3	12,5	10	34	37	40	490	98	80	5.2
827 537 150	3	15,0	12	40	44	47	490	98	80	5.2
827 537 175	3	17,5	14	47	51	55	490	98	80	5.2
827 537 190	3	19,0	15	51	56	60	490	98	80	5.2
827 537 215	3	21,5	17	58	63	67	490	98	80	5.2
827 537 240	3	24,0	19	64	70	75	490	98	80	5.2
827 537 300	3	30,0	24	80	87	94	490	98	80	5.2
827 537 360	3	36,0	29	96	105	112	490	98	80	5.2
827 539 450	3	45,0	36	120	131	140	490	98	80	5.2
827 539 510	3	51,0	40.8	134	147	158	490	98	80	5.2
827 539 525	3	52,5	42	139	152	163	490	98	80	5.2

CONNEX Motor Connector (CMA) / CONNEX Star Point Connector (CMS), Size 1

Special features

- metal-enclosed
- fully-insulated
- touchproof
- high short-circuit protection
- suitable for outdoor use
- separable into two parts
- degree of protection IP 66
- up to 11 kV Ex

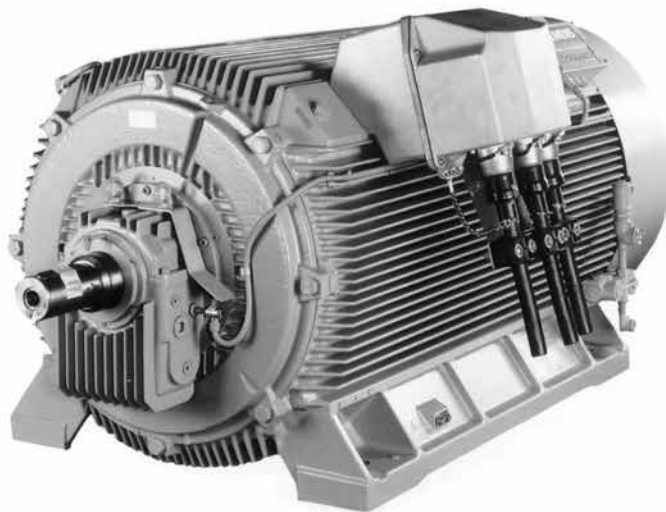
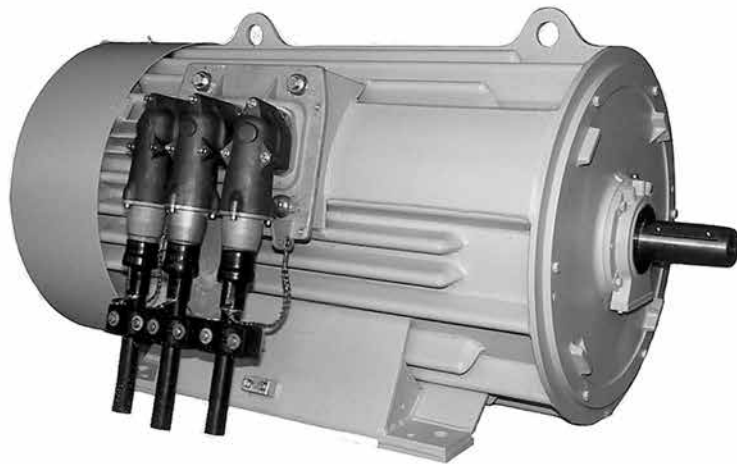

CONNEX Motor Connector (CMA) / CONNEX Star Point Connector (CMS), Size 1

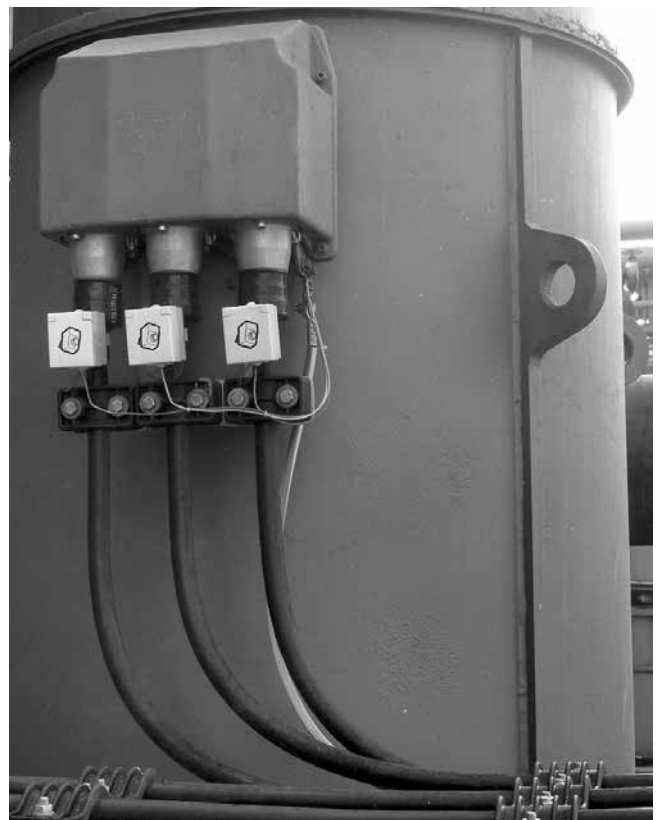
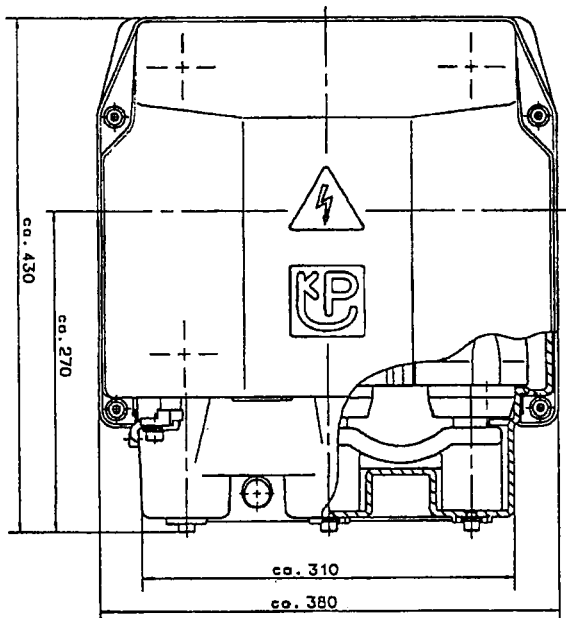
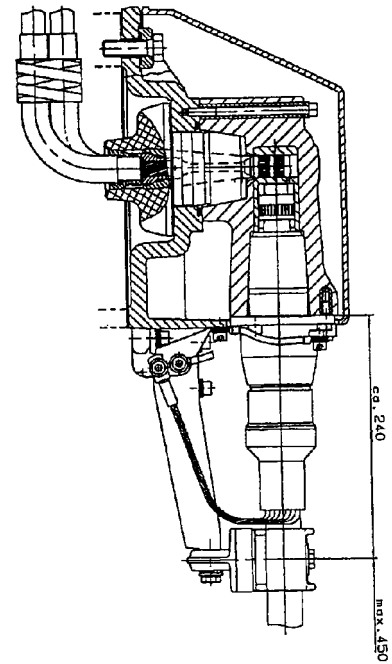
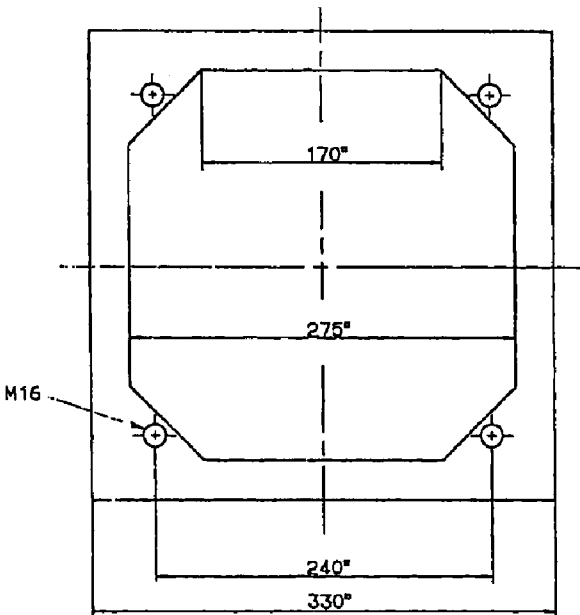

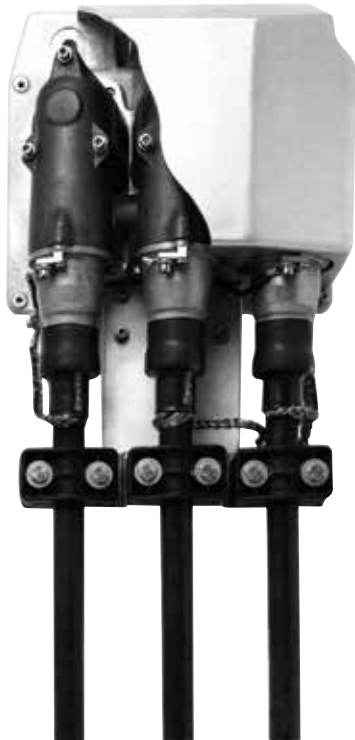

CMA CONNEX Motor Connector, Size 1

The CMA CONNEX Motor Connector permits the simple and quick connection of high-voltage motors, providing at the same time a completely metal clad and touchproof connector area.

The system is easily connected instead of the motor terminal box. It permits quick start-up and quick motor change in operation.

Attention:

CONNEX separable connectors size 1 for single and three core cables up to 10 kV/240 mm² respectively 20 kV/185 mm² must be ordered separately.

No.	Nominal voltage		Weight (kg)
	U ₀ / U (kV)		
827 670 002	13.8	-	33.5
827 670 003	11	Ex	32.6

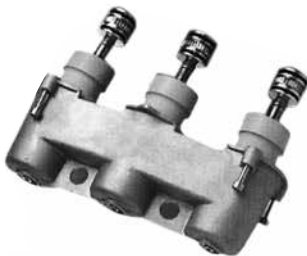

CMS CONNEX Motor Star Point Connector, Size 1

The CMS CONNEX Star Point Connector allows a simple and quick metal-enclosed and touchproof star point connection. Thereby, the on-site change from the connecting side to the star-point side of the motor can occur easily. Interchangeability of cable connection and star point connector on the HV motor.

Important:

Basic CMA equipment must be ordered separately for this „neutral bridge“!

No.	Nominal voltage		Weight (kg)
	U ₀ / U (kV)		
827 671 002	13.8	-	5,6
827 671 003	11	Ex	5,6

Assembly Accessories

Assembly Tools for CONNEX Motor Connector

consisting of:
assembly jig; drawing device; soldering device; assembly rods

No.
827 154 001

Disassembly Bridge and Assembly Lever

for CONNEX Motor Connector and Star Point Bridge

No.
827 154 002



Voltage Detecting Systems

Voltage detecting systems that meet Standard EN 61243-5:2001 are used for ensuring absence of voltage in metal-clad switchgear and transformers. As the live components in these systems cannot be contacted with voltage detectors, it is necessary to use voltage detecting systems that can clearly identify and indicate a capacitively sensed signal as an operating voltage. This signal is sensed by the integrated coupling electrodes that may be integrated in various components:

- Post-type insulator with capacitive voltage divider
- Transducer
- Bushings
- Duresca rails
- Outside/inside tapered cable terminations

Voltage detection systems used for both medium and high voltage.

Standard EN 61243-5:2001 generally distinguishes between two systems defining the interface conditions for the reliable operation of voltage detecting systems:

- HR systems (high resistance system)
- LRM systems (low resistance systems)

PFISTERER supplies the following components for both systems:

- Voltage detecting systems
- Connection materials such as connecting cables and connector strips
- Testing systems for testing voltage detecting systems
- Testing systems for testing interfaces
- Phase comparators

Our voltage detection systems are optimised for PFISTERER CONNEX connection technology components.

Indicators

These indicators show when operating voltage is present.



Continuous Voltage Indicator DSA-2

The **DSA-2 continuous voltage indicator** is a plug-in indicator for the HR system. It allows absence of voltage to be checked on the basis of capacitively sensed voltages.

Technical description:

- No external power required
- Voltage indicator with flashing red LED
- Insulated system (IP66) made of impact-resistant plastic with moulded Europlug
- Function test possible on 230 V AC plug sockets
- EURO-Test HR in-service test possible
- Suitable for all climate zones

No.

827 161 005



Continuous Voltage Indicator DSA-LRM

The **DSA-LRM continuous voltage indicator** is a plug-in indicator for the LRM system. It allows absence of voltage to be checked on the basis of capacitively sensed voltages.

Technical description:

- No external power required
- Voltage indication by flashing red LED
- Insulated system (IP66) made of impact-resistant plastic
- Integrated connector pins with seal for interface
- In-service test possible with Euro-Test LRM
- Suitable for all climate zones

No.

827 020 001

Integrated Voltage Detecting Systems DSA-i3

The DSA-i3 integrated voltage detecting system has an integrated indicator. It is designed for integration in switchgear cabinets. An additional display makes in-service tests unnecessary. This voltage detecting system is therefore particularly maintenance-free, reliable and cost-effective when used in continuous operation.

Exact matching of DSA-i3 and the coupling capacitance C_1 can be achieved by selection of the additional capacitance C_{2L} .

Technical description:

- No external power supply required
- Red LCD display
- Test sockets available for phase comparison
- Additional third socket for testing the integrated LCD display
- Secure cover for sockets
- Conscious test process using three buttons
- Integrated breaking point for voltage-limiting
- Simple assembly
- No test repetition required
- Interface adaptation possible by means of additional capacitances
- Protection class IP 66
- Operating temperature -25...+55°C
- Dimensions (mm): width 96 x height 48 x depth 30

No.	Variante	Nominal frequency	Threshold voltage	Input impedance	Additional capacitance C_{2L}
		f_N (Hz)	(V)	(MΩ)	(nF)
827 216 004	0008	50...60	4...5	2	—
827 216 004	0007	50...60	4...5	2	2,2
827 216 004	0006	50...60	4...5	2	3,3
827 216 004	0005	50...60	4...5	2	10
827 216 004	0009	50...60	4...5	2	33
827 216 004	0010	50...60	4...5	2	47

Assembly Bracket

This practical assembly bracket is available for mounting the DSA-i3 integrated voltage detection system outside front panels.

No.

993 008 002

Coaxial cable RG58 connection set

No.	Variante	Connector set with
564 430 010	0013	Angle Plug
564 430 010	0033	Plug sleeve 4.8-1-Bz gal Sn
564 430 010	0089	Flat connector A4.8-1-Bz gal Sn
564 430 010	0036	Ring cable lug A5-2,5-Bz gal Sn
564 430 010	0030	Plug sleeve 4.8-10,8-Bz gal Sn
564 430 010	0010	without connector

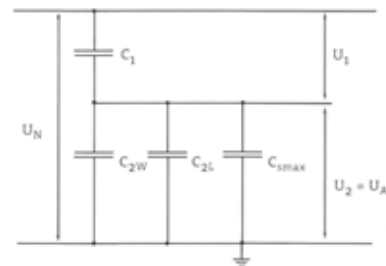
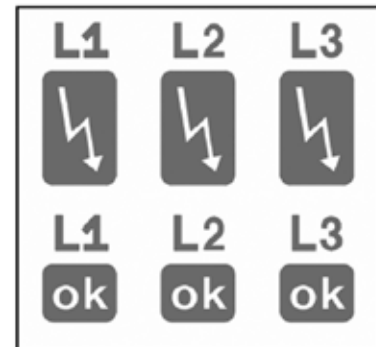



Interfaces and Connecting Leads

PFISTERER offers a range of interfaces and connecting leads for connecting indicators. Connecting leads on request.

Three-Pole Interfaces for HR-System

This **three-pole interface for HR systems** is designed as a measuring and testing block with safety test socket and earthing socket. It can be mounted on switchgear.

Note:

To meet the standard, this interface must also be equipped with a voltage limiting predetermined breaking point. The interface, the terminals on the coupling element, and the voltage limiting predetermined breaking point must be individually protected against humidity.

No.

560 915 001



Single-Pole Interface for HR-System

This **single-pole interface for HR systems** is designed as a test socket. It can be mounted anywhere near the capacitive tap.

Note:

The standard requires that this interface is also to be equipped with a voltage limiting predetermined breaking point. The interface, the terminals on the coupling element, and the voltage limiting predetermined breaking point must be individually protected against humidity.

No.

827 668 001

HR-Test Point Module

Integrated measuring circuit components, overvoltage protection, standard protective barriers and timesaving installation are the characteristic features of these test point modules. Special versions of LRM test point modules can be configured on customer request.

No.	Capacitance (nF)	Length l (mm)	Surge Arrester in all modules
827 022 011	650	4500	-
827 022 012	450	6600	-



Test Point Module LRM

Integrated measuring circuit components, overvoltage protection, standard protective barriers and timesaving installation are the characteristic features of these test point modules. Special versions of LRM test point modules can be configured on customer request.

No.	Capacitance (nF)	Length l (mm)	Surge Arrester in all modules
827 027 008	3,6	3000	3,3nF
827 027 009	10,3	3000	10nF
827 027 018	0,67	6600	3,3nF
827 027 038	0,67	6600	3,3nF
827 027 036	3,9	6600	3,3nF
827 027 005	3,97	6600	3,3nF
827 027 040	3,97	6600	3,3nF
827 027 042	3,97	6600	3,3nF
827 027 006	10,7	6600	10nF
827 027 016	10,7	6600	10nF
827 027 026	10,7	6600	10nF
827 027 041	10,7	6600	10nF

Testers for Continuous Voltage Indicators

These testers can be used to carry out function tests on continuous voltage indicators. They can also be used for the in-service test. These testers are operated from a plug socket and, during the function test, simulate the minimum response threshold specified in the standard.

EURO-Test HR

This EURO-Test HR tester is suitable for checking the continuous voltage indicator of HR systems.

No.	Min. threshold voltage	Min. threshold current range	Permissible ambient temperature	Standby indication
	U_{min} (V)	I_{min} (μA)	($^{\circ}\text{C}$)	
827 160 001	90	2.5	-25 ... +55	LED



EURO-Test LRM

This EURO-Test LRM tester is suitable for testing the continuous voltage indicator of LRM systems.

No.	Min. threshold voltage	Min. threshold current range	Permissible ambient temperature	Standby indication
	U_{min} (V)	I_{min} (μA)	($^{\circ}\text{C}$)	
827 160 003	5	2.5	-25 ... +55	LED





Testers for Interfaces

These testers can be used for testing the interface.

MP-Test

This MP tester is suitable for testing the interfaces on HR systems and LRM systems. It can be used in connection with a multimeter.

No.

827 094 001



Testers for Continuous Voltage Indicators and Interfaces

PFISTERER offers testers for continuous voltage indicators and interfaces in a set.

Test Kit

This test kit contains testers for continuous voltage indicators and interfaces for the HR as well as the LRM system.

Technical description:

- Practical storage case with foam liners
- Multimeter
- MP test
- HR EURO test
- LRM EURO test

No.

827 092 002



Phase Comparators for Interfaces and Measuring Points

Phase comparators that meet standard EN 61243-5:2001 can be used to carry out phase comparisons on interfaces and measuring points.

Electronic Phase Comparators EPV

The **EPV electronic phase comparator** allows phase comparison at interfaces and measuring points. It can be used for the HR system as well as the LRM system. At the same time, it also allows checks for absence of voltage and tests on the interface.

Technical description:

- Integrated test leads
- Touch-safe testing
- Function test and battery check with integrated self-test
- Clear voltage indication by means of LEDs
- Active phase balance indication by two LEDs (green=phase balance; red=phase unbalance)
- Integrated safety function
- Interface control
- Manual or automatic shutdown of the device



No.	Variante	Scope of application	Nominal frequency f_N (Hz)	Adapter for HR-System	suitable bag
827 189 008	0006	LRM	50...60	827 217 002	970 318 003
827 189 008	0007	LRM	50...60	827 217 002	364 889 001

Two pole adapter LRM - HR-system

This two-pole adapter allows the phase comparator EPV to be used on HR interfaces.

No.

827 217 002

Bags

Two different types of bags are available for the electronic phase comparator EPV. Design 2 offers separate slip-in pockets for the phase comparator, the adapter and additional measuring cables.

No.

970 318 003

1

364 889 001

2



PFISTERER worldwide

PFISTERER

Kontaktsysteme GmbH
Rosenstraße 44
73650 Winterbach
Deutschland
Telefon +49 7181 7005 0
Telefax +49 7181 7005 565
info@pfisterer.de
www.pfisterer.de

PFISTERER S.A.

Av. Vélez Sarsfield 464
C1282AFR Buenos Aires
Argentinien
Telefon +54 11 4306 3595
Telefax +54 11 4362 2381
pfisterer@pfisterer.com.ar
www.pfisterer.com.ar

PFISTERER

Representative Office
Ruea Tripoli 92
Sala 122
05303-020 Sao Paulo
Brasilien
Telefon +55 11 3647 9317
Telefax +55 11 3647 9316
ipsouza@pfisterer.com.br
www.pfisterer.com.br

PFISTERER

**Power Connection Systems
Beijing Co. Ltd.**
Unit 520, Landmark Tower 2
8 North Dongsanhuan Road
Chaoyang District
Peking 100004
China
Telefon +86 10 6590 6272
Telefax +86 10 6590 6105
info.cn@pfisterer.com
www.pfisterer.cn

PFISTERER

**Power Connection Systems
(Wuxi) Co.**
No. 31 Jingma Road East
Daxin Cun Hongshan Sub District
Wuxi New District
214028 Wuxi, Jiangsu Xi
China
Telefon +86 510 85522080
www.pfisterer.cn

PFISTERER SAS

35 avenue d'Italie
68110 Illzach
Frankreich
Telefon +33 389 319029
Telefax +33 389 319028
info@pfisterer.fr
www.pfisterer.fr

PFISTERER Ltd.

Unit 9, Ellesmere Business Park
Off Swingbridge Road
Grantham N631 7XT
Großbritannien
Telefon +44 1476 578657
Telefax +44 1476 568631
info.uk@pfisterer.com
www.pfisterer.co.uk

PFISTERER s.r.l.

Via Sirtori 45 d
20017 Passirana di Rho (MI)
Italien
Telefon +39 02 93158 11
Telefax +39 02 93158 37
pfisterer@pfisterer.it
www.pfisterer.it

PFISTERER Ges.m.b.H.

Augasse 17
1090 Wien
Österreich
Telefon +43 1 3176531 0
Telefax +43 1 3176531 12
info@pfisterer.at
www.pfisterer.at

PFISTERER Sp. z o.o.

Ul. Pogodna 10
05-850 Piotrkówek Maly
Polen
Telefon +48 22 72241 68
Telefax +48 22 72127 81
info@pfisterer.pl
www.pfisterer.pl

PFISTERER Korea Branch

Room 1930
Kwanghwamun Officia Building
163 Shinmunro- 1ga
Jongno-Gu
Seoul 110-999
Republik Korea
Telefon +82 2 3276 2630
Telefax +82 2 3276 2631
info@pfisterer.kr
www.pfisterer.kr

PFISTERER

Representative Office
Krasnapresnenskaya nab., 12
Entrance No. 6, office no. 921
123610 Moskau
Russland
Telefon +7 495 258 13 50
Telefax +7 495 674 58 07
info.ru@pfisterer.com
www.pfisterer.ru

PFISTERER

Komponent & System AB
Flygfältsgatan 2 D
128 30 Skarpnäck
Schweden
Telefon +46 8 7240 150
Telefax +46 8 6054 750
info@pfisterer.se
www.pfisterer.se

PFISTERER IXOSIL AG

Gothardstrasse 31
6460 Altdorf
Schweiz
Telefon +41 41 8747 575
Telefax +41 41 8747 576
power@ixosil.ch
www.ixosil.ch

PFISTERER SEFAG AG

Werkstrasse 7
6102 Malters, Luzern
Schweiz
Telefon +41 41 4997 272
Telefax +41 41 4972 269
connect@sefag.ch
www.sefag.ch

PFISTERER UPRESA S.A.U.

Calle Industria 90-92
08025 Barcelona
Spanien
Telefon +34 93 4367409
Telefax +34 93 4367701
pfisterer.upresa@pfistererupresa.eu
www.pfisterer.es

PFISTERER (Pty.) Ltd.

9 Willowton Road
Pietermaritzburg 3201
Südafrika
Telefon +27 33 397 5400
Telefax +27 33 387 6377
info@pfisterer.co.za
www.pfisterer.co.za

PFISTERER

Representative Office
Budova Mediahall
Bidlacky 20
63900 Brünn
Tschechien
Telefon +420 533 337 190
Telefax +420 533 337 191
dialog@pfisterer.cz
www.pfisterer.cz

PFISTERER

Representative Office
Beg u. 3-5
1022 Budapest
Ungarn
Telefon +36 1 2513441
Telefax +36 1 2511713
office@pfisterer.hu
www.pfisterer.hu

PFISTERER

North America Inc.
7625 Wisconsin Avenue
Suite 306
Bethesda, Maryland 20814
USA
Telefon +1 240 482 4955
Telefax +1 240 482 3599
info@pfisterer.us
www.pfisterer.us

PFISTERER

Representative Office
P.O. Box 184090
Hamarain Center
Gate 7, Floor 3, Dubai
Vereinigte Arabische Emirate
Telefon +971 4 2690147
Telefax +971 4 2690148
info@pfisterer.ae
www.pfisterer.ae



THORNE &
DERRICK
INTERNATIONAL

Thorne & Derrick
+44 (0) 191 410 4292
www.powerandcables.com