

Group II Cable Glands

Flameproof, Increased Safety, Dust Protection
Class - Zones - Divisions
Certified ATEX / IECEx

Application

- Outdoor or indoor use.
- For use with single wire armour 'W', wire braid 'X', steel tape armour 'Z', elastomer and plastic insulated cables.
- For particular use with:-
 - Cable inner sheaths that are not effectively filled, compact and/or circular, have tape bedding or have hygroscopic fillers.
 - Cables that exhibit 'Cold Flow' characteristics.
- See technical section for installation rules and regulations

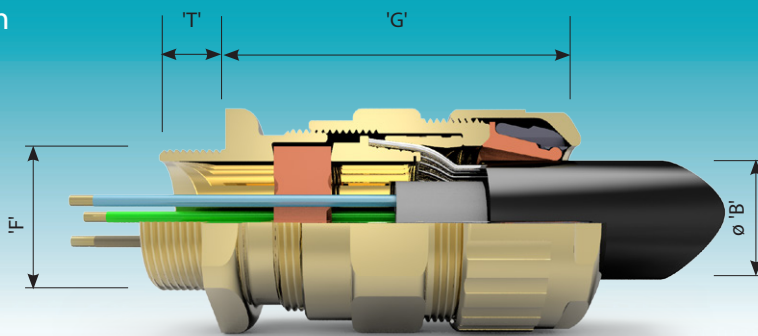

PSG 553/RAC

CABLE GLAND SELECTION TABLE

Size Ref.	Entry Thread Size 'F'		Cable Acceptance Details				'G'	Hexagon Dimensions	
	Metric	NPT * Standard or Option	Outer Sheath 'B'		Armour / Braid 'C'			Across Flats	Across Corners
			Min.	Max.	Orientation 1	Orientation 2			
A	M20	¾" or ½"	12.5	20.5	0.8 / 1.25	0.0 / 0.8	53.0	30.0	32.5
B	M25	1" or ¾"	16.9	26.0	1.25 / 1.6	0.0 / 0.7	69.5	36.0	39.5
C	M32	1¼" or 1"	22.0	33.0	1.6 / 2.0	0.0 / 0.7	64.0	46.0	50.5

'T' — Metric entry threads are 1.5mm pitch as standard, 15mm length of thread.
All dimensions in millimetres (except * where dimensions are in inches).

Technical Data

- Flameproof Exd IIC Gb, Increased Safety Exe IIC Gb and Dust Extb IIIC Db $\text{Ex} \text{IIC} \text{Gb}$
- Certificate No's: Baseefa06ATEX0056X and IECEx BAS 06.0013X.
- Suitable for use in Zone 1, Zone 2, Zone 21, Zone 22 and in Gas Groups IIA, IIB and IIC.
- Construction and Test Standards: IEC/EN 60079-0, IEC/EN 60079-1, IEC/EN 60079-7 and IEC/EN 60079-31.
- Ingress Protection: IP66, IP67 and IP 68* (30 metres for 7 days) to IEC/EN 60529 and NEMA 4X.
- Deluge Protection to DTS01 (Deluge Seal Optional).
- Operating Temperature Range: -60°C to +80°C.
- Assembly Instruction Sheet: AI 312.

* Additional installation procedures required

Features

- Provides a barrier seal to the individual insulated cores within the cable and prevents entry of the products of an explosion into the cable.
- The required number of holes for the cores are punched in the seal by means of a special tool to suit the core size.
- Provides armour clamping using one clamping arrangement for all armour / braid types.
- Provides a cable retention and low smoke and fume, zero halogen seal onto the cables outer sheath.
- Deluge protection option available, contact Hawke Technical Sales for details.
- Manufactured in Brass (standard), Nickel Plated Brass, 316 Stainless Steel or Aluminium.
- Brass NPT entries are nickel plated as standard.

CABLE GLAND SIZE FOR CORE SIZE AND NUMBER

Max. No. of Cores	Cores Cross Sectional Area mm ²				
	1.5	2.5	4.0	6.0	10.0
7	A & B	A & B	B & C	C	C
4	-	-	-	B	-
3	-	-	-	-	B

PUNCH TOOL SIZE DETAILS

Punch Ref.	No. 1	No. 2	No. 3
Cores C.S.A.mm ²	1.5 - 2.5	4.0 - 6.0	10.0

Deluge protection option available.

Ordering Information

To select the correct size punch tool, please see table.
Format for ordering is as follows:

Cable Gland Type	Size	Thread	Material	Punch Tool Required
PSG 553/RAC	C	M32	Brass	Punch Tool No. 1

