

Service Straight -
Side Entry

MECHANICAL CONNECTORS

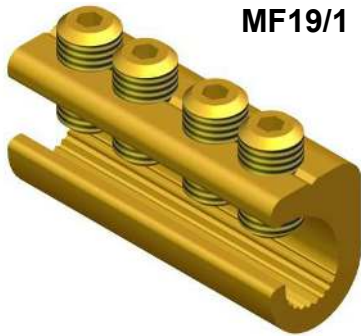

MF19/1 & MF19/1/SHR Connector



MF19/1



MF19/1/SHR

Principle Application:

Stranded and solid circular conductors.

Range:

Product Reference	Type	Core C.S.A. (mm ²)	
		Min	Max
MF19/1 & MF19/1/SHR	Straight Through	4*	35

Note: For jointing other core configurations/sizes please contact Sicame Technical Dept

The **Hepworth MF19/1** mechanical connector is designed for straight connections on stranded or solid cable. The ferrules are manufactured in brass for suitability of jointing both copper and aluminium conductor cores.

The **Hepworth MF19/1/SHR** mechanical connector has a factory fitted lower polypropylene shroud with a 'snap on' upper to fully insulate the assembled connector.

Secondary Application:

Stranded and solid shaped conductors.

Product Reference	Type	Core C.S.A. (mm ²)	
		Min	Max
MF19/1 & MF19/1/SHR	Straight Through	4*	35

Note: For jointing other core configurations/sizes please contact Sicame Technical Dept

Service Straight -
Side Entry

MECHANICAL CONNECTORS

MF19/1 & MF19/1/SHR Connector

Physical Dimensions:

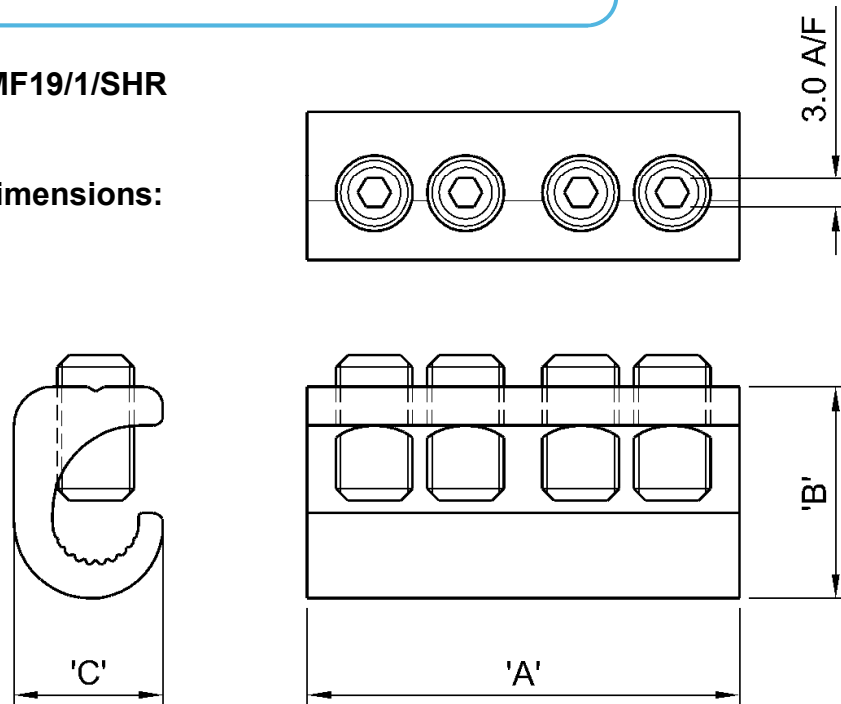

Connector Reference	Dimensions (mm)		
	'A'	'B'	'C'
MF19/1 & MF19/1/SHR	45.0	22.0	15.5

Material:

Body: Copper Alloy (MF19/1 & MF19/1/SHR)

Shroud: Polypropylene

Test Specification:

IEC1238-1: Test Reports TTR/257, 266 and 277

Fitting Instructions:

1. Cut the cables to length and strip the core insulation equal to half the length of the connector +3mm.
2. Thoroughly abrade all conductors to be joined.
3. Align cores within connector and tighten screws on each side of the connector consecutively, until tight.

Note:

*Conductor cores 4mm² and below should be doubled, and if necessary doubled again, to achieve the necessary cross-sectional area.



THORNE &
DERRICK
INTERNATIONAL

Thorne & Derrick
+44 (0) 191 410 4292
www.powerandcables.com