

Straight-through  
mechanical ferrule

## MECHANICAL CONNECTORS

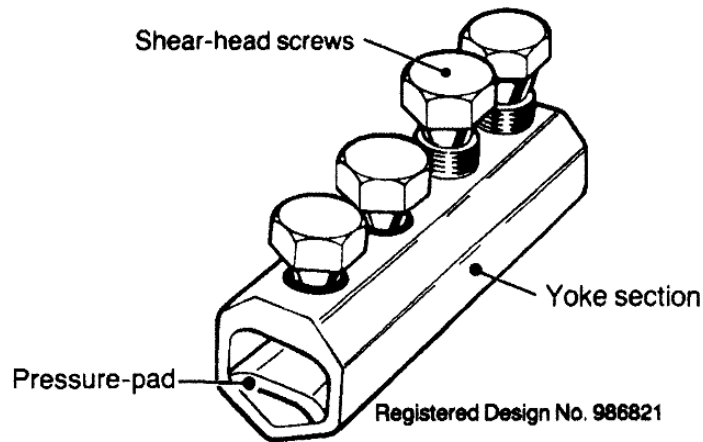

### MF3 Connector



### Principle Application

Solid or stranded 3 & 4 core conductors fitted in either orientation

### Range

| Connector reference | Core c.s.a. (mm <sup>2</sup> ) |      | Approx Unit Wt. (gms) |
|---------------------|--------------------------------|------|-----------------------|
|                     | min.                           | max. |                       |
| MF3/1               | 50                             | 95   | 100                   |
| MF3/2               | 95                             | 185  | 160                   |
| MF3/3               | 185                            | 300  | 275                   |

The Hepworth mechanical ferrule for straight-through joints is designed as an alternative to the traditional sweated or compression ferrule in applications up to 11kV.

Fitting is relatively simple and specialised tools are not required. The connectors can be used with confidence where the sweating method of jointing is either unfeasible or uneconomic. Another important advantage is the suitability of the mechanical ferrule for jointing situations where the use of naked flames or other heating methods are prohibited e.g. mining or petrol-chemical locations. The completed connection on each conductor has a smooth profile and assists in the formation of a compact joint.

Each connector is supplied complete in a sealed pack together with fitting instructions. Further details of fitting procedures are included in the technical details overleaf.

### Extended Applications

In situations involving the jointing of unequal cores where the lower limit of the range of the most suitable connector tabled above is exceeded, modified components can be made available to accommodate the smaller conductor. It is recommended that this procedure is in the first instance discussed with Sicame Electrical Developments so that a satisfactory specification can be agreed.

Straight-through  
mechanical ferrule

## MECHANICAL CONNECTORS

### MF3 Connector

#### Physical Dimensions

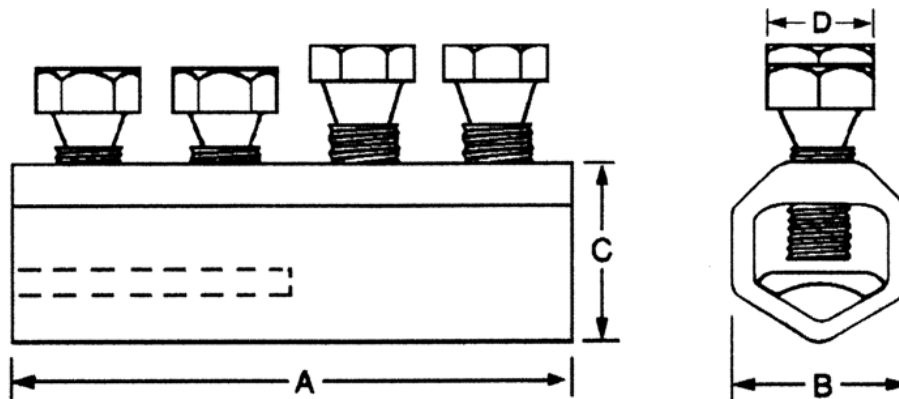

| Ref. Code | Dimensions (mm) |      |      |      |
|-----------|-----------------|------|------|------|
|           | A               | B    | C    | D    |
| MF3/1     | 80.0            | 25.0 | 25.0 | 13.0 |
| MF3/2     | 100.0           | 34.0 | 32.5 | 17.0 |
| MF3/3     | 120.0           | 40.0 | 41.0 | 17.0 |

#### Material

HE 30 TF Aluminium Alloy

#### Fitting instructions

Cut the cores to length, strip the insulation from each core equal to the length of a pressure pad plus 6 mm and thoroughly abrade the exposed conductors. Loosen the screws, and fit the connector over one of the cores, where possible sliding the full length of the barrel back over the insulation. Ensure that the longer screws are located with the solid conductor. Align the cores and slide the connector back over both conductors until centrally located. Insert the pressure pad over the stranded conductor and tighten the screws consecutively, one turn at a time until the heads are sheared from all four screws.

NOTE: Copper conductors must be wrapped in brass gauze to improve the electrical stability of the connection.



THORNE &  
DERRICK  
INTERNATIONAL

Thorne & Derrick  
+44 (0) 191 410 4292  
www.powerandcables.com