

CAUTION : Read instructions thoroughly and completely prior to beginning installation.

### Installation instructions for separable tee connector - type C interface

**EUROMOLD®**











**(K),(M),(P)440TB/G**  
Up to 20.8/36 (42) kV

Only to be used on copper wire screened cable with extruded easy strip or bonded semi-conductive screen (Part A) or fabric tape screen (Part B).



Check if the diameter over cable core insulation is in accordance with the cable reducer range as indicated in table below:

Cable reducer size (see label on cable reducer)	Dia. over core insulation (mm)	
	min	max
611CA-15	16.0	22.0
611CA-19	20.0	26.5
611CA-22	23.5	31.0
611CA-27	28.5	37.5
611CA-32	34.0	42.5
611CA-37	39.0	48.5
611CA-43	45.5	56.0

**Required components for the connector installation :**

 <p>Tee connector housing 440BT/G</p>	 <p>Cable reducer 611CA-W</p>	 <p>Clamping screw - 400TCS</p>	 <p>1 x Conductor contact - TBC-X or TMBC-X Installation instructions</p>
 <p>Field control mastic, type MFC-RLT</p>	 <p>Silicone grease + wipers</p>	 <p>Gloves</p>	 <p>Roll adhesive tape 1 x Basic insulating plug + cap - 400BIPA</p>
 <p>Installation instructions</p>			

**Further required components depending on application and cable type (optional supply) :**

 <p>Water sealing mastic, type MWS For outdoor applications only.</p>	 <p>Semi-conductive tape, type TSC, for fabric tape screened cable only</p>
--	--

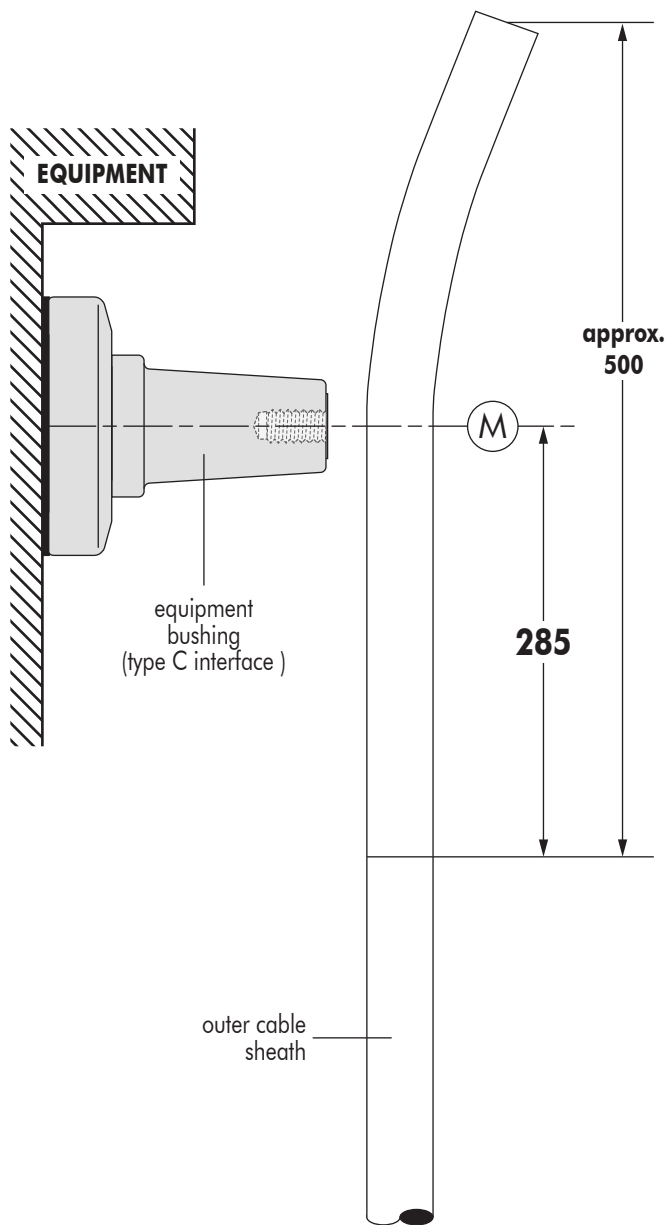

- 1 Train the cable into the approximate finished position next to the equipment bushing.
- 2 Remove the outer cable sheath to a point **285** mm from the centre line « **M** » of the bushing.

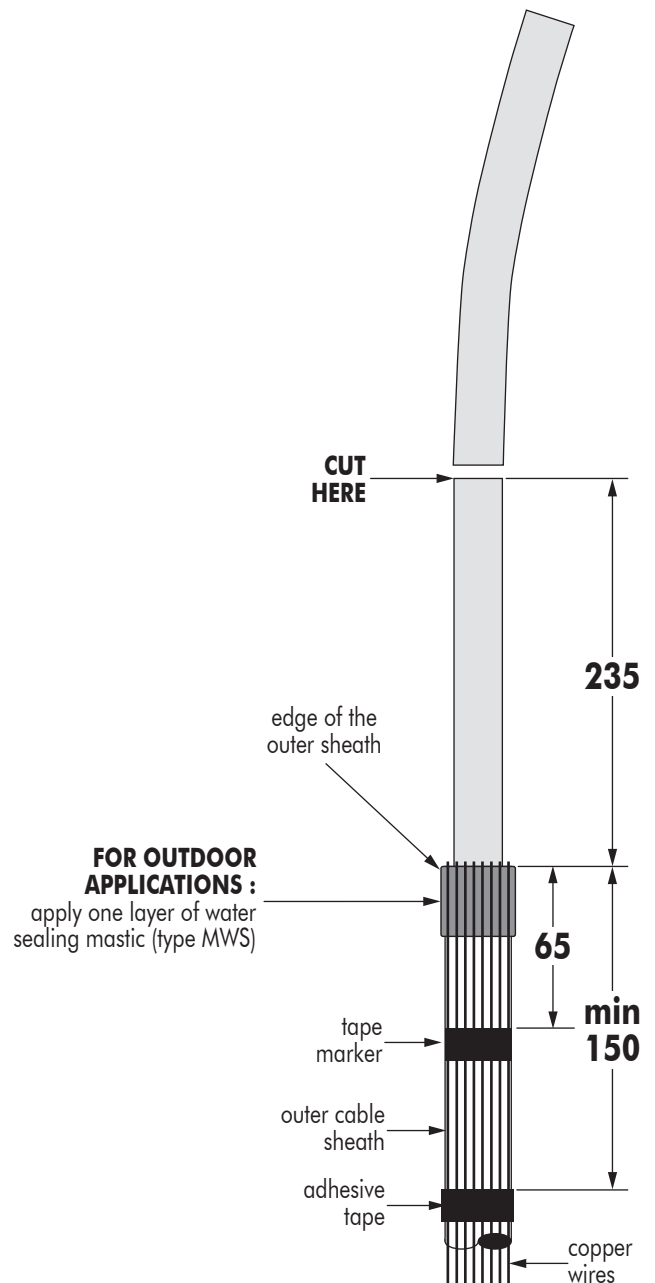

- 3 Apply a tape marker around the outer sheath **65** mm from the edge. For indoor applications, bend the screen wires back over the outer sheath and proceed to step no. 4.

#### **For outdoor applications :**

- Wrap one layer of water sealing mastic (type MWS) around the outer sheath, flush with the end (**25** mm minimum width). Completely encircle the cable.
- Bend the screen wires back over the mastic and along the outer sheath, pressing them into the mastic.

**IMPORTANT :** screen wires should not touch each other when pressed into the mastic to prevent water ingress.

- 4 Using adhesive tape, fix the screen wires at a distance of min **150** mm from the edge of the outer sheath.
- 5 Cut the cable to a point **235** mm from the outer sheath.

## CABLE PREPARATION

**A**

Copper wire screened cable with extruded semi-conductive screen

For extruded easy strip semi-conductive screen

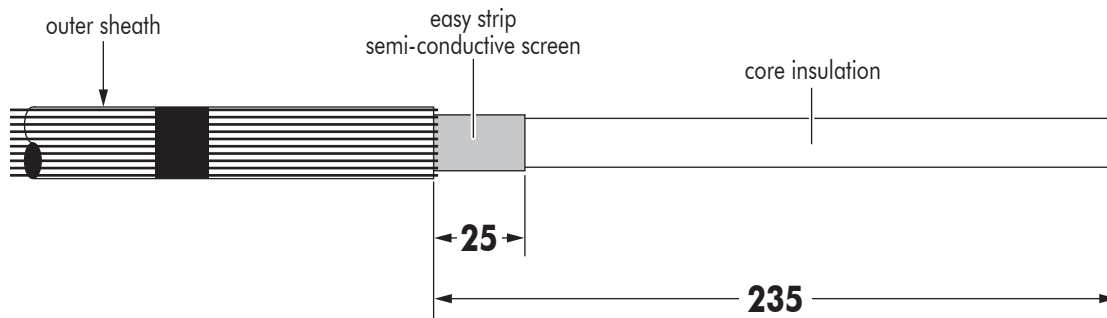

- 1 Check distance of **235** mm.
- 2 Remove the easy strip semi-conductive screen to a point **25** mm from the outer sheath. Cut squarely taking care not to cut the core insulation.

For bonded extruded semi-conductive screen

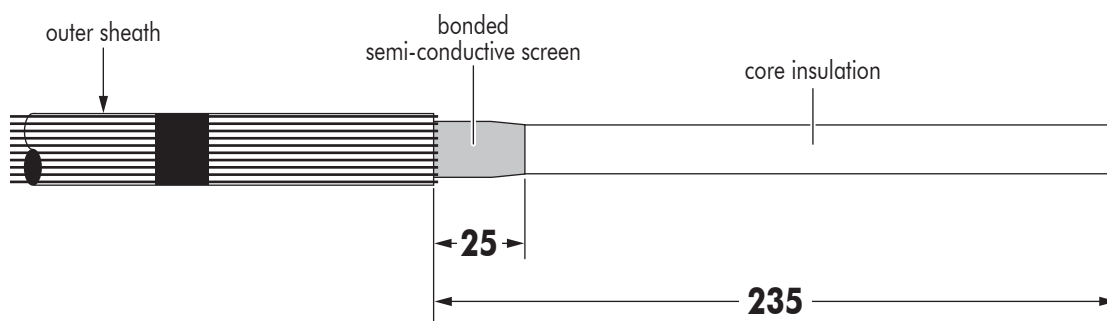

- 1 Check distance of **235** mm.
- 2 Remove the bonded semi-conductive screen to a point **25** mm from the outer sheath. Use an appropriate pencilling tool.
- 3 **Remove any traces of conductive residue from the core insulation.**

**PROCEED ON PAGE 5 FOR THE INSTALLATION OF THE CABLE REDUCER**

## B

## Copper wire screened cable with fabric tape screen

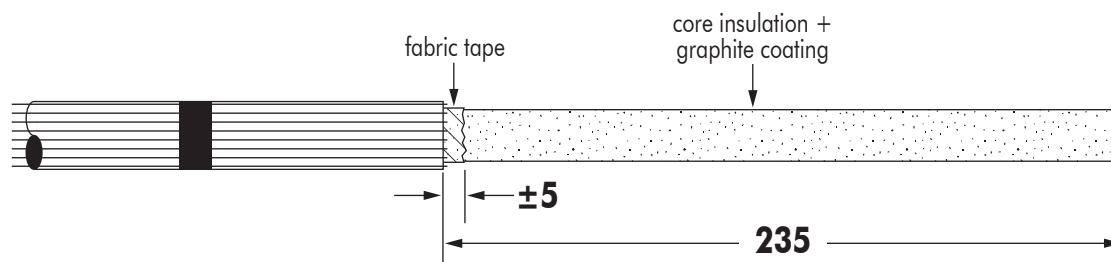

- 1 Check distance of **235** mm.
- 2 Remove the fabric tape to a point approx. **5** mm from the outer sheath.  
**Do not remove the graphite varnish at this stage.**

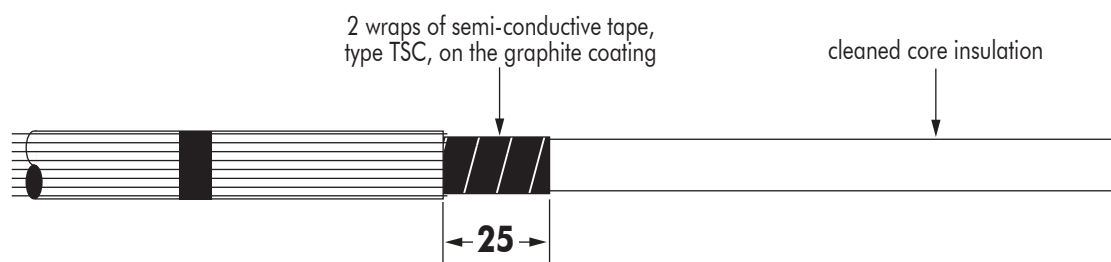

- 3 Apply 2 wraps of semi-conductive tape, type TSC, on the graphite coating up to a point of **25** mm from the outer sheath.
- 4 **Using an appropriate solvent thoroughly remove the graphite coating up to the semi-conductive tape.**

## REMOVAL OF THE CORE INSULATION

### A. Compression type contacts (Type TBC-X)

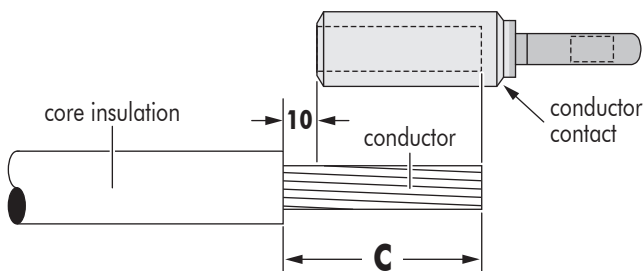

### B. Mechanical type contacts (Type TMBC-X)

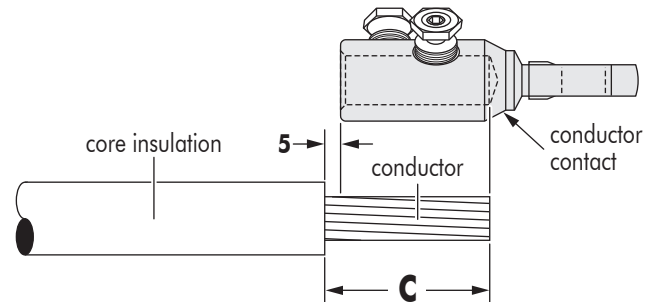

- 1 A. For compression type contacts :** remove the core insulation from the conductor for a distance « **C** » mm (**C** = depth of contact bore + **10** mm).
- 1 B. For mechanical type contacts :** remove the core insulation from the conductor for a distance « **C** » mm (**C** = depth of contact bore + **5** mm).

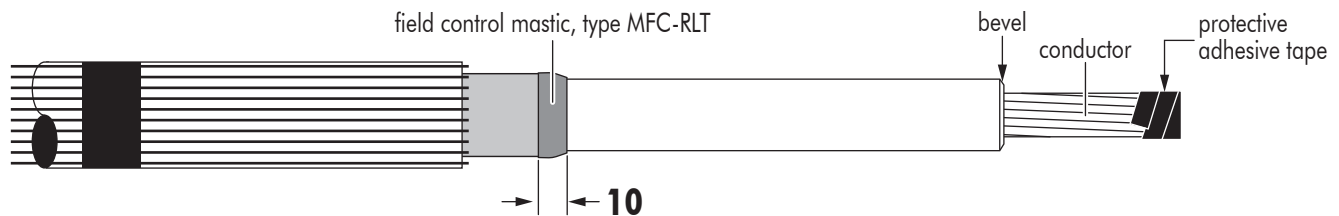

- 2** Slightly bevel the edge of the core insulation.
- 3 Thoroughly clean core insulation.** Always wipe towards the screen wires.
- 4** As a protection, wrap a few turns of adhesive tape around the conductor end.
- 5** Remove field control mastic strip, type MFC, from coated paper.
- 6** Slightly stretch one end of the strip, making sure not to break it.
- 7** Apply the mastic on the cutback edge of the semi-conductive screen, covering approximately **5** mm of the extruded semi-conductive screen and **5** mm of the core insulation.
- 8** Push the mastic in place while stretching it progressively until both ends overlap and tear-off the excess mastic.
- 9** Using the coated side of the paper, squeeze the mastic tightly in place on the step of the semi-conductive screen.

## INSTALLATION OF THE CABLE REDUCER

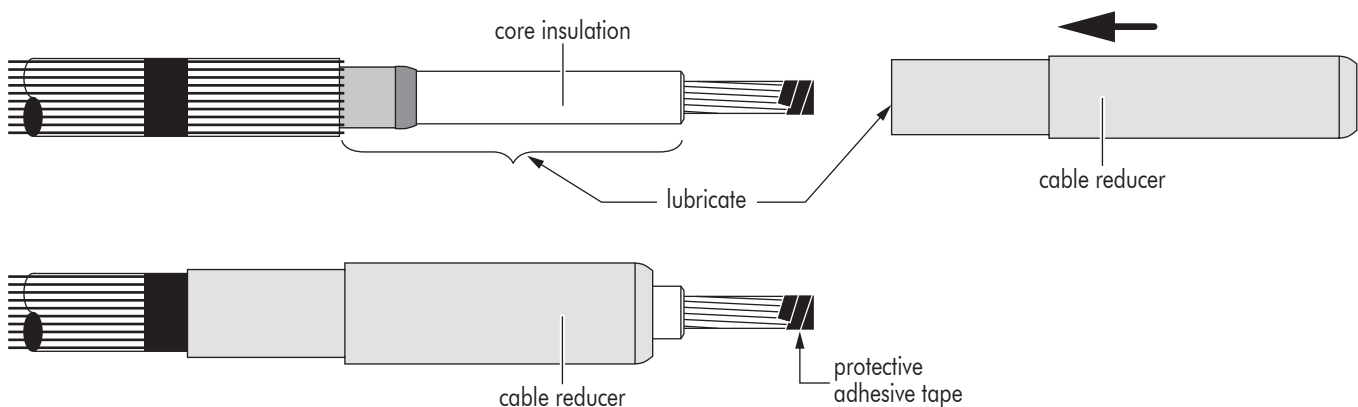

- 1** Lubricate\* the indicated area : core insulation, mastic, semi-conductive screen and inner surface of the reducer.
- 2** Slide the reducer down the cable.
- 3** Remove protective adhesive tape from the conductor.

\* USE ONLY THE SILICONE LUBRICANT SUPPLIED

## CRIMPING/TIGHTENING OF THE CONTACT

# A

### Compression type contacts (Type TBC-X)

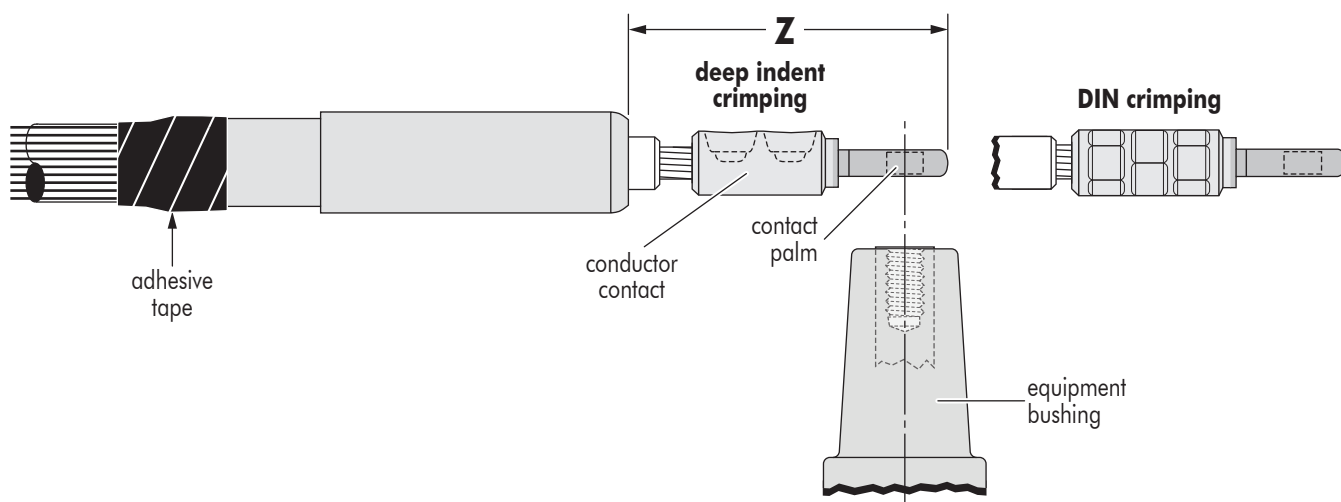

- 1 For aluminium conductors : before installing the conductor contact, wire brush the conductor.
- 2 Fit the contact on to the conductor.
- 3 Position the crimp contact taking care that the contact hole aligns with the bushing hole.
- 4 Prior to crimping distance « Z » must be between **155** and **160** mm.
- 5 Crimp the contact. Please refer to the crimp chart for crimp sequence.
- 6 After crimping distance « Z » must be between **155** and **165** mm.  
If necessary, adjust the position of the cable reducer until distance « Z » is within the tolerance range.  
Using adhesive tape, secure the cable reducer.
- 7 **Remove any burrs left after crimping and wipe-off excess inhibitor.**

## B

## Mechanical type contacts (Type TMBC-X)

## Before tightening

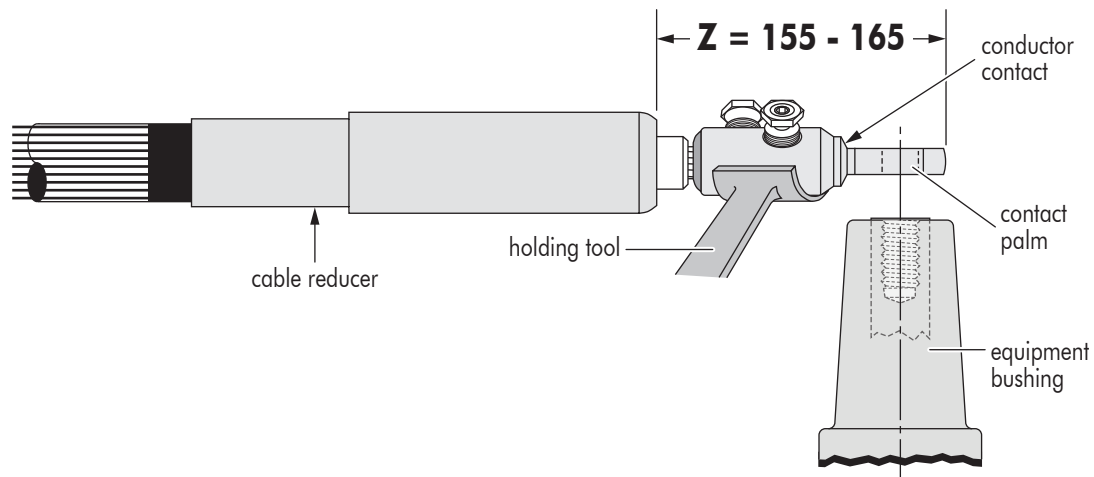

- 1 For aluminium conductors : before installing the conductor contact, wire brush the conductor.
- 2 Insert, if necessary, the centre ring into the contact barrel according to the table in the contact installation instruction.
- 3 Position the contact taking care that the contact hole aligns with the bushing hole. **The contact must align with the bushing in order to avoid any undue pressure on the bushing or the connector.**
- 4 Before tightening, distance « Z » must be between **155** and **165** mm.
- 5 Tighten the contact. Please refer to the installation instruction included with the contact.

## After tightening

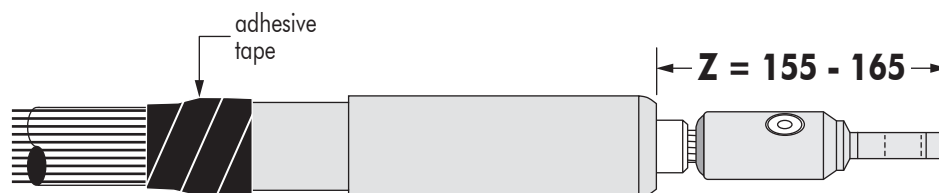

- 6 After tightening, distance « Z » must be between **155** and **165** mm.  
If necessary, adjust the position of the cable reducer until distance « Z » is within the tolerance range.  
Using adhesive tape, secure the cable reducer.



## CONNECTOR INSTALLATION ON CABLE

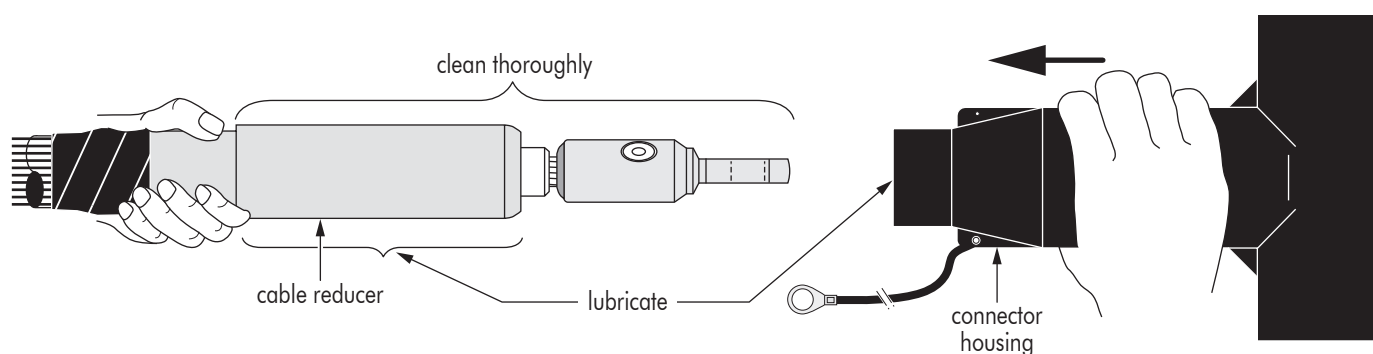

- 1 Clean and lightly lubricate\* the inside surface of the connector housing and outer surface of the cable reducer.
- 2 Check if the angle of the tee connector housing is correct relative to the palm of the crimp contact and, whilst preventing the cable reducer from further movement down the cable, gently slide the housing on the cable until it cannot advance any further.
- 3 Make sure the cable reducer stays in place during installation and remove tape marker from the cable.

## CONNECTOR INSTALLATION ON BUSHING

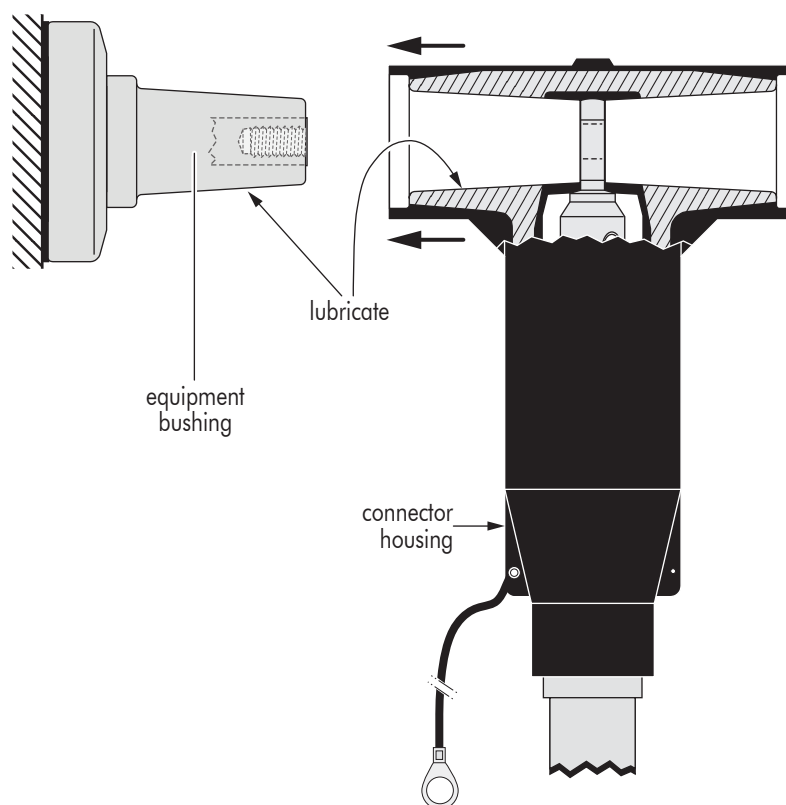

- 1 Clean and lightly lubricate\* both connector and bushing interface.
  - 2 Push connector on to the bushing.
- In order to achieve the correct applied torque ensure that there is no lubricant on the threaded parts.**

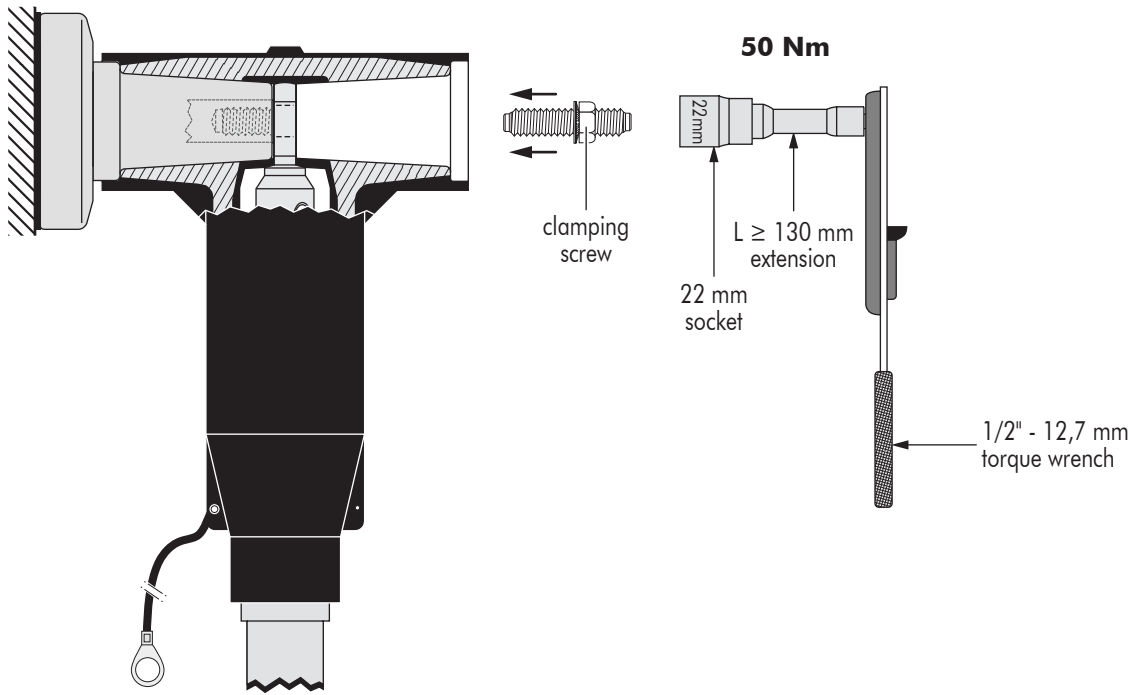

- 3** Insert clamping screw into the threaded hole of the bushing **by hand**.
- 4** Use torque wrench with a socket wrench 22 and tighten exerting **50 Nm** (5 kgm or 36,9 foot-pounds) of torque **In order to achieve the correct applied torque ensure that there is no lubricant on the threaded parts.**

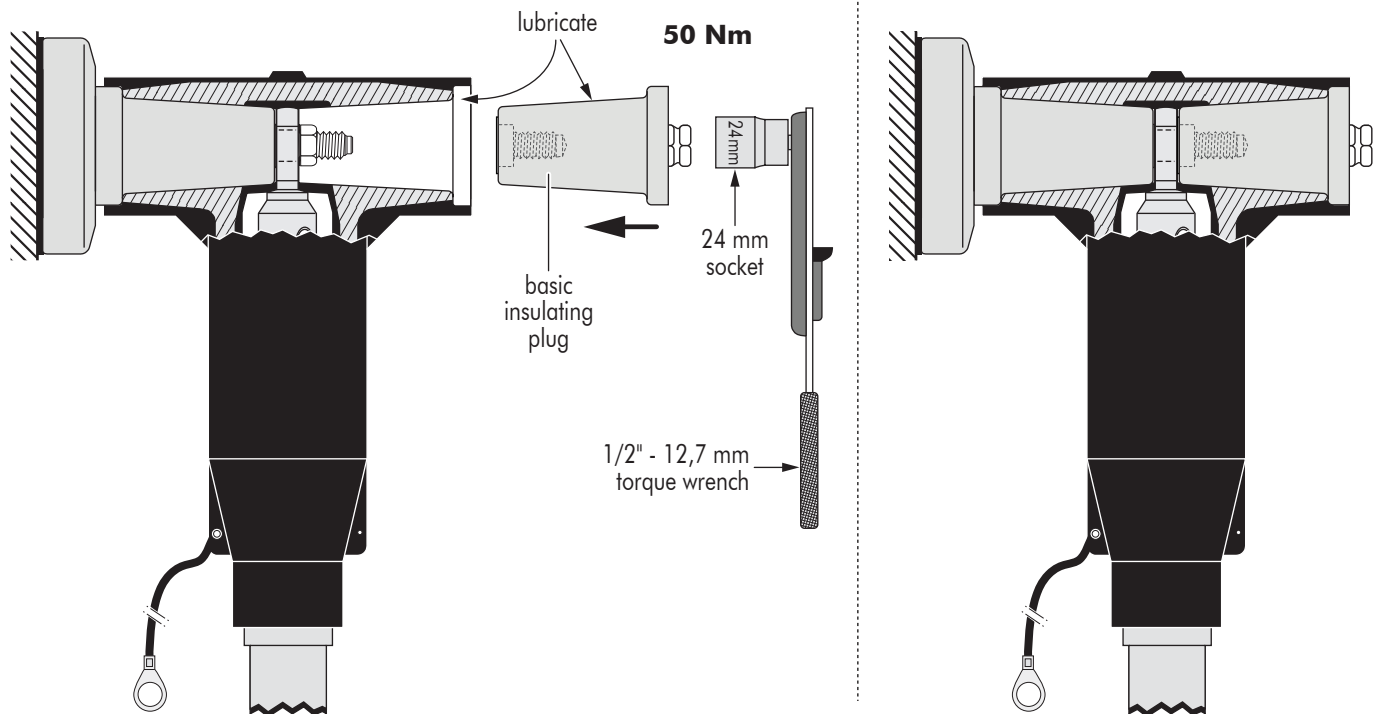

- 5** Clean and lubricate\* the insulating plug for the opposite side of the connector.
- 6** Insert the plug in the connector and tighten assembly : use torque wrench with socket of 24 and tighten exerting **50 Nm** of torque. **In order to achieve the correct applied torque ensure that there is no lubricant on the threaded parts.**

## INSTALLATION OF THE CAP

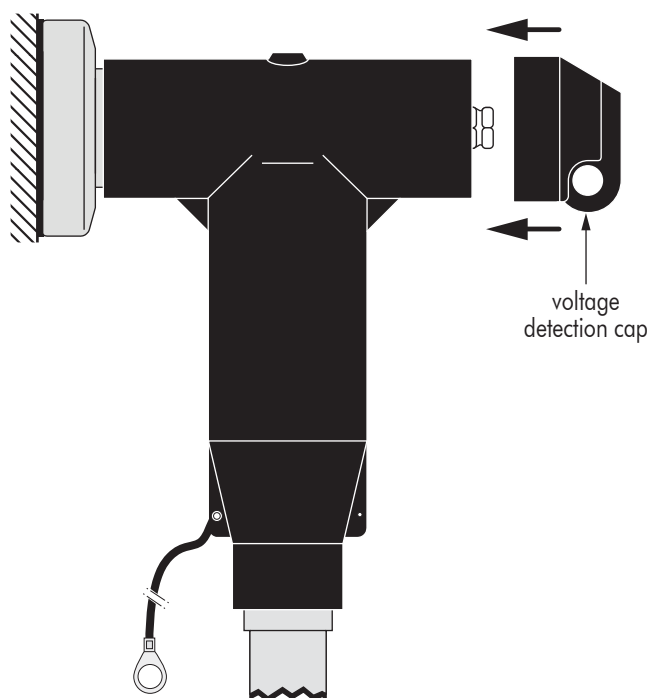

- 7** Clean inner surface of voltage detection cap (do not lubricate) and place on the connector. Push down hard until cap "snaps" into place.

### NOTE :

**A connector/bushing mated combination should not be allowed to carry the full weight of the cable. Therefore it is necessary to clamp the cable as close as possible to the connector.**

## CONNECTOR EARTHING AND CABLE CLAMPING

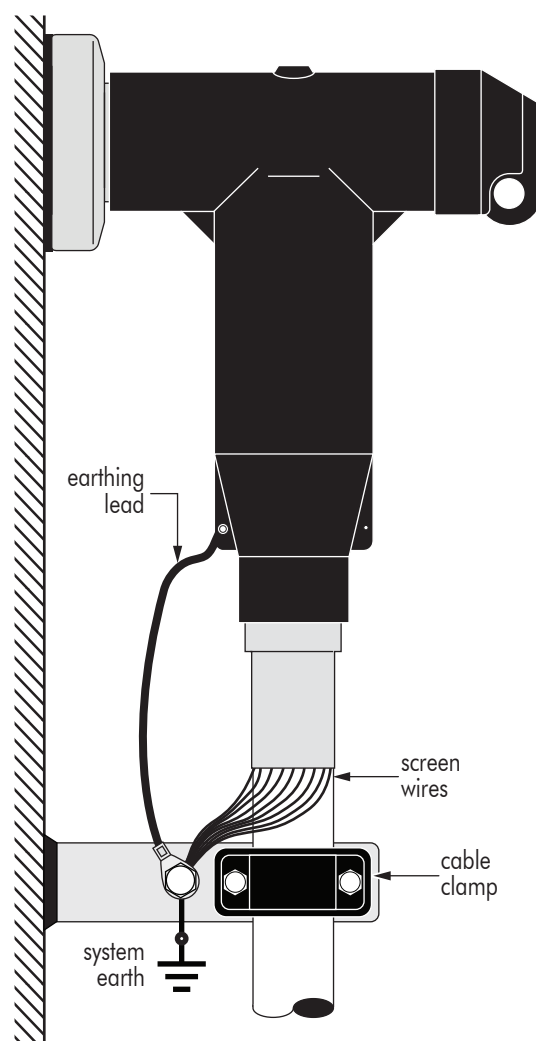

- 1** Bend back the screen wires along the outer sheath to form a pig tail.
- 2** Connect the earthing lead and screen wires to the system earth.

### IMPORTANT NOTES :

- **Never disconnect the connector from energised equipment nor energise a disconnected connector without previously installing on its appropriate corresponding mating part.**
- **Do not allow hydrocarbon oils or solvents to contaminate the E.P.D.M. rubber. In the event of contamination, wipe the surface clean with a dry cloth.**