

# SLIPSIL WATERSTOP

For use with RISE Duct & NOFIRNO Sealing Systems in running water applications



It is essential when installing the RISE and NOFIRNO Duct Seal systems that the ducts or building entries are dry and that water pressure does not build up behind the seal which could cause failure during curing of the sealant layer. Using the SLIPSIL technology of Beele Engineering we have adapted the standard SLIPSIL plug to include a drain assembly that allows for installation of our duct seal systems in certain wet conditions. Once the sealant layer has fully cured the drain can be capped to complete the seal.

## Installation layout.

Onshore application.

### TOOLS REQUIRED

- Wooden depth gauge (marked at 80mm)
- Dead blow hammer (16oz)

Duct size (Internal diameter)	SLIPSIL Waterstop
99mm to 101mm	100/WS
149mm to 151mm	150/WS

Other sizes are available, please consult CSD with your requirement.

Fig. 1

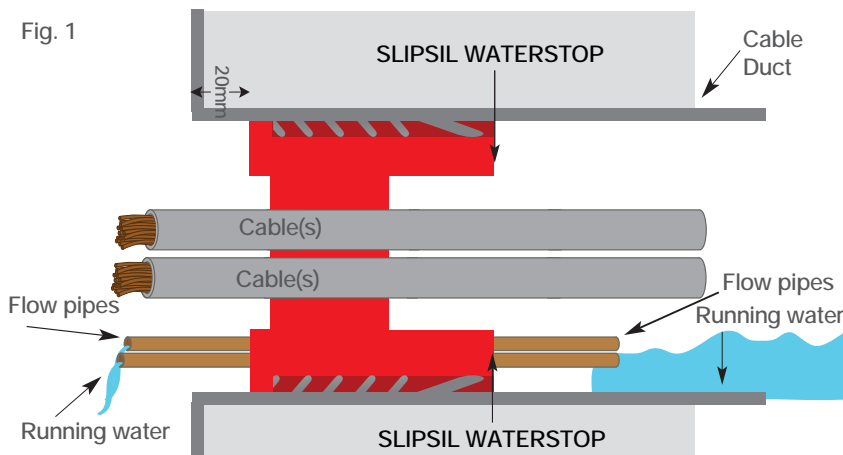
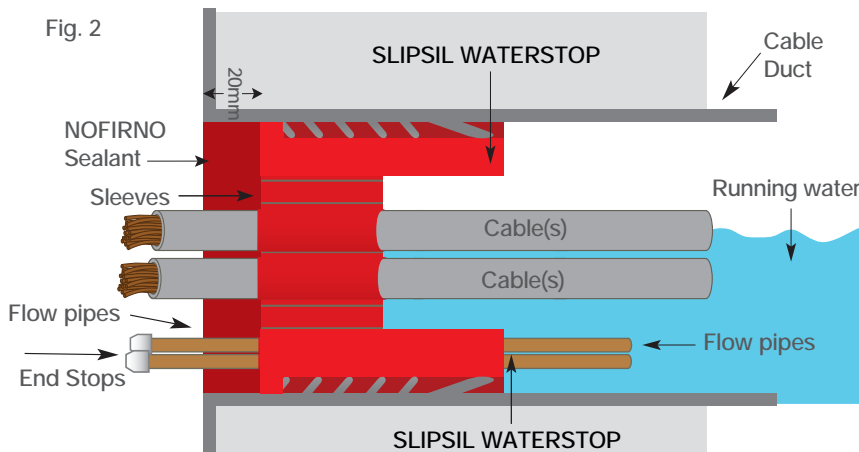

Fig. 2



THORNE &  
DERRICK  
INTERNATIONAL

Thorne & Derrick  
+44 (0) 191 410 4292  
www.powerandcables.com

# Split & Modular Frames for duct entries

Split, modular & top hat frames for fixation against the wall/floor fill frame(s).

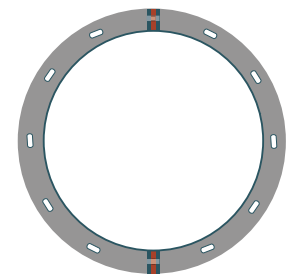
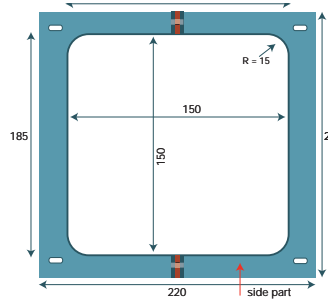
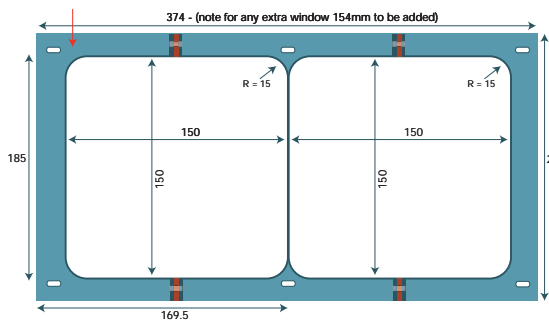
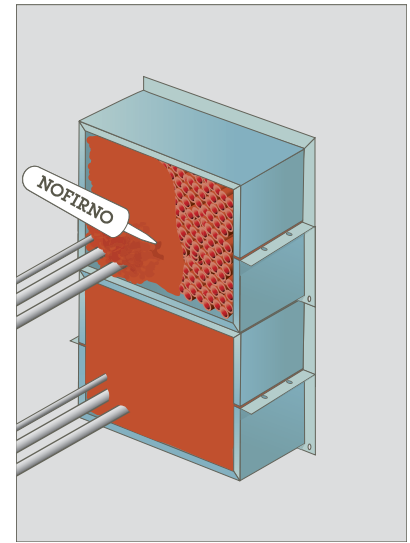
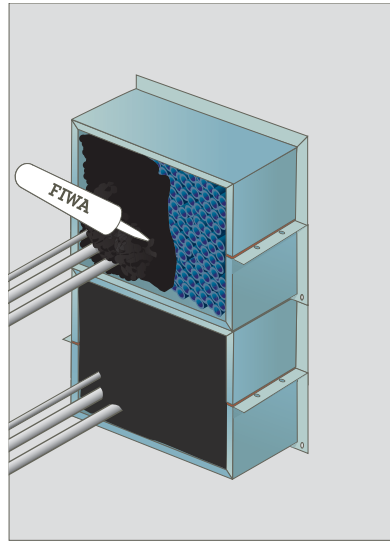
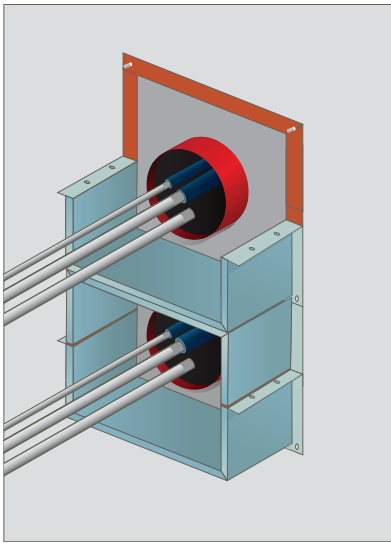

Standard size for 100mm, 150mm ducts  
Size can be modified to suit any application.

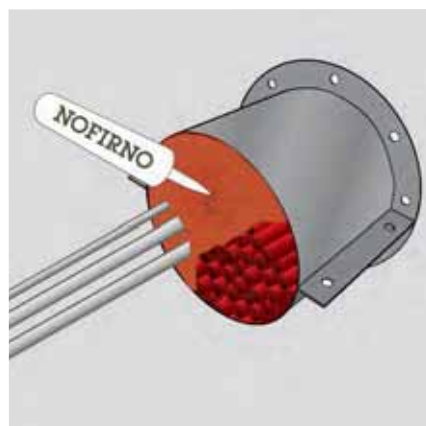
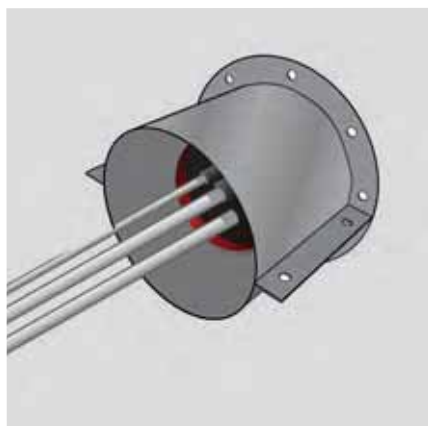

## Gas and water tight

In many instances, it may be impossible to remove the leaking penetration seal through which cables or pipes have been ducted. For this purpose, the CSD split frames have been developed. The sections of the frame can be placed around the ducted cables/pipes and connected to each other by placing a NOFIRNO gasket between the flanges and bolted together. The frame is then fixed to the wall with a NOFIRNO split gasket between the frame and the wall. With the developed intermediate parts, multi-frames can be assembled to larger sizes.



After the frame has been installed, the RISE Duct sealing system can be applied. The depth of the frames is 80mm which accommodates 60mm insert and filler sleeves. The remaining 20mm is used for applying a 20mm layer of sealant.

# SLIPSIL SEALING PLUGS

Water and gastight for empty or single service building entry and cable ducts

SLIPSIL Sealing Plugs combine fast and simple installation with effective sealing performance against the risks from flooding or gas ingress. Designed for best use in empty or single service building entry or cable duct ends. The SLIPSIL plug can also be used to seal in running water conditions. It is essential that the duct is circular and the internal diameter is within the sealing tolerance of the sealing plug (-1mm/+0.7mm). For applications with multiple cables or where re-entry for adding, removing or replacing cables is required our NOFIRNO Duct Seal system will offer a better solution.



## Installation layout.

Onshore application.

For water and gastight sealing

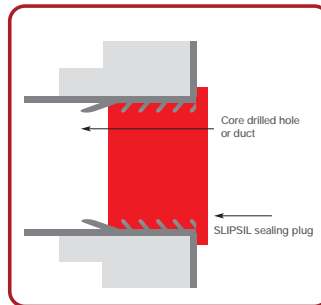

### TOOLS REQUIRED

- CSD approved lubricant
- Wooden block
- Dead blow hammer (16oz)
- Thin slotted screwdriver

### SLIPSIL PLUG SELECTION FOR EMPTY DUCTS

50MM DUCT	SLIPSIL50/0
100MM DUCT	SLIPSIL100/0
125MM DUCT	SLIPSIL125/0
150MM DUCT	SLIPSIL150/0
152MM DUCT	SLIPSIL152/0
154MM DUCT	SLIPSIL154/0
200MM DUCT	SLIPSIL200/0



#### Step 1

Select the correct size SLIPSIL sealing plug, ensure that the duct is circular and within the tolerance of the SLIPSIL plug. The duct should be free from any obstruction or debris which could interfere with the SLIPSIL plug installation.

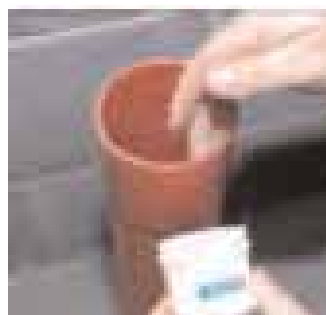

#### Step 2

Apply CSD lubricant to the inside surface of the cable duct. Lubricate to a depth which corresponds with the length of the SLIPSIL plug to be installed.



#### Step 3

Apply the CSD lubricant to the inside surfaces on all segments of the SLIPSIL plug.



#### Step 4

Now apply the lubricant to the outside surfaces.

# Installation Instructions.



## Step 5

Insert the SLIPSIL plug equally in to the duct. Insert to the level of the first set of serrations.



## Step 6

Applying even pressure, push the SLIPSIL plug further into the plastic cable duct, at this stage do not push the SLIPSIL plug all the way in.



## Step 7

Continue to apply even pressure until the plug is inserted to the final serration.



## Step 8

Finish inserting plug into the duct ensuring that all surfaces of the SLIPSIL plug are flush with the end of the duct.



## Step 9

It is advisable at this stage to release pressure from inside the duct. This will make final installation easier by removing compressed air from within the sealed duct. Lubricate the tip of a slotted screwdriver and insert between the segments of the plug until the pressure is released.



## Additional Step

If additional force is required, a wooden block and a rubber mallet can be used to fully insert the SLIPSIL plug into the plastic duct.



## Step 10

The completed SLIPSIL plug when installed into the duct will provide a 1.5 bar (22 psi) watertight and 1.0 bar (15psi) gastight rated seal.

# SLIPSIL<sup>®</sup>

Seals for Cable and Pipe Entries.

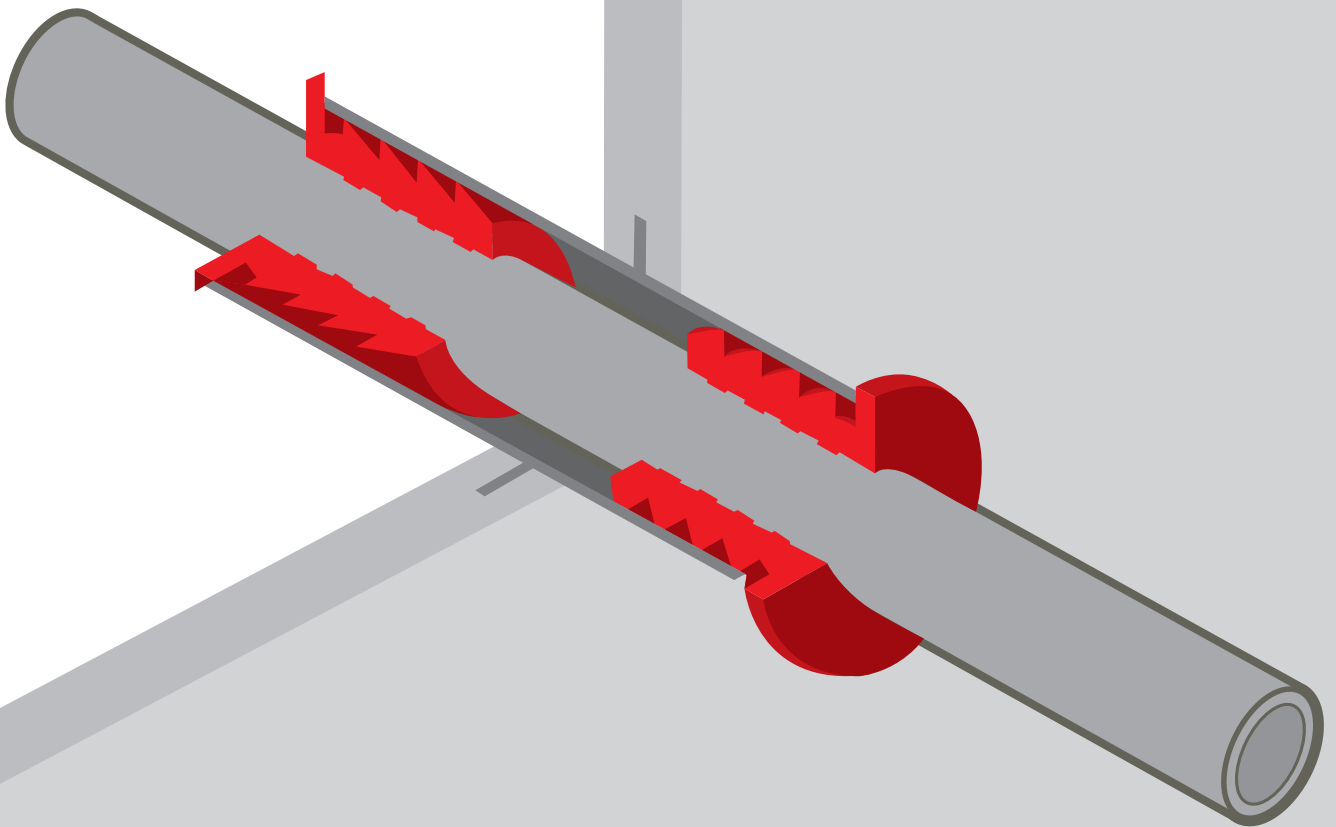

*“CSD Sealing Plugs consist of two equal parts that allows them to be inserted after all pipes or cables in a conduit are installed.”*

# Features.



## **New generation seals**

SLIPSIL is the new generation sealing plug from CSD. It combines simple installation with effective sealing performance. It is designed to seal pipes and cables against the ingress of fire, gas and water at pressures in excess of 2.5 bar, and is resistant against fire for up to 2 hours. In a range of sizes to suit services between 5mm and 520mm in diameter, the plug will cope with a much larger tolerance than the traditional CSD Sealing Plugs.

## **Simple installation, outstanding performance**

CSD Sealing Plugs consist of two equal parts that allows them to be inserted after all pipes or cables in a conduit are installed.

The flange of the sealing plug prevents the plug being inserted too far and is labelled with size information to ease identification and inspection. The profiling of the sealing plug makes it easy to push into the opening, but will create an extremely effective long-term seal with guaranteed performance.



# Benefits.



*“Fast  
and simple  
to install.”*

## *Can be installed in minutes*

Allows the shortest possible conduit length for fire rated penetrations

Can be used for all types of metallic and plastic pipes

Does not require bolting or any other mechanical outfitting

Low maintenance

Can be exposed to high pressure loads directly after installation

Tested under severe conditions, suitable for wide ranging industries and for use in the harshest environments

# Extensive pressure testing.



SLIPSIL sealing plugs have undergone through three pressure tests at nominal dimensions to determine the pressure ratings for plugs with smallest, medium and largest of openings.

Each plug size is then also pressure tested at each of the possible tolerance limits from the largest allowable conduit dimension with the smallest allowable service pipe dimension, through to the opposite limits.

This creates a total of twelve pressure tests for each series to determine the operational tolerances and ease of installation.

Lloyds Register Witnessed  
– 2.5 bar pressure test

TNO Laboratory – Age Testing to 50 years

BSEN1366-3 European Fire Test  
– 2 hour fire protection

NES711 – Low Smoke Index

NES713 – Low Toxicity Index

ISO 4589-3 – High Temperature Index

ISO 4589-2 – High Oxygen Index



# Innovative technology.

Seal fitted either side to correspond to service OD and conduit ID

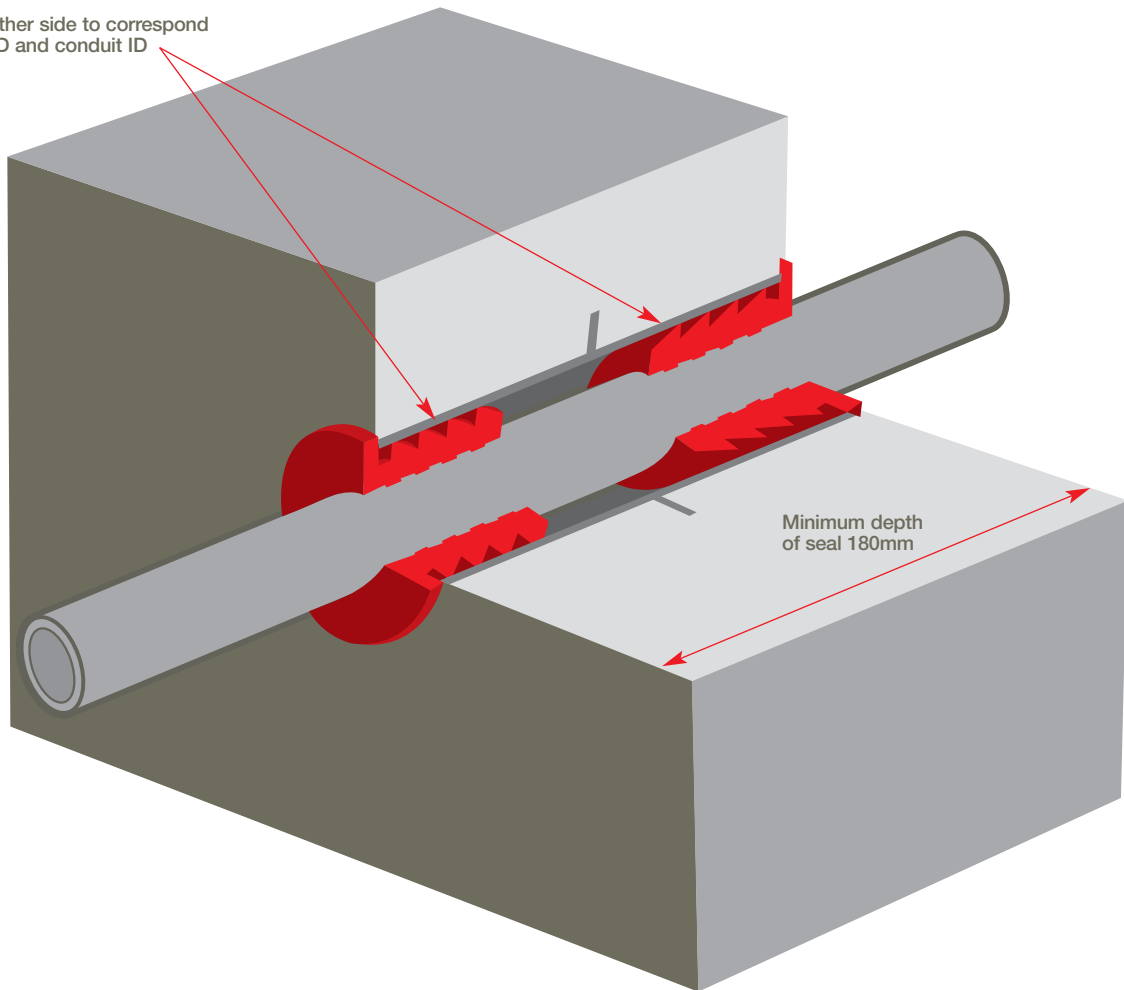

Test standards	Fire resistance integrity	Fire resistance insulation
BSEN1366-3	2 hrs	2 hrs
BSEN13501-2:2003	2 hrs	2 hrs

Specialist conduit frames are available. Alternatively, SLIPSIL plugs can be inserted into core drilled holes.

# Installation.



## Step 1

Before starting the installation, any dirt or oil residues should be removed from the conduit opening.



## Step 2

The inside wall should then be treated with CSD lubricant along a distance which approximately corresponds with the length of the sealing plug.



## Step 3

The inside surfaces of both segments of the sealing plug need to then be covered with CSD lubricant.

# ...continued.



## Step 4

The segments of the sealing plug need to be treated with CSD lubricant on the outside. Ensure all surfaces are well lubricated.



## Step 5

Place both segments of the sealing plug around the ducted pipe and then push into the conduit opening as far as the first serration.



## Step 6

Push both segments of the sealing plug evenly by hand, serration by serration, further into the conduit opening. For some plugs at extreme tolerance, a wooden section and mallet may be required.



## Step 7

To satisfy certification requirements a plug should be installed at each end of the penetration (flanged edge flush against the frame). When installing the second plug, air can become trapped inside the penetration. Use a lubricated screwdriver, carefully insert the end between the 2 plug segments to release the air. Repeat process if required until all air is released and the second plug is fully inserted.

## Plastic pipes (additional steps)

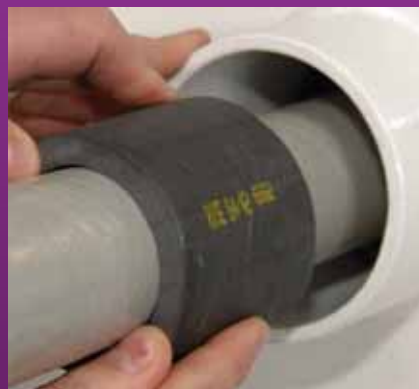

## Step 8

For plastic pipes, you must use an 80mm wide wrap of RISE FRR/EHF rubber between the SLIPSIL plugs. A pre-formed sleeve can be used for pipe sizes up to 44mm and wrap in 1m or 3m lengths for sizes above.



## Step 9

Once the wrap is inserted in to the centre of the penetration, the second SLIPSIL plug can be installed as before. This will create a fully certified plastic pipe SLIPSIL penetration.

# SLIPSIL selection table for metallic and GRP pipework.

STEP 1			STEP 2						
BS (NB)	ASTM (NB)	MM	SERIES 35 (Suits 5-20mm)	SERIES 53 (Suits 10-34mm)	SERIES 78 (Suits 22-50mm)	SERIES 103 (Suits 40-75mm)	SERIES 128 (Suits 60-92mm)	SERIES 154 (Suits 88-125mm)	SERIES 207 (Suits 110-168mm)
		6	35/5-6						
		8	35/8-9						
		10	35/10-12	53/10-12					
		12	35/12-14	53/12-14					
1/4"	1/4"	13	35/12-14	53/12-14					
		15	35/14-16	53/14-16					
3/8"	3/8"	17	35/16-18	53/16-18					
		18	35/18-20	53/18-20					
		20		53/20-22					
		21		53/20-22					
		22		53/22/-24					
		25		53/24-26					
3/4"	3/4"	26		53/26-28					
		28		53/28-30	78/28-30				
		30		53/30-31	78/30-32				
1"	1"	33		53/33-34	78/32-34				
		35			78/34-36				
		38			78/38-40				
		40			78/40-42				
1 1/4"	1 1/4"	42			78/42-44	103/42-44			
		44			78/44-46	103/44-46			
1 1/2"	1 1/2"	48			78/48-50	103/48-50			
		50			78/50	103/50-52			
		53				103/52-54			
		54				103/54-56			
2"	2"	60				103/60-62	128/60-62		
		63				103/62-63	128/62-64		
		67				103/66-68	128/66-68		
	2 1/2"	73				103/72-74	128/72-74		
2 1/2"		76					128/76-78		
3"	3"	88					128/88-90	154/88-90	
		108						154/108-110	
4"	4"	114						154/114-116	
6"	6"	168							207/168

STEP 3							
NB	1 1/4"	2"	3"	4"	5"	6"	8"
OD & Wall Thickness (mm)	42.2 x 3.56	60.3 x 3.6	88.9 x 5.49	114.3 x 5.6	139.7 x 5.6	168.3 x 7.11	219.1 x 6.3
Inside Diameter (mm)	35.08	53.1	77.92	103.1	128.5	154.08	206.5
Allowable Tolerance on ID (mm)	34.5-35.7	52-53.7	77-78.7	102-103.7	127-128.7	153-154.7	206-207.7
Suggested Steel Specification	API 5L Grade B	ST.52 DIN 1629	API 5L Grade B	API 5L Grade B	ST.52 DIN 1629	API 5L Grade B	API 5L Grade B
Minimum Frame Length (mm)	120	120	160	160	160	160	160

**STEP 1:** Select the outside diameter of the service pipe from the table.

**STEP 2:** Read along the row to select the correct plug size and type.

**STEP 3:** Read down the column to select the correct penetration sleeve.

The internal diameter of the chosen sleeve is critical to ensure a water tight seal. The ID must be within the tolerance indicated in the table.

Penetration sleeves are available direct from CSD, sized to suit and with a bevel applied to the inside edge to aid insertion of the SLIPSIL plugs.

Mild steel is supplied as standard and can be coated to your specification if required. Aluminium, Stainless Steel and GRP sleeves are also available.

The above is not a complete listing of plugs available, but does cover the majority of requirements. If it does not cover yours, please request a complete listing of available sizes.

**Note:** New plug series are added to the range on a regular basis. Please contact our sales department when there is a need for a new series not listed above.

# Plastic pipes.

## SLIPSIL Sealing Plugs and RISE Ultra.

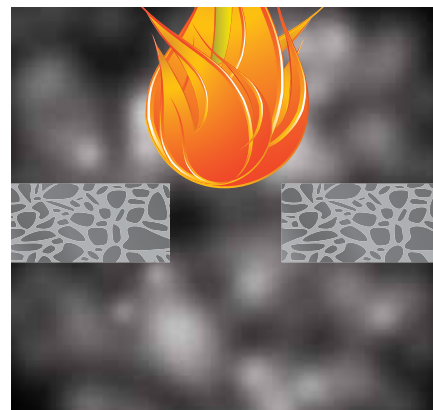
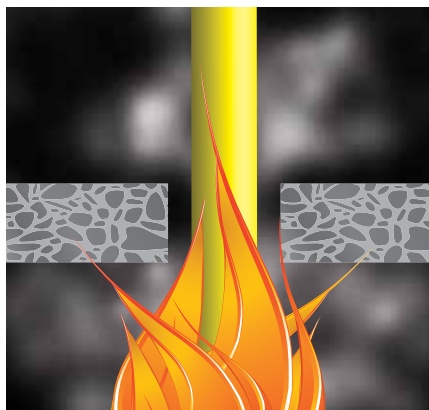
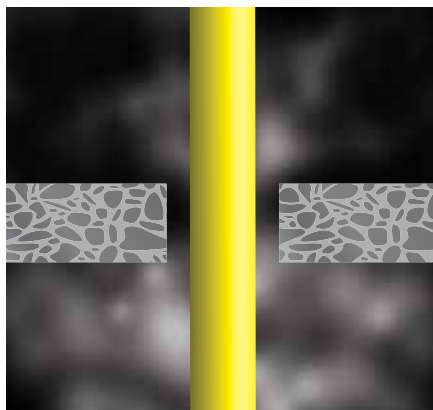

Plastic pipes which pass through fire-rated walls and floors as part of, for example, sanitation systems, create serious problems in case of fire.

Most plastic pipes start to soften at a temperature of about 75°C and ignite at a temperature of about 140°C. This means that, should a fire occur, a hole will be formed by the softened or combusted plastic pipe, allowing fumes and flames to spread freely.

To address this problem, the SLIPSIL Plug System and RISE Ultra has been developed.

To avoid smoke and fire spread RISE rubber is used; type FRR-EHF (fire resistant rubber – expanding, halogen free). This rubber is placed between SLIPSIL Sealing Plugs which are made of NOFIRNO rubber.

When exposed to temperatures above 200°C or flames, RISE rubber will expand vigorously, to more than ten times its original volume and with such a force that even a thin wall aluminium pipe will be crushed. This means that in case of a fire, no opening will be left in the conduit for the passage of smoke and flames.

The cavity between both SLIPSIL plugs needs to be partly filled with RISE rubber strips or sleeves. Other than with PE/ALU pipes, the time to close off the opening left by the burned or softened plastic pipe is very short. If the reaction is too late,

a chimney effect will occur, causing the pipe at the unexposed side to melt.

RISE rubber will expand as soon as the conduit sleeve is subjected to heat, and as a result it will seal off the opening created by the softened or combusted plastic pipe in a very short time.

The expanded RISE rubber possesses good thermal insulation properties, ensuring that the softened pipe will re-harden after compression.

NOFIRNO rubber will form a char at the front exposed side of the SLIPSIL plug and will slightly expand.

In this way, the RISE rubber is fully enclosed and can only expand in the direction of the softened plastic pipe.

The SLIPSIL plug at the unexposed side will keep the penetration smoke tight during the fire. The SLIPSIL plug system is a push-in system and requires no complicated installation work.

It is fireproof, gastight and watertight.

This is accredited to EN13501-2:2003 in accordance BSEN1366-3.

## RISE Ultra

RISE Ultra plastic pipe penetrations are a newly developed version of Beele Engineering and CSD's CRUSHER technology used in all our RISE products. It uses a combination of adhesion followed by rapid and extreme expansion, resulting in a solid, stable filling of the conduit opening, closing off any gaps left by the melting plastic pipe.

The RISE Ultra's effectiveness comes from its reaction at two different temperature levels.

Firstly, the rubber becomes very adhesive, bonding itself to the ducted pipe and then following the initial stage of expansion, bonding itself to the inside wall of the conduit opening. The next stage of the reaction as the temperatures increase further is a huge expansion of material which crushes the softening plastic pipe quickly and prevents any smoke or fire breakthrough. The resulting rubber mass is then extremely stable and will withstand extended exposure to fire.

# Installation layout.

## Plastic pipe penetration walls and floors

**L1:** 250mm

**L2:** 80mm wide strips of RISE strip to be wrapped around the ducted pipe to a minimum thickness of  $1/4 \times D$ , rounded up to the nearest  $\pm 5$ mm. For pipe sizes up to 42mm, a pre-formed sleeve of the required thickness is available. Available sizes are:

Pipe OD	RISE Sleeve
15	35/16
16	35/16
20	39/20
22	46/22
25	46/26
30	46/30
32	52/32
40	64/40
50	2.5mm wrap - minimum 4 layers
63	2.5mm wrap - minimum 6 layers
75	2.5mm wrap - minimum 6 layers
90	2.5mm wrap - minimum 8 layers
110	2.5mm wrap - minimum 10 layers
160	2.5mm wrap - minimum 16 layers

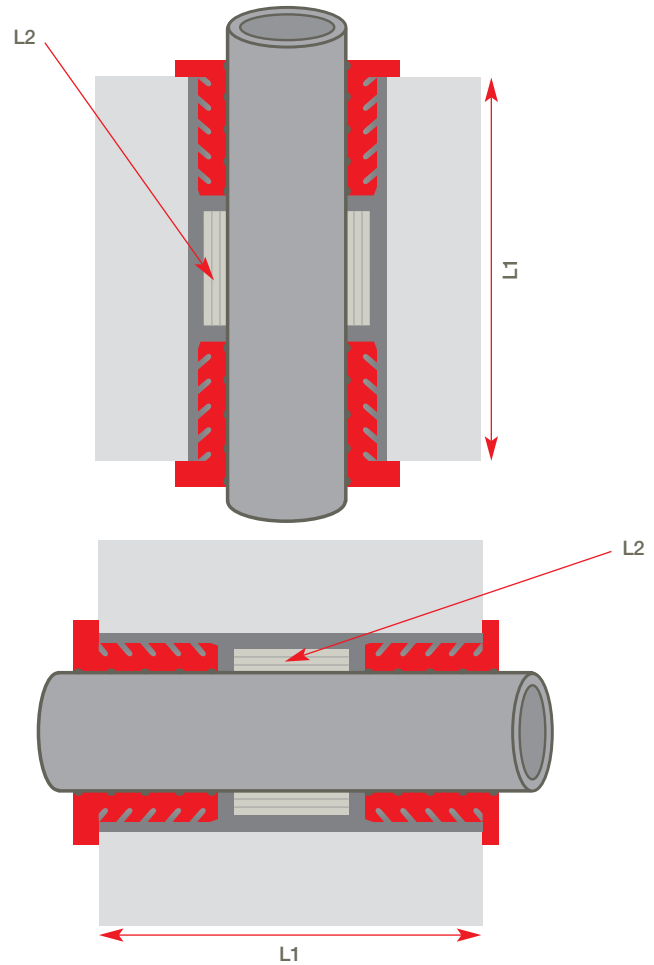

ID of conduit sleeve to be within the tolerances detailed on page 35.

SLIPSIL sealing plugs to be inserted both sides of the conduit (either core drilled concrete or ducting are suitable).

STEP 1 Plastic Service Pipe Sizes	
	MM
	15
	16
1/2"	20
	22
3/4"	25
	30
1"	32
1 1/4"	40
1 1/2"	50
2"	63
2 1/2"	75
3"	90
4"	110
6"	160

STEP 2 Slipsil Plug to suit service pipe						
SERIES 35	SERIES 53	SERIES 78	SERIES 103	SERIES 128	SERIES 154	SERIES 207
(Suits 15-16mm)	(Suits 15-32mm)	(Suits 22-50mm)	(Suits 40-63mm)	(Suits 62-75mm)	(Suits 90mm)	(Suits 110-160mm)
35/15-16	53/14-16					
35/16-18	53/16-18					
	53/20-22					
	53/22-24	78/22-24				
	53/24-26	78/24-26				
	53/30-31	78/30-32				
	53/32-33	78/32-34				
		78/40-42	103/40-42			
		78/50	103/50-52			
			103/62-64	128/62-64		
				128/74-76		
					154/90-92	
						207/110
						207/160

STEP 3							
NB	1 1/4"	2"	3"	4"	5"	6"	8"
OD & Wall Thickness (mm)	42.2 x 3.56	60.3 x 3.6	88.9 x 5.49	114.3 x 5.6	139.7 x 5.6	168.3 x 7.11	219.1 x 6.3
Inside Diameter (mm)	35.08	53.1	77.92	103.1	128.5	154.08	206.5
Allowable Tolerance on ID (mm)	34.5-35.7	52-53.7	77-78.7	102-103.7	127-128.7	153-154.7	206-207.7
Suggested Steel Specification	API 5L Grade B	ST.52 DIN 1629	API 5L Grade B	API 5L Grade B	ST.52 DIN 1629	API 5L Grade B	API 5L Grade B
Minimum Frame Length (mm)	200	200	200	200	200	250	250
CSD Part Number	FRAME35X200	FRAME53X200	FRAME78X200	FRAME103X200	FRAME128X200	FRAME154X160	FRAME207X160



**THORNE & DERRICK INTERNATIONAL**

**Thorne & Derrick**  
+44 (0) 191 410 4292  
www.powerandcables.com