

Surge arrester POLIM-H..SD



Product description

Surge arrester with metal-oxide resistors without spark gaps (MO surge arrester), direct molded silicone housing, grey color, designed and tested according to EN 50526-1 and IEC 62848-1.

The metal-oxide resistors are from own production line.

Overvoltage protection of

- Traction systems – fixed installations
- Rolling stock
- Equipment in direct current installations

Application

- Systems with direct current (DC)
- Outdoor and indoor installations

Additional certification

- Shock and vibration tested according to IEC 61373
- Fire and smoke behaviour tested and classified according to EN 45545-2

Technical data

Classification according to EN 50526-1 and IEC 62848-1

Nominal discharge current I_n (8/20 μ s)	10 kA _{peak}
Class	DC-B
High current impulse I_{hc} (4/10 μ s)	100 kA _{peak}
Switching current impulse I_{sw} (30/60 μ s)	1000 A _{peak}
Charge transfer capability Q_t	2.5 As
Energy withstand capability W	9.5 kJ/kV _{UC}
Short circuit rating I_s	40 kA DC for 0.2 s

The thermal stability of the MO surge arrester is proved in the operating duty test according to class DC-B with two impulses of the charge transfer capability Q_t (total 5 As).

Classification according IEC 60099-4

Arrester class	SH, Station High
Line discharge class (LD)	4
Nominal discharge current I_n (8/20 μ s)	20 kA _{peak}
Repetitive charge transfer rating Q_{rs}	2.4 As (C)
Long duration current impulse	1350 A for 2000 μ s

Mechanical loads

Torque	50 Nm
Tensile strength axial	1000 N
Short term load SSL perpendicular to axis	225 Nm
Long term load SLL perpendicular to axis	180 Nm

Service conditions

Ambient air temperature T_{amb}	-60 to +40 °C (for temperatures up to 80 °C consider instructions of application guidelines)
Altitude	up to 1800 m (for higher altitudes contact manufacturer)



Thorne & Derrick
+44 (0) 191 410 4292
www.powerandcables.com

Electrical data

$U_c (= U_r)$ *	Residual voltage U_{res} at specified impulse current									
	Steep current impulse wave 1/... μ s		Lightning current impulse wave 8/20 μ s					Switching current impulse wave 30/60 μ s		
	5 kA	10 kA	1 kA	2 kA	5 kA	$I_n=10$ kA	20 kA	250 A	500 A	1000 A
kV DC	kV _{peak}	kV _{peak}	kV _{peak}	kV _{peak}	kV _{peak}	kV _{peak}	kV _{peak}	kV _{peak}	kV _{peak}	kV _{peak}
0.14	0.35	0.38	0.30	0.32	0.33	0.34	0.38	0.28	0.29	0.30
0.29	0.72	0.77	0.61	0.64	0.68	0.70	0.77	0.58	0.60	0.61
0.36	0.88	0.94	0.75	0.79	0.83	0.86	0.94	0.71	0.73	0.75
0.49	1.20	1.28	1.02	1.07	1.13	1.17	1.28	0.96	0.99	1.02
0.56	1.37	1.47	1.17	1.23	1.29	1.34	1.47	1.10	1.14	1.17
0.85	2.08	2.22	1.77	1.86	1.95	2.03	2.22	1.67	1.72	1.77
1.0	2.43	2.60	2.08	2.18	2.29	2.38	2.60	1.96	2.01	2.07
1.5	3.65	3.90	3.11	3.26	3.43	3.57	3.90	2.93	3.02	3.10
2.0	4.86	5.19	4.15	4.35	4.57	4.76	5.19	3.91	4.02	4.14
2.5	6.07	6.49	5.18	5.44	5.71	5.95	6.49	4.88	5.03	5.17
3.0	7.29	7.79	6.22	6.52	6.85	7.14	7.79	5.86	6.03	6.20
4.2	10.20	10.90	8.70	9.13	9.58	10.00	10.90	8.20	8.44	8.68

* The rated voltage U_r of the arrester coincides with the continuous operating voltage U_c .

Housing

U_c Continuous operating voltage	Creepage distance	Flashover distance	Height	Weight	Insulation withstand voltage of empty housing			
					1.2/50 μ s		1 min wet	
					required values acc. to EN	guaranteed	required values acc. to EN	guaranteed
kV DC	mm	mm	mm	kg	kV _{peak}	kV _{peak}	kV DC	kV DC
0.14	232	120	90	≤ 2.0	0.50	95	0.34	30
0.29	232	120	90	≤ 2.0	1.03	95	0.70	30
0.36	232	120	90	≤ 2.0	1.27	95	0.86	30
0.49	232	120	90	≤ 2.0	1.72	95	1.17	30
0.56	232	120	90	≤ 2.0	1.97	95	1.34	30
0.85	232	120	90	≤ 2.0	2.99	95	2.03	30
1.0	232	120	90	≤ 2.0	3.50	95	2.38	30
1.5	232	120	90	≤ 2.0	5.25	95	3.57	30
2.0	232	120	90	≤ 2.0	7.00	95	4.76	30
2.5	232	120	90	≤ 2.0	8.75	95	5.95	30
3.0	232	120	90	≤ 2.0	10.50	95	7.14	30
4.2	232	120	90	≤ 2.0	14.70	95	10.00	30

Dimensions (mm)

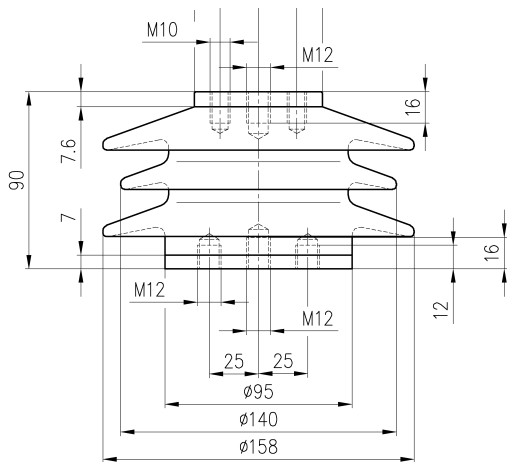

Dimensions according to outline drawing 1HC0050941
Outline drawings with accessories on request

Structure of type designation

POLIM-H 1.5 SD

Type of arrester _____
 U_c = Continuous operating voltage _____
 Housing _____
 Direct current _____

Structure of type designation with optional accessories (Example)

POLIM-H 1.5 SD / 1215 / 2216

Type of surge arrester _____
 Type of top accessory (optional) _____
 Type of bottom accessory (optional) _____

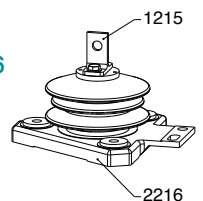

Common Top Accessories (optional)

Dimensions (mm)

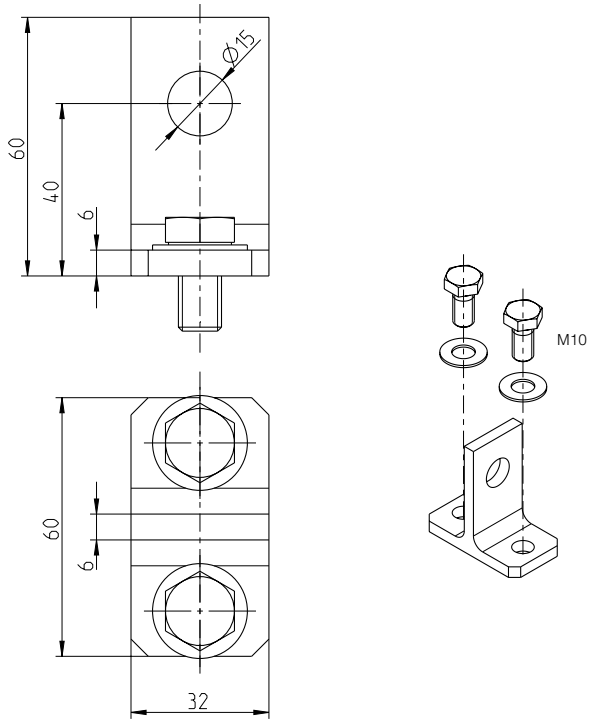

Type 1215 Flat terminal (aluminium alloy)

Common Bottom Accessories (optional)

Dimensions (mm)

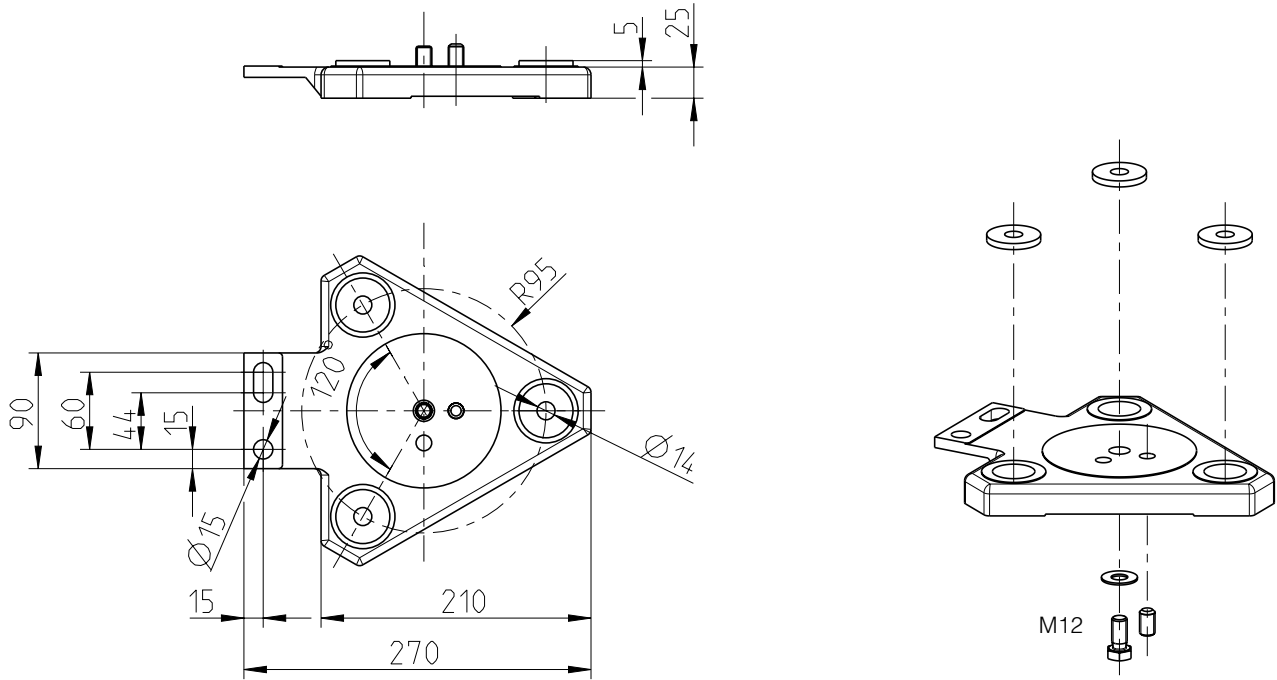

Type 2216 3-points reinforced base R = 95 – (aluminium alloy)

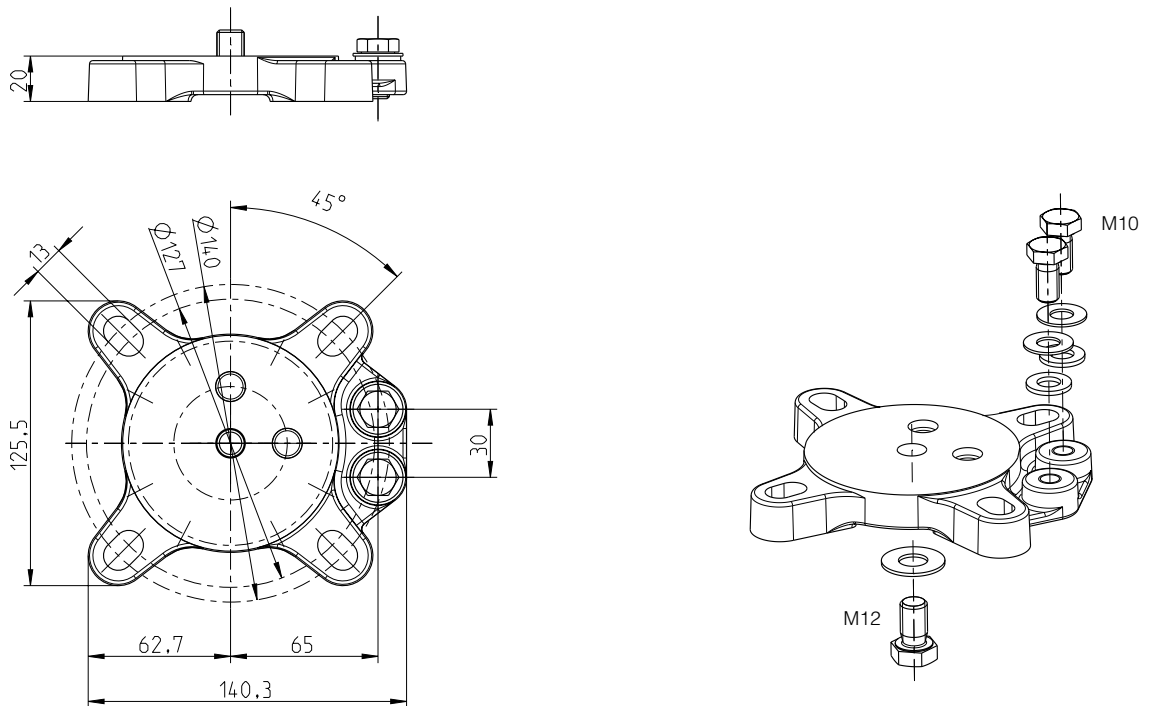

Type 2149 4-points reinforced base (aluminium alloy)

Common Bottom Accessories (optional)

Dimensions (mm)

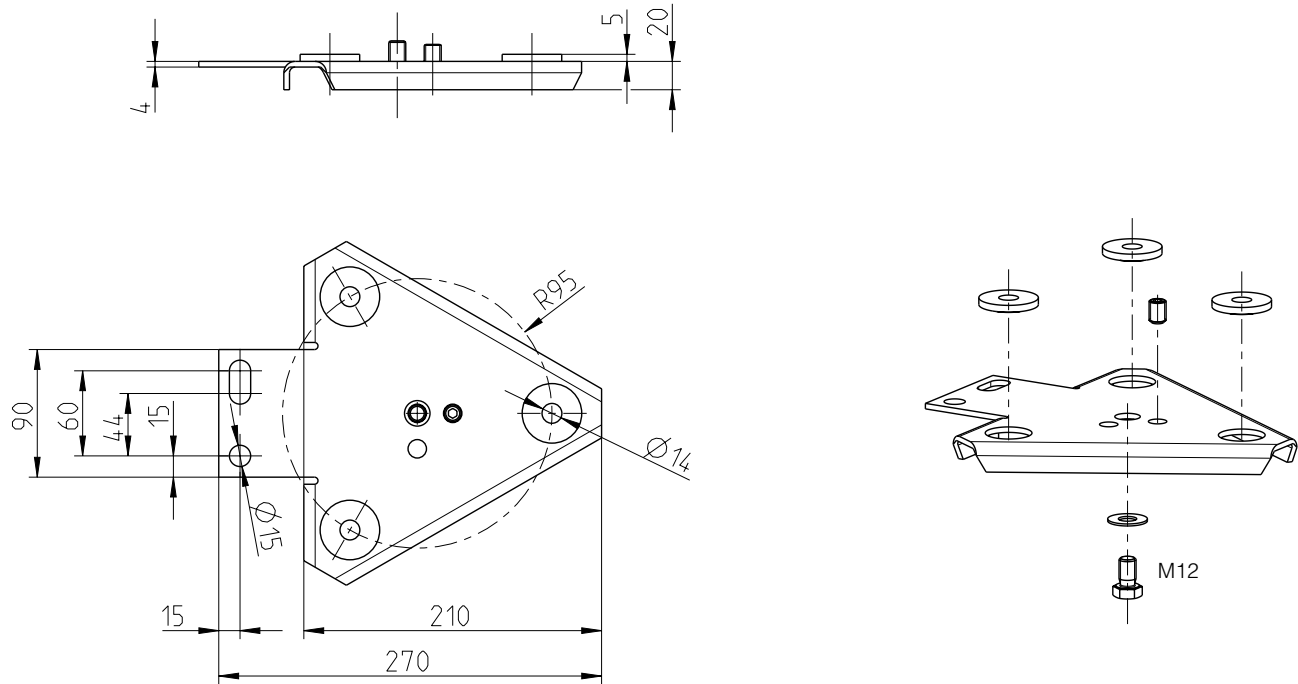

Type 2223 3-points base R = 95 (hot-dip galvanized steel)

For further information please contact:

**ABB Switzerland Ltd
High Voltage Products**

Surge Arresters

Jurastrasse 45

CH-5430 Wettingen/Switzerland

Tel. +41 58 585 29 11

Fax +41 58 585 55 70

E-mail: sales.sa@ch.abb.com

www.abb.com/arrestersonline

For detailed information regarding the dimensioning of our products see the following ABB documents:

- Application guidelines
Overvoltage protection
Metal oxide surge arresters in medium voltage systems
- Application guidelines
Overvoltage protection
Metal oxide surge arresters in railway facilities

For pdf or print version please send E-mail to:
sales.sa@ch.abb.com

Note

We reserve the right to make technical changes or modify the contents of this document without prior notice. With regard to purchase orders the agreed particulars shall prevail. ABB AG does not accept any responsibility whatsoever for potential errors or possible lack of information in this document. We reserve all rights in this document and in the subject matter and illustrations contained therein. Any reproduction, disclosure to third parties or utilization of its contents – in whole or in parts – is forbidden without prior written consent of ABB AG.

Copyright © 2016 ABB

All rights reserved

Our products are certified according ISO 9001, 14001, 18001 and IRIS

1HC0075860 EN AD



Thorne & Derrick
+44 (0) 191 410 4292
www.powerandcables.com

Power and productivity
for a better world™

