

Surge arrester POLIM-K



Overvoltage protection of

- Transformers
- Motors
- Cables
- Cable sheaths
- Medium voltage equipment

Application

- Alternating current (AC)
- Outdoor and indoor

Technical data

Surge arrester with metal oxide resistors without spark gaps (MO surge arrester), direct molded silicon housing, gray color, designed and tested according to IEC 60099-4.

Nominal discharge current I_n 8/20 μ s	10 kA (pk)
Line discharge class (LD)	2
High current impulse I_{hc} 4/10 μ s	100 kA (pk)
Long duration current impulse	500 A / 2000 μ s
Short circuit rating I_s 50 Hz	50 kA (rms) for 0.2 s
Classification according to IEEE (ANSI) C62.11	intermediate

The thermal stability of the MO surge arrester is proved in the operating duty test according to LD 2, which gives an energy input of 5.2 kJ/kV (U_c).

Power frequency voltage versus time characteristic (TOV) with prior energy input

$t = 1$ s	$U_{TOV} = 1.312 \times U_c$
$t = 3$ s	$U_{TOV} = 1.285 \times U_c$
$t = 10$ s	$U_{TOV} = 1.258 \times U_c$

Mechanical loads

Torque moment	50 Nm
Tensile strength axial	1000 N
Short term load SSL horizontal to axis	250 Nm
Long term load SLL horizontal to axis	250 Nm

General data

Ambient air temperature	-60 to +40 °C (for higher values contact manufacturer)
Altitude	up to 1800 m (for higher values contact manufacturer)
Frequency of system voltage	50/60 Hz
Weather ageing test	tested according to test series A (1000 h salt fog)



Thorne & Derrick
+44 (0) 191 410 4292
www.powerandcables.com

Electrical data

U_c Continuous operating voltage	U_r Rated voltage	Residual voltage U_{res} in kV (pV) at specified impulse current									
		wave 1/... μ s		wave 8/20 μ s					wave 30/60 μ s		
		5 kA	10 kA	1 kA	2.5 kA	5 kA	10 kA	20 kA	125 A	250 A	500 A
kV	kV	5 kA	10 kA	1 kA	2.5 kA	5 kA	10 kA	20 kA	125 A	250 A	500 A
rms	rms	pV	pV	pV	pV	pV	pV	pV	pV	pV	pV
4	5.0	13.0	14.7	10.9	11.7	12.4	13.4	14.9	9.7	10.0	10.3
5	6.3	16.2	18.3	13.6	14.5	15.4	16.7	18.6	12.1	12.5	12.9
6	7.5	19.4	21.9	16.3	17.4	18.5	20.0	22.2	14.5	14.9	15.4
7	8.8	22.7	25.7	19.1	20.3	21.6	23.4	26.0	17.0	17.5	18.0
8	10.0	25.9	29.3	21.7	23.2	24.7	26.7	29.7	19.4	19.9	20.6
9	11.3	29.1	32.9	24.4	26.0	27.7	30.0	33.3	21.7	22.4	23.1
10	12.5	32.3	36.5	27.1	28.9	30.8	33.3	37.0	24.1	24.9	25.6
11	13.8	35.6	40.2	29.9	31.8	33.9	36.7	40.8	26.6	27.4	28.2
12	15.0	38.8	43.8	32.5	34.7	36.9	40.0	44.4	29.0	29.8	30.8
13	16.3	42.0	47.4	35.2	37.6	40.0	43.3	48.1	31.4	32.3	33.3
14	17.5	45.3	51.1	38.0	40.5	43.1	46.7	51.9	33.8	34.8	35.9
15	18.8	48.5	54.8	40.7	43.4	46.1	50.0	55.5	36.2	37.3	38.5
16	20.0	51.6	58.4	43.3	46.2	49.2	53.3	59.2	38.6	39.8	41.0
17	21.3	54.9	62.1	46.1	49.2	52.3	56.7	63.0	41.0	42.3	43.6
18	22.5	58.1	65.7	48.8	52.0	55.4	60.0	66.6	43.4	44.7	46.1
19	23.8	61.3	69.3	51.5	54.9	58.4	63.3	70.3	45.8	47.2	48.7
20	25.0	64.5	72.9	54.1	57.7	61.5	66.6	74.0	48.2	49.7	51.2
21	26.3	67.8	76.6	56.9	60.7	64.6	70.0	77.7	50.7	52.2	53.8
22	27.5	71.0	80.2	59.6	63.5	67.6	73.3	81.4	53.0	54.7	56.3
23	28.8	74.2	83.9	62.3	66.4	70.7	76.6	85.1	55.4	57.1	58.9
24	30.0	77.5	87.6	65.0	69.3	73.8	80.0	88.8	57.9	59.6	61.5
25	31.3	80.7	91.2	67.7	72.2	76.9	83.3	92.5	60.3	62.1	64.0
26	32.5	83.9	94.8	70.4	75.1	79.9	86.6	96.2	62.7	64.6	66.6
27	33.8	87.2	98.5	73.2	78.0	83.0	90.0	99.9	65.1	67.1	69.2
28	35.0	90.4	102.1	75.8	80.9	86.1	93.3	103.6	67.5	69.6	71.7
29	36.3	93.6	105.7	78.5	83.7	89.1	96.6	107.3	69.9	72.0	74.2
30	37.5	96.8	109.4	81.2	86.6	92.2	99.9	110.9	72.3	74.5	76.8
31	38.8	100.1	113.1	84.0	89.5	95.3	103.3	114.7	74.7	77.0	79.4
32	40.0	103.2	116.7	86.6	92.4	98.3	106.6	118.4	77.1	79.5	81.9
33	41.3	106.4	120.3	89.3	95.3	101.4	109.9	122.0	79.5	81.9	84.5
34	42.5	109.7	124.0	92.1	98.2	104.5	113.3	125.8	82.0	84.5	87.1
35	43.8	112.9	127.6	94.8	101.1	107.6	116.6	129.5	84.4	86.9	89.6
36	45.0	116.1	131.2	97.4	103.9	110.6	119.9	133.1	86.7	89.4	92.1
37	46.3	119.4	135.0	100.2	106.9	113.7	123.3	136.9	89.2	91.9	94.8
38	47.5	122.6	138.6	102.9	109.7	116.8	126.6	140.6	91.6	94.4	97.3
39	48.8	125.8	142.2	105.6	112.6	119.8	129.9	144.2	94.0	96.8	99.8
40	50.0	129.0	145.8	108.2	115.4	122.9	133.2	147.9	96.4	99.3	102.4
41	51.3	132.3	149.5	111.0	118.4	126.0	136.6	151.7	98.8	101.8	105.0
42	52.5	135.5	153.1	113.7	121.2	129.0	139.9	155.3	101.2	104.3	107.5
43	53.8	138.7	156.7	116.4	124.1	132.1	143.2	159.0	103.6	106.7	110.0
44	55.0	142.0	160.4	119.1	127.0	135.2	146.6	162.8	106.0	109.3	112.6

Housings

U_c Continuous operating voltage kV rms	Housing sizes									Recommended clearances	
	10	20	30	40	50	60	70	80	90	E_{min}	F_{min}
	Creepage distance									mm	mm
	mm	mm	mm	mm	mm	mm	mm	mm	mm	mm	mm
4	04-10	04-20								67	132
5	05-10	05-20								77	132
6	06-10	06-20								88	132
7	07-10	07-20	07-30							98	132
8		08-20	08-30							109	132
9		09-20	09-30	09-40						119	142
10		10-20	10-30	10-40	10-50					130	152
11		11-20	11-30	11-40	11-50					140	163
12		12-20	12-30	12-40	12-50	12-60				151	173
13			13-30	13-40	13-50	13-60				161	183
14			14-30	14-40	14-50	14-60	14-70			172	194
15			15-30	15-40	15-50	15-60	15-70			182	204
16			16-30	16-40	16-50	16-60	16-70	16-80		193	214
17				17-40	17-50	17-60	17-70	17-80		203	225
18				18-40	18-50	18-60	18-70	18-80		214	235
19				19-40	19-50	19-60	19-70	19-80		224	246
20				20-40	20-50	20-60	20-70	20-80	20-90	235	256
21					21-50	21-60	21-70	21-80	21-90	245	266
22					22-50	22-60	22-70	22-80	22-90	256	277
23					23-50	23-60	23-70	23-80	23-90	266	287
24					24-50	24-60	24-70	24-80	24-90	277	297
25						25-60	25-70	25-80	25-90	287	308
26						26-60	26-70	26-80	26-90	298	318
27						27-60	27-70	27-80	27-90	308	329
28						28-60	28-70	28-80	28-90	319	339
29							29-70	29-80	29-90	329	349
30							30-70	30-80	30-90	339	360
31							31-70	31-80	31-90	350	370
32							32-70	32-80	32-90	361	380
33								33-80	33-90	371	391
34								34-80	34-90	382	401
35								35-80	35-90	392	412
36								36-80	36-90	403	422
37									37-90	413	432
38									38-90	424	443
39									39-90	434	453
40									40-90	445	463
41									41-90	455	474
42									42-90	466	484
43									43-90	476	494
44									44-90	487	505

Housings

Housing sizes	Creepage distance	Flashover distance	Height H mm	Weight kg	Insulation withstand of housing	
	mm	mm			1.2/50 μ s kV (pv)	50 Hz, 60 s, wet kV (rms)
10	264	159	159	< 1.6	90	40
20	384	199	199	< 2.0	110	50
30	504	239	239	< 2.6	135	60
40	625	279	279	< 3.0	160	70
50	745	319	319	< 3.4	180	80
60	865	359	359	< 3.8	200	90
70	985	399	399	< 4.2	225	100
80	1135	432	429	< 4.6	245	110
90	1460	552	549	< 5.6	310	150

Comparison table housing sizes

Old designation	New designation
	POLIM-K.-10
POLIM-K..-02	POLIM-K.-20
	POLIM-K.-30
	POLIM-K.-40
POLIM-K..-04	POLIM-K.-50
	POLIM-K.-60
	POLIM-K.-70
POLIM-K..-06	POLIM-K.-80
POLIM-K..-08	POLIM-K.-90

Structure of type designation

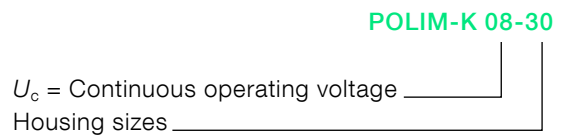

Note: Equivalent housing sizes may have slight differences in dimensions, creepage distance and clearances. The actual data sheet has to be considered all time.

Figure 1: Dimensions (in mm)

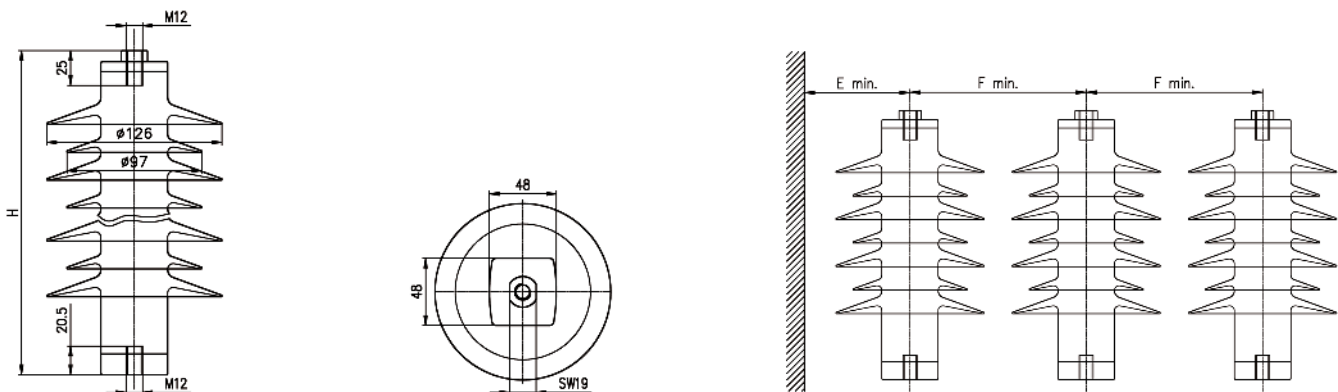

For further information please contact:

**ABB Switzerland Ltd
High Voltage Products**

Surge Arresters

Jurastrasse 45

CH-5430 Wettingen/Switzerland

Tel. +41 58 585 29 11

Fax +41 58 585 55 70

E-mail: sales.sa@ch.abb.com

www.abb.com/arrestersonline

For detailed information for dimensioning of our products
see following ABB documents:

- Application guidelines Overvoltage protection Metal oxide surge arresters in medium voltage systems
- Application guidelines Overvoltage protection Metal oxide surge arresters in railway facilities

For pdf or print version please send E-mail to:
sales.sa@ch.abb.com

Note

We reserve the right to make technical changes or modify the contents of this document without prior notice. With regard to purchase orders the agreed particulars shall prevail. ABB AG does not accept any responsibility whatsoever for potential errors or possible lack of information in this document. We reserve all rights in this document and in the subject matter and illustrations contained therein. Any reproduction, disclosure to third parties or utilization of its contents – in whole or in parts – is forbidden without prior written consent of ABB AG.

Copyright © 2013 ABB
All rights reserved

Our products are certified according ISO 9001, 14001, 18001 and IRIS

1HC0075855 E01 AC



THORNE &
DERRICK
INTERNATIONAL

Thorne & Derrick
+44 (0) 191 410 4292
www.powerandcables.com

Power and productivity
for a better world™

