

SIEMENS



Catalog
HA 25.71 ·
Edition 2016

Air-Insulated Medium-Voltage Switchgear NXAIR, up to 24 kV

Medium-Voltage Switchgear

siemens.com/nxair

Application

Typical applications

R-HA25-362.tif



NXAIR circuit-breaker switchgear is used in transformer and switching substations, mainly at the primary distribution level, e.g.:

Application

Public power supply

- Power supply companies
- Energy producers
- System operators.

R-HA25-366.tif



R-HA35-0510-016.tif
Photo: Harald M. Valderhaug

Application

Industry and offshore

- Automobile industry
- Traction power supply systems
- Mining industry
- Lignite open-cast mines
- Chemical industry
- Diesel power plants
- Electrochemical plants
- Emergency power supply installations
- Textile, paper and food industries
- Iron and steel works
- Power stations
- Petroleum industry
- Offshore installations
- Petrochemical plants
- Pipeline installations
- Data centers
- Shipbuilding industry
- Steel industry
- Rolling mills
- Cement industry.

R-HA25-363.tif



Air-Insulated Medium-Voltage Switchgear NXAIR, up to 24 kV

Medium-Voltage Switchgear

Catalog HA 25.71 · 2016

Invalid: Catalog HA 25.71 · 2014

siemens.com/nxair



The products and systems described in this catalog are manufactured and sold according to a certified management system (acc. to ISO 9001, ISO 14001 and BS OHSAS 18001).

Application	Page
Typical applications	2
Customer benefit	
Ensures peace of mind	4
Saves lives	5
Increases productivity	6
Saves money	7
Preserves the environment	8
Design	
Classification	9
Basic panel design, operation	10 and 11
Compartments	12
Components	
Vacuum circuit-breaker	13
Vacuum contactor	14
Current transformers	15
Voltage transformers	16
Low-voltage compartment	17
Technical data 17.5 kV	
Electrical data	18
Product range, switchgear panels	19 and 20
Dimensions	21
Room planning	22
Transport and packing	23
Technical data 24 kV	
Electrical data	24
Product range, switchgear panels	25 and 26
Dimensions	27
Room planning	28
Transport and packing	29
Standards	
Standards, specifications, guidelines	30 and 31

Customer benefit

Ensures peace of mind



For power supply companies and industrial plants, the platform concept of the NXAIR family introduced at all production locations has very concrete advantages:

Smooth operation, exemplary availability and optimal safety.

Features

- No handling of insulating gas and low and high pressure monitoring required
- As insulating medium, air is always available
- Factory-assembled, type-tested switchgear according to IEC 62271-200 or VDE 0671-200
- Platform concept introduced worldwide, centrally controlled development, local manufacture
- Use of standardized block-type current transformers
- Use of standard components available worldwide, locally manufactured components, and consideration of regional standards
- More than 450,000 air-insulated switchgear panels of Siemens in operation worldwide
- Use of maintenance-free vacuum circuit-breakers or contactors
- Type testing of the vacuum circuit-breaker and the make-proof earthing switch in the panel
- Pressure-resistant partitions
- Flexibility regarding the low-voltage equipment (removable compartment, plug-in wires)
- Quality assurance in accordance with DIN EN ISO 9001.



All switchgear types of the NXAIR family are approved with internal arc classification IAC A FLR, loss of service continuity category LSC 2B and partition class PM.

This makes them suitable for universal installation, meeting the highest requirements regarding personal safety.

Features

- All operations with closed high-voltage door
- Metallic enclosure, earthed shutters and partitions
- Internal arc classified switchgear according to IAC A FLR; front, lateral and rear accessibility; for all short-circuit currents and an arc duration of 1 s, optionally 0.1 s
- Loss of service continuity category LSC 2B (separate partitions for busbar, connection and switching-device compartments)
- Partition class PM (metal-clad in pressure-resistant design)
- Unambiguous position indicators and control elements on the high-voltage door
- Use of vacuum circuit-breakers or contactors
- Standard degree of protection IP3XD; different degrees of protection possible as an option
- Positively driven shutters (separately lockable)
- Logical mechanical interlocking system.

Customer benefit

Increases productivity



Properties such as modular design, type tests of the circuit-breaker in the switchgear, confinement of an internal arc to the respective compartment, and thus maximum operational reliability, contribute to optimum operation and a remarkable increase of productivity.

Features

- Loss of service continuity category LSC 2B (separate partitions for busbar, connection and switching-device compartments)
- Partition class PM
- Maximum degree of protection IP51 possible
- Positively driven shutters
- Use of standardized block-type current transformers
- Cable testing without isolating the busbar
- Functions such as establishment of the isolating distance, as well as feeder and busbar earthing, can be completely controlled from remote
- Confinement of an internal arc to the respective compartment up to 31.5 kA
- Use of maintenance-free vacuum circuit-breakers or contactors
- Control cables in metallic wiring ducts
- Easy access to all panel components.



The compact design of the NXAIR family pays twice for owners due to the use of the new SION circuit-breaker series.

On the one hand, building costs can be reduced in this way, and on the other hand, the maintenance-free circuit-breakers and the modular design enable continuous operation without expensive shutdown times.

Features

- Use of maintenance-free vacuum circuit-breakers or contactors
- Maintenance-free switchgear within up to 10 years
- Interruption of operation reduced to a minimum by logical mechanical interlocking system
- Minimized space requirements (reduced building investments) due to compact design and flexible cable connection options and /or flexible pressure relief duct systems.

Customer benefit

Preserves the environment



Air used as insulating medium, local production locations with short transportation ways and times, as well as a service life of more than 30 years, optimize the total energy balance.

Features

- As insulating medium, air is absolutely neutral to the environment
- Local production presence in all regions, minimized energy consumption (CO₂) regarding transport
- Service life of more than 30 years optimizes the energy balance additionally
- The materials used are fully recyclable without special knowledge
- Easy disposal.

Circuit-breaker switchgear NXAIR is factory-assembled, type-tested, metal-enclosed and metal-clad switchgear for indoor installation according to IEC 62271-200/ VDE 0671-200 and corresponds to the following classifications.



R-HA25-366.tif

Loss of service continuity category and partition class	
Loss of service continuity category	LSC 2B
Partition class	PM
Accessibility to compartments	
Busbar compartment	Tool-based
Switching-device compartment	Interlock-controlled
Connection compartment	Interlock-controlled or tool-based
Internal arc classifications	
The following internal arc classifications are fulfilled: IAC A FLR, I_{sc} , t	
IAC	= Internal arc classification
A	= 300 mm distance of indicators for test (installation in closed electrical service location)
F	= Front arrangement of indicators for test
L	= Lateral arrangement of indicators for test
R	= Rear arrangement of indicators for test
I_{sc}	= Test current for NXAIR ≤ 17.5 kV up to 50 kA = Test current for NXAIR 24 kV up to 25 kA
t	= Arc duration 1 s, optionally 0.1 s
In this way, NXAIR switchgear is suitable for unrestricted application (wall- or free-standing arrangement) in electrical service locations up to the maximum short-circuit ratings.	

Type approval

NXAIR switchgear has been type-approved by the following classification societies:

- Lloyds Register (LR)
- Det Norske Veritas (DNV)

The switchgear is therefore also approved for application on ships and platforms.



National approval GOST

By certification in the system GOST R in Russia, NXAIR switchgear is approved for application at the voltage levels 6 kV, 10 kV and 20 kV. Compliance with the requirements of the GOST standard has been confirmed in the Declarations No. POCC DE.MM04.Д02090 and No. POCC DE.MM04.Д01640. The approval is valid in the countries Russia, Belarus, Kazakhstan and Ukraine.

The application of NXAIR in all transmission and distribution systems in Russia is additionally authorized by the FSK/MRSK Approval No. 36-12 of May 17, 2012.



Design

Basic panel design, operation

Operation at the panel

Features

- Integrated mimic diagram
- Display of the respective switch positions for circuit-breaker CLOSED/OPEN, disconnected position, earthing switch CLOSED/OPEN, on the integrated mimic diagram
- Unambiguous assignment of actuating openings and control elements to the corresponding position indicators
- All switching operations always with high-voltage door closed
- Ergonomically favorable height for all control and indicator elements
- Option: Verification of safe isolation from supply for feeder or busbar by means of the capacitive voltage detecting system with panel front closed.

Interlocks

- Interlocking conditions specified according to IEC 62271-200/ VDE 0671-200 are fulfilled
- Feeder earthing switch can only be operated with switching device in disconnected position
- Switching device can only be racked on the movable part with the associated switching device OPEN position and with earthing switch OPEN
- Switching device can only be operated in interlocked disconnected or service position.

Beyond the specifications of the standards

- Coding prevents insertion of switching devices with a lower rated normal current into panels with a higher rated normal current
- Interlocking between the high-voltage door and the position of the withdrawable part
- Option: Electromagnetic interlocks, mechanical key interlocking systems, padlocks.

Basic panel design (example)

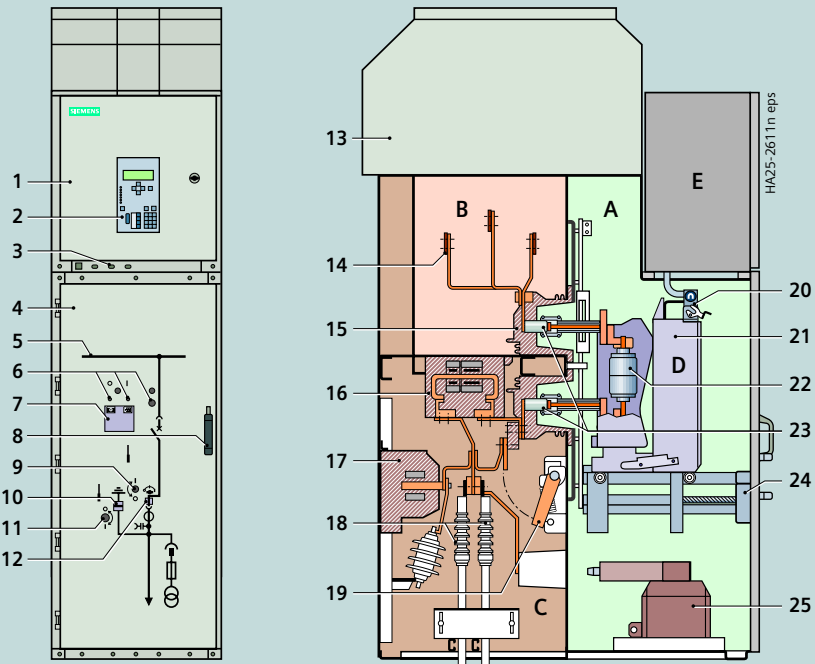

- | | |
|---|--|
| 1 Door to low-voltage compartment | 11 Actuating opening for feeder earthing switch, manual or optionally motor operation |
| 2 Protection device | 12 Mechanical position indicator for withdrawable part |
| 3 <u>Option:</u> Capacitive voltage detecting system for feeder and busbar | 13 Pressure relief duct, if required with top-mounted arc absorber |
| 4 High-voltage door | 14 Busbars |
| 5 Mimic diagram | 15 Bushing-type insulator |
| 6 "CLOSE-OPEN" actuating openings for the circuit-breaker, opening for spring charging | 16 Block-type current transformer |
| 7 Inspection window to recognize the "CLOSED-OPEN" indicator of the circuit-breaker, "closing spring charged" indicator, operations counter | 17 Voltage transformer |
| 8 Handle for opening the high-voltage door | 18 Cable connection |
| 9 Actuating opening for racking the switching device | 19 Make-proof earthing switch |
| 10 Mechanical position indicator for feeder earthing switch | 20 Low-voltage connection, plug-in type |
| | 21 Operating and interlocking unit for circuit-breaker |
| | 22 Vacuum interrupters |
| | 23 Contact system |
| | 24 Withdrawable part for racking the switching device and for earthing, manual or optionally motor operation |
| | 25 <u>Option:</u> Withdrawable voltage transformers |
-
- | |
|--------------------------------|
| A Switching-device compartment |
| B Busbar compartment |
| C Connection compartment |
| D Withdrawable circuit-breaker |
| E Low-voltage compartment |

Basic panel design (example) – Duplex (back-to-back)

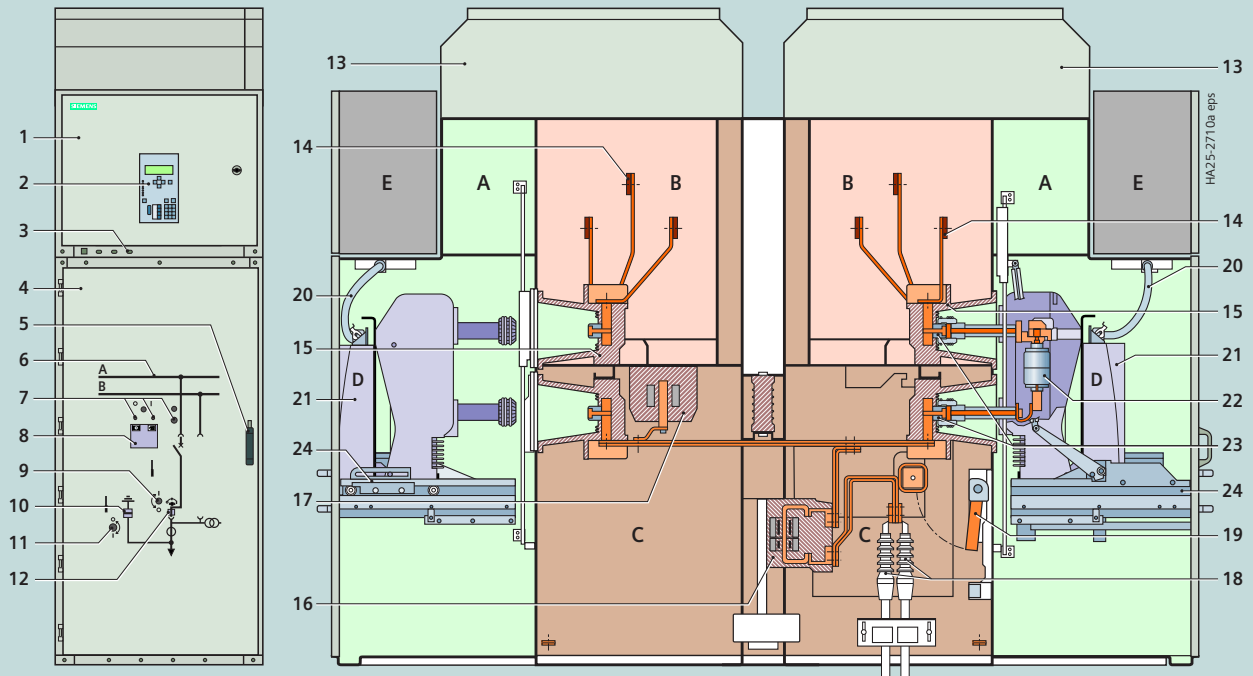

- | | |
|---|---|
| <ul style="list-style-type: none"> 1 Door to low-voltage compartment 2 Protection device 3 Option: Capacitive voltage detecting system for feeder and busbar 4 High-voltage door 5 Handle for high-voltage door 6 Mimic diagram 7 "CLOSE-OPEN" actuating openings for the circuit-breaker, opening for spring charging 8 Inspection window to recognize the "CLOSED-OPEN" indicator of the circuit-breaker, "closing spring charged" indicator, operations counter 9 Actuating opening for racking the switching device 10 Mechanical position indicator for feeder earthing switch | <ul style="list-style-type: none"> 11 Actuating opening for feeder earthing switch, manual or optionally motor operation 12 Mechanical position indicator for withdrawable part 13 Pressure relief duct, if required with top-mounted arc absorber 14 Busbars 15 Bushing-type insulator 16 Block-type current transformer 17 Voltage transformer 18 Cable connection 19 Make-proof earthing switch 20 Low-voltage connection, plug-in type 21 Operating and interlocking unit for circuit-breaker 22 Vacuum interrupters 23 Contact system 24 Withdrawable part for racking the switching device and for earthing, manual or optionally motor operation |
|---|---|

- A Switching-device compartment
- B Busbar compartment
- C Connection compartment
- D Withdrawable circuit-breaker
- E Low-voltage compartment

Design

Compartments

Switching-device compartment

- Enclosure made of sendzimir-galvanized sheet steel
- Pressure relief upwards
- Panel front powder-coated with epoxy resin
- Standard color RAL 7035
- Separate shutter mechanism for opening and closing the
 - Busbar compartment
 - Connection compartment
- High-voltage door pressure-resistant in the event of internal arcs in the panel
- Pressure-resistant partitions to connection and busbar compartments
- Lateral metallic wiring duct for laying the control cables
- Low-voltage plug connector for connection of control cables between primary part and secondary part
- Switching-device compartment for the different panel versions with withdrawable devices:
 - Vacuum circuit-breaker ¹⁾
 - Vacuum contactor
 - Disconnecter link
 - Metering unit
- Endurance classes for:
 - Circuit-breaker: E2, M2, C2
 - Isolating distance (withdrawable part): M0 manually or partly motor-operated for withdrawable circuit-breaker and disconnecter link
 - Vacuum contactor 250,000, 500,000 or 1,000,000 × I_N

Busbar compartment

- Enclosure made of sendzimir-galvanized sheet steel
- Pressure relief upwards
- Option: Transverse partition from panel to panel for NXAIR
Standard: Transverse partition from panel to panel for NXAIR for 40 kA and 50 kA
- Busbars made of flat copper, bolted from panel to panel
 - Option: Insulated
- Pressure-resistant partitions to connection and switching-device compartment, pressure-resistant rear wall
- Shutters can be opened and locked separately
- Bushing-type insulators for supporting the busbars and for accommodating the upper fixed contacts for the switching device
- Option: Coupling electrode for capacitive voltage detecting system.

Additional compartments (option) for busbar components, see also product range

- Top-mounted compartment over the busbar compartment, within the pressure relief duct
- Separate pressure relief of the additional compartment via pressure relief flaps
- Options: Possibility of installing the following components (but not for panels with natural and forced ventilation, see also product range)
 - Voltage transformers
 - Make-proof earthing switch (endurance class: M0, E1), manual or optionally motor operation
 - Bar or cable connection.

Connection compartment

- Enclosure made of sendzimir-galvanized sheet steel
- Pressure relief upwards through rear pressure relief duct
- Pressure-resistant partitions to switching-device and busbar compartments
- Shutters can be opened and locked separately
- Earthing busbar
- Option: Installation of bushing-type insulators or block-type current transformers
- Option: Coupling electrode for capacitive voltage detecting system
- Pressure-resistant floor cover
- Connection from front/bottom, or from rear/bottom, or from rear/top
- Suitable for connection of:
 - Single-core XLPE cables up to 6 x 500 mm² depending on the rated normal current and other built-in components
 - Three-core XLPE cables 3 x 240 mm² per panel depending on the rated normal current and other built-in components
 - Flat copper bars with bushings in a base plate or fully-insulated bars including floor cover
- Installation of voltage transformers
 - Cast-resin insulated
 - 3 x 1-pole
 - Fixed-mounted, without primary fuses
 - Or withdrawable with primary fuses in a separate compartment, with bushings and shutters to the connection compartment for NXAIR ≤ 17.5 kV; for NXAIR 24 kV withdrawable with fuses
- Make-proof earthing switch
 - With manual operating mechanism, optionally motor operating mechanism
 - In addition to the standard interlock: Earthing switch optionally lockable or electromagnetically interlocked against the withdrawable switching device
- Endurance class for earthing switch: M0, E1
- Surge arrester or surge limiter
 - Surge arrester for protecting the switchgear against external overvoltages
 - Surge limiter for protecting consumers against switching overvoltages while operating motors with starting currents ≤ 600 A.



1) Available for NXAIR 24 kV in combination with withdrawable HV HRC fuses in the connection compartment as switch-fuse function for particularly high demands regarding switching capacity and switching rate.

Features

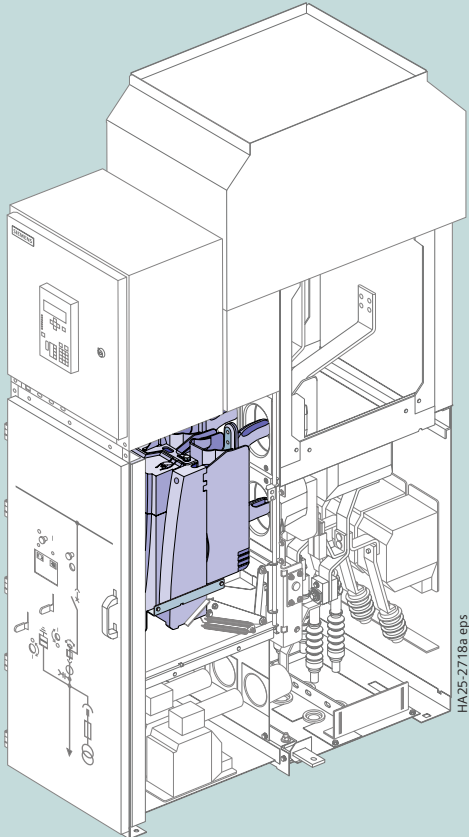
- According to IEC 62271-100, VDE 0671-100
- In NXAIR for 15 kV, 50 kA also available as generator circuit-breaker according to IEEE C37.013
- Suitable for all switching duties
- Stored-energy spring mechanism with motor operating mechanism, manual operation always possible
- Circuit-breaker also available in combination with withdrawable HV HRC fuses in the connection compartment as switch-fuse function for particularly high demands regarding switching capacity and switching rate, for NXAIR 24 kV
- Racking the circuit-breaker with manual operating mechanism, optionally with motor operating mechanism
- 64-pole low-voltage plug connector between circuit-breaker and fixed part
- Maintenance-free operating mechanisms under normal climatic conditions and for the max. permissible number of operating cycles.

SION vacuum circuit-breaker 3AE

Electrical data for	NXAIR ≤ 17.5 kV	NXAIR ≤ 17.5 kV	NXAIR 24 kV
Rated operating voltage	up to 17.5 kV	up to 17.5 kV	24 kV
Rated short-circuit breaking current	up to 40 kA	50 kA	up to 25 kA
Rated short-time withstand current	up to 40 kA/3 s	50 kA/3 s	up to 25 kA/3 s
Rated short-circuit making current	up to 100/104 kA	up to 125/130 kA	up to 63/65 kA
Rated peak withstand current	up to 100/104 kA	up to 125/130 kA ¹⁾	up to 63/65 kA
Rated normal current	up to 3150 A	up to 4000 A	up to 2500 A
Endurance class	E2, M2, C2	E2, M2, C2	E2, M2, C2

1) Max. 137 kA in combination with generator circuit-breaker according to IEEE C37.013

Components

Vacuum contactor

Features

- According to IEC 62271-106, VDE 0670-106
- Suitable for operating consumers with high switching rates
- Short-circuit protection via up to 2 HV HRC fuses connected in parallel
- Voltage supply of contactor coil via primary-fused control transformer or via external power supply
- Optional latching module for the contactor
- Racking the contactor via manual operating mechanism
- 64-pole low-voltage plug connector between contactor and fixed part
- Maintenance-free operating mechanisms under normal climatic conditions and for the max. permissible number of operating cycles
- Contact arms generally with silver-plated round contacts.

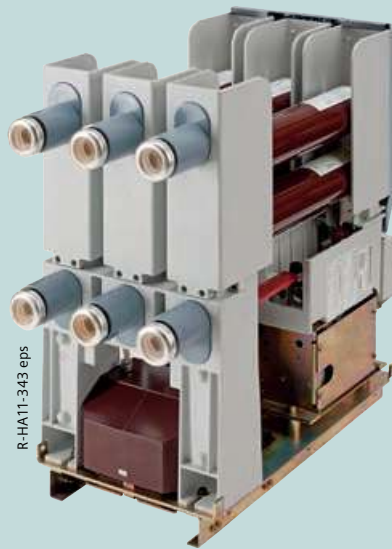

Contactor-fuse combination 3TL6

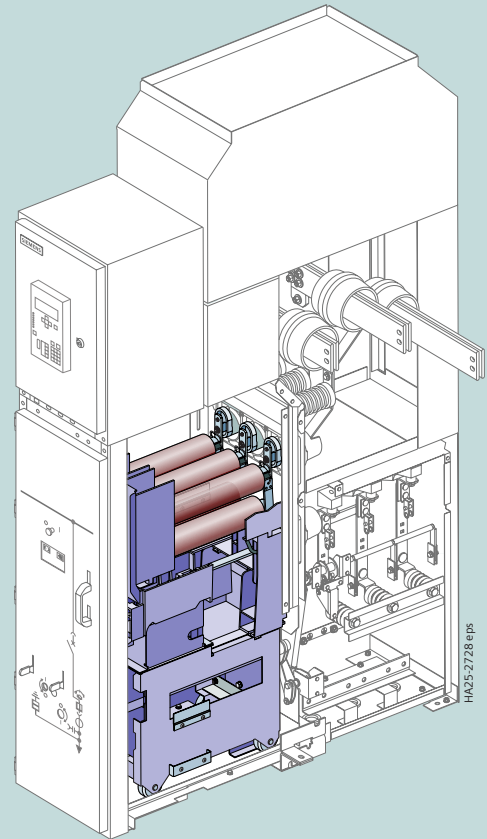

Withdrawable contactor 3TL6, HV HRC fuses and, if applicable, control transformer

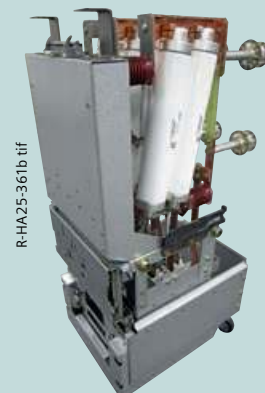

Withdrawable contactor 3TL8, HV HRC fuses and, if applicable, control transformer

Electrical data for	3TL6 in NXAIR	3TL8 in NXAIR
Rated operating voltage	bis 12 kV	up to 7.2 kV
Rated short-time withstand current ¹⁾	up to 8 kA	up to 8 kA
Rated normal current ²⁾	400 A	400 A
Number of operating cycles: of contactor, mechanical of interrupters, mechanical of contactor, electrical I_N	up to 1,000,000 up to 1,000,000 up to 1,000,000	up to 1,000,000 up to 250,000 up to 250,000

1) Can be used in switchgear with short-time withstand currents up to 50 kA due to the current limitation provided by HV HRC fuses.

2) Depending on the HV HRC fuses installed.

Features

- Inductive block-type current transformer principle according to IEC 61869-2, VDE 0414-9-2, standardized, available worldwide, or inductive bushing-type current transformer principle for the switch panel of NXAIR 24 kV according to the same IEC/VDE standards
 - Cast-resin insulated
 - Option: With coupling electrode for capacitive voltage detecting systems for bushing-type current transformers
 - Secondary multiratio possible
 - Current transformer certifiable
- Low-power principle for current measuring according to IEC 60044-7, VDE 0414-44-7 as option
 - Cast-resin insulated, in same housing as block-type current transformer, or as ring-core transformer
 - Secondary voltage: 225 V
 - Accuracy class up to 0.5 or 5P
 - Adjusted numerical protection, control and measuring relays are available
- Low-power principle for voltage measuring
 - Integrated in above housing
 - Combined with current measuring in low-power technology
 - For technical design, see page 16.



R-HA25-347 eps

Block-type current transformer up to 4000 A

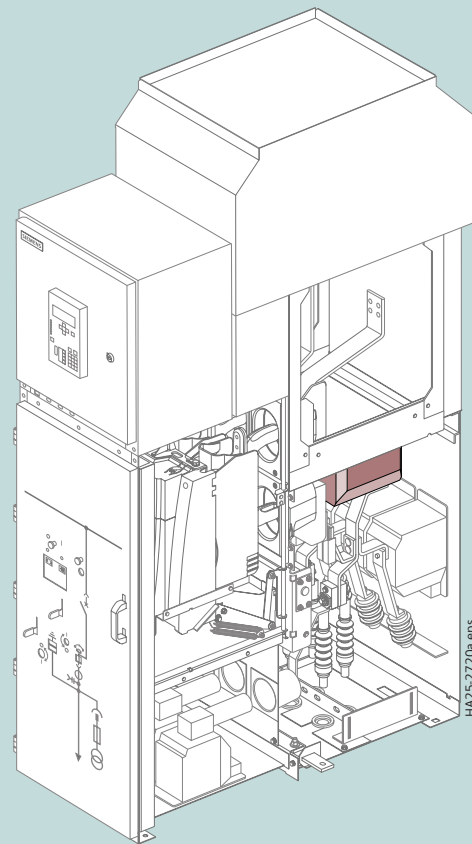

HA25-2720a eps

Electrical data for		
Operating voltage		up to 24 kV
Rated primary current		up to 4000 A
Short-time thermal current		up to 50 kA
Duration of short-time current		1 s or 3 s
Rated peak withstand current		up to 130 kA ¹⁾
Number of secondary cores		up to 3
Secondary current		1 A or 5 A
Accuracy classes	Measuring	0.2 – 1 FS5/FS10
	Protection	0.2 – 1 5P/10P
Rating		up to 30 VA

1) 137 kA, possible when combined with generator circuit-breakers

Components

Voltage transformers

Features

- Inductive principle according to IEC 61869-3, VDE 0414-9-3
 - Cast-resin insulated, single-pole
 - Option:
 - With earth-fault winding
 - Double-pole voltage transformer
- Low-power principle according to IEC 60044-8, VDE 0414-44-8
 - Integrated in current transformer housing, see page 15
 - Cast-resin insulated, single-pole
 - Constructional principle of resistive voltage divider
 - Adjusted numerical protection, control and measuring relays are available
 - Rated secondary voltage $3.25 \text{ V} / \sqrt{3}$
 - Accuracy class 0.5 or 3P.



Voltage transformer, fixed-mounted



Voltage transformer, withdrawable with primary fuses

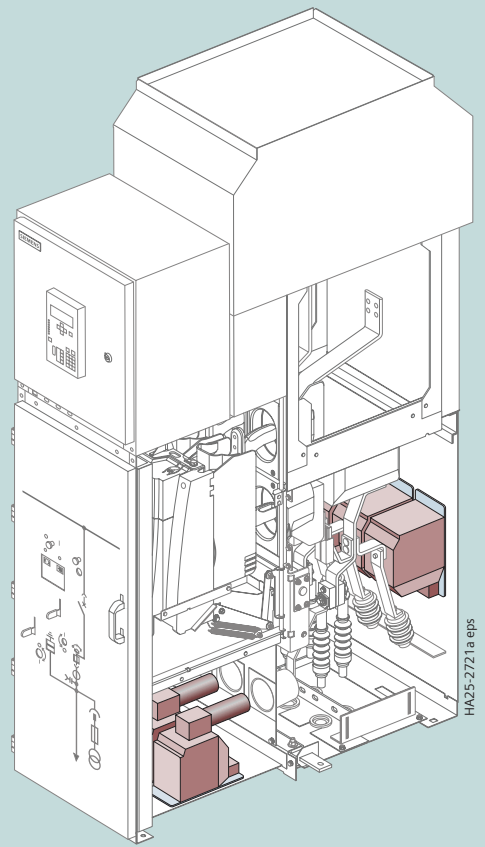

Electrical data for	
Primary operating voltage	up to 24 kV
Secondary operating voltage	up to 120 V or up to $120 \text{ V} / \sqrt{3}$
Accuracy classes	0.2/0.5/1.0
Rating	up to 200 VA

Features

- Low-voltage compartment for accommodation of all protection, control, measuring and metering equipment
- Partitioned safe-to-touch off the high-voltage part
- Low-voltage compartment can be removed, as all bus wires and control cables are plugged in
- Option: Test sockets for capacitive voltage detecting system at the feeders or the busbar
- Option: Higher low-voltage compartment
- Option: Separation wall from panel to panel
- Low-voltage cables are flexible and protected by metal covers
- Connection of withdrawable part and panel wiring to low-voltage compartment via 10-pole, coded plug connectors
- Bus wires are pluggable from panel to panel.

R-HA25-360 eps



Door of low-voltage compartment (example)

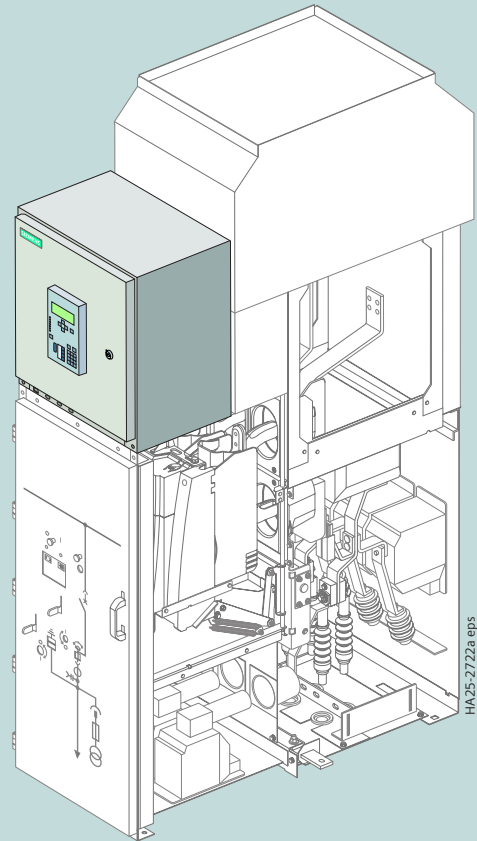

HA25-2722a eps

R-HA25-292a eps



Low-voltage compartment with built-in equipment (example)

Technical data 17.5 kV

Electrical data

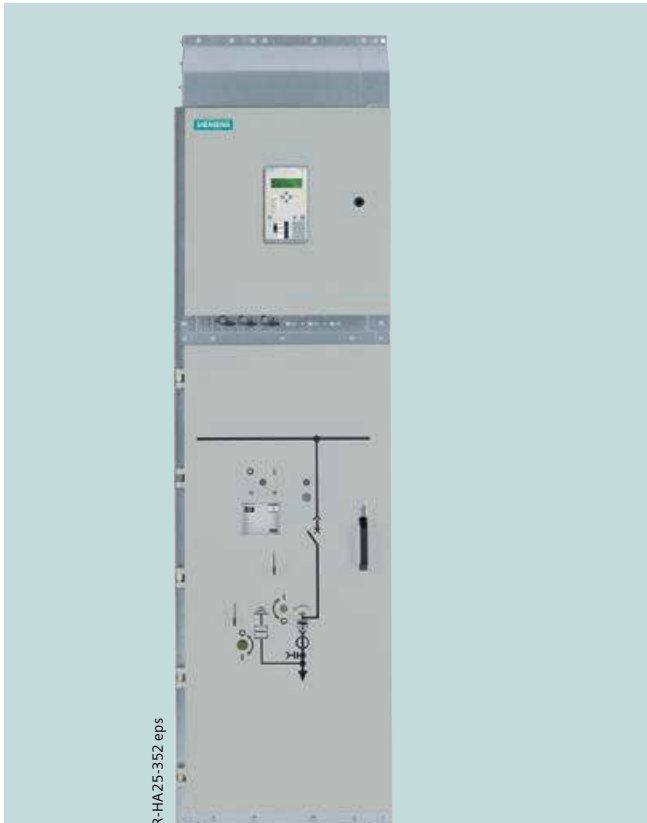

R-HA25-352 eps

Maximum values 17.5 kV; 40 kA; 4000 A

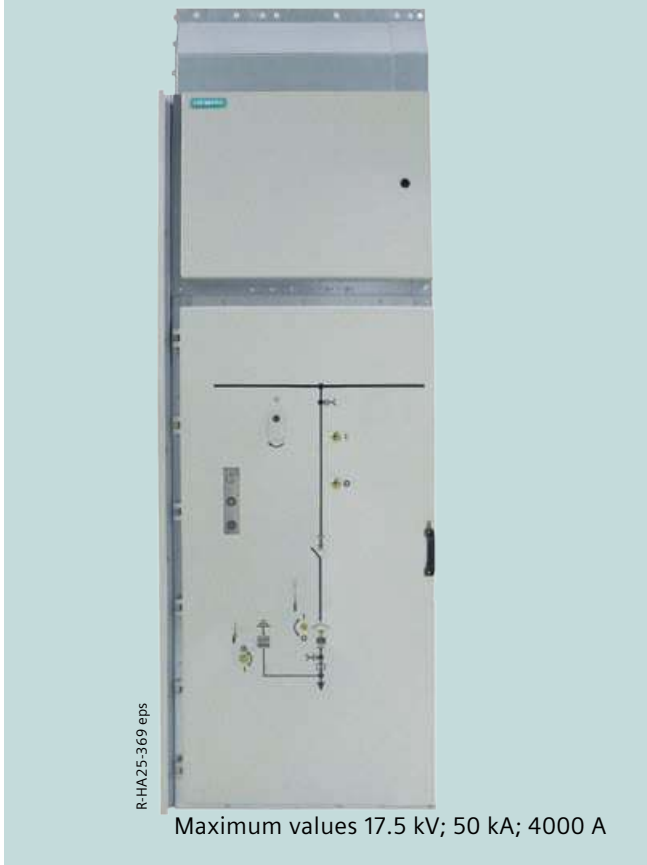

R-HA25-369 eps

Maximum values 17.5 kV; 50 kA; 4000 A

Rated values up to 40 kA

Rated				
voltage	kV	7.2	12	17.5
frequency	Hz	50/60	50/60	50/60
short-duration power-frequency withstand voltage (phase-to-phase, phase-to-earth)	kV	20 ¹⁾	28 ¹⁾	38
lightning impulse withstand voltage (phase-to-phase, phase-to-earth)	kV	60	75	95
short-circuit breaking current	max. kA	40	40	40
short-time withstand current, 3 s	max. kA	40	40	40
short-circuit making current ²⁾	max. kA	100/104	100/104	100/104
peak withstand current ²⁾	max. kA	100/104	100/104	100/104
normal current of busbar	max. A	4000	4000	4000
normal current of feeders:				
With circuit-breaker	max. A	4000	4000	4000
With contactor ³⁾	max. A	400	400	–
With disconnector link	max. A	4000	4000	4000
Bus sectionalizer	max. A	4000	4000	4000
Busbar connection panel	max. A	4000	4000	4000

Rated values 50 kA

Rated				
voltage	kV	7.2	12	17.5
frequency	Hz	50/60	50/60	50/60
short-duration power-frequency withstand voltage (phase-to-phase, phase-to-earth)	kV	20 ¹⁾	28 ¹⁾	38
lightning impulse withstand voltage (phase-to-phase, phase-to-earth)	kV	60	75	95
short-circuit breaking current	max. kA	50	50	50
short-time withstand current, 3 s	max. kA	50	50	50
short-circuit making current ²⁾	max. kA	125/130 137 ⁴⁾	125/130 137 ⁴⁾	125/130 137 ⁴⁾
peak withstand current ²⁾	max. kA	125/130 137 ⁴⁾	125/130 137 ⁴⁾	125/130 137 ⁴⁾
normal current of busbar	max. A	4000	4000	4000
normal current of feeders:				
With circuit-breaker	max. A	4000	4000	4000
With contactor ³⁾	max. A	400	400	–
With disconnector link	max. A	4000	4000	4000
Bus sectionalizer	max. A	4000	4000	4000
Busbar connection panel	max. A	4000	4000	4000

1) 32 kV or 42 kV optional for GOST standard

2) Values for 50 Hz: 100 kA or 125 kA
60 Hz: 104 kA or 130 kA

3) Current values dependent on HV HRC fuses, for GOST standard
max. 32 kV short-duration power-frequency withstand voltage

4) 137 kA in conjunction with 3AK7 generator circuit-breaker

Circuit-breaker panel

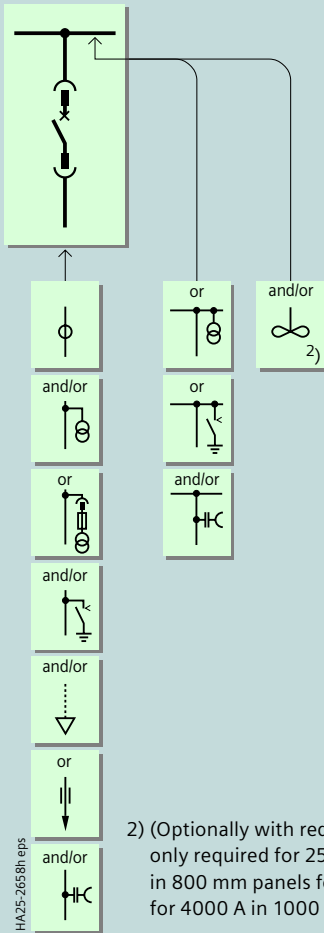

2) (Optionally with redundant fans) only required for 2500 A and 3150 A in 800 mm panels for 40 kA, or for 4000 A in 1000 mm panels.

Contactor panel

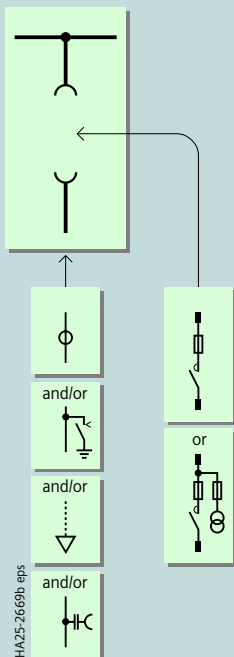

For other components in the busbar and connection compartments, see page 12.

Disconnecting panel

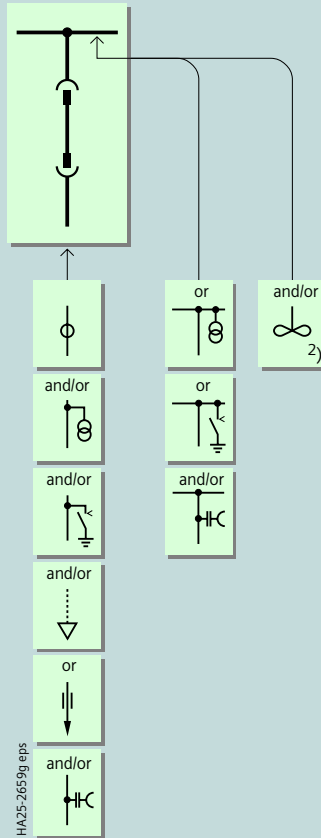

Metering panel

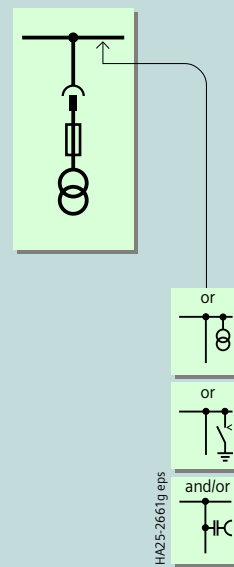

1) The details refer to conventional single-core sealing ends, and depend on the rated normal current and other built-in components.

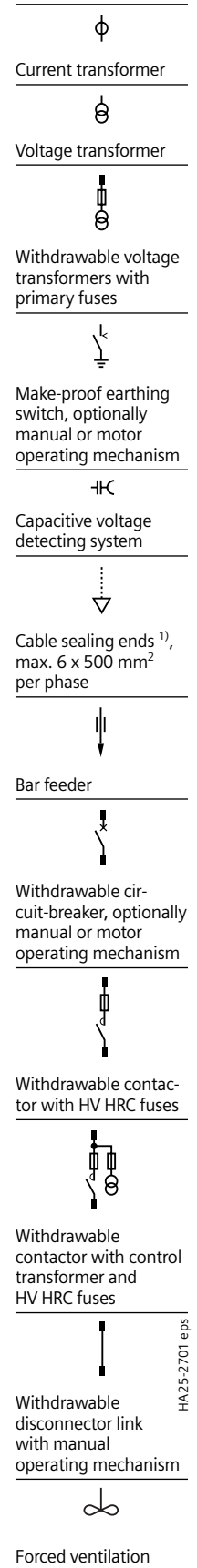

Technical data 17.5 kV

Product range, switchgear panels

Bus sectionalizer (mirror-image installation also possible)

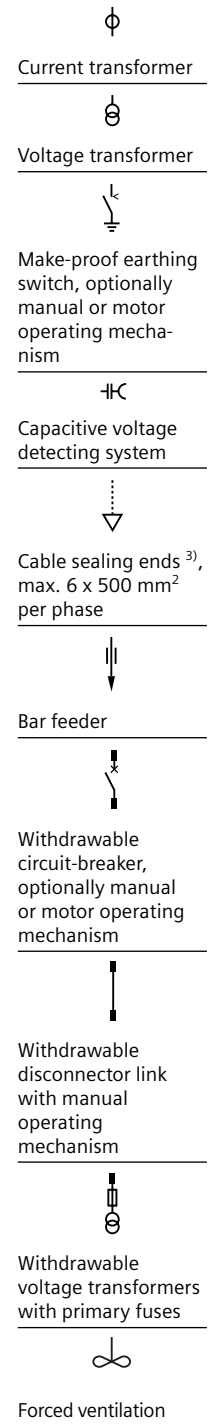
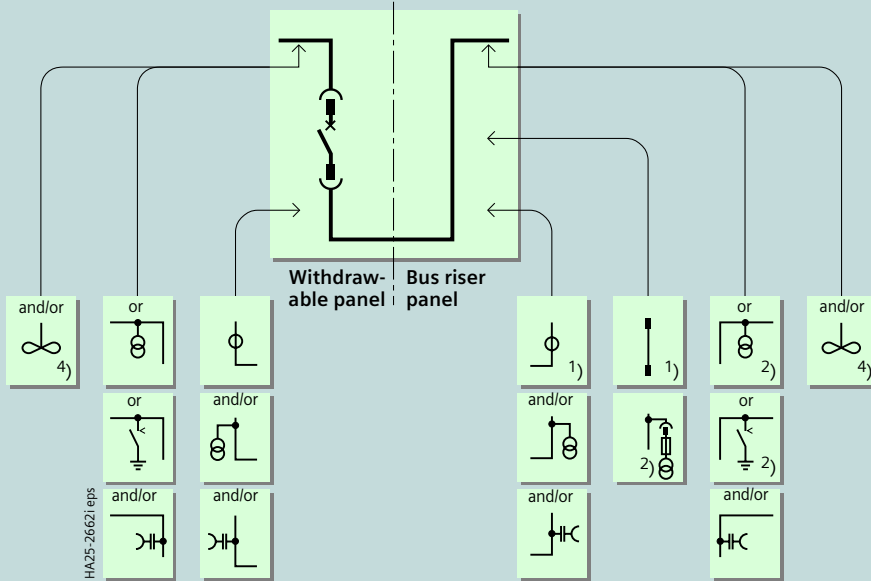

Busbar connection panel

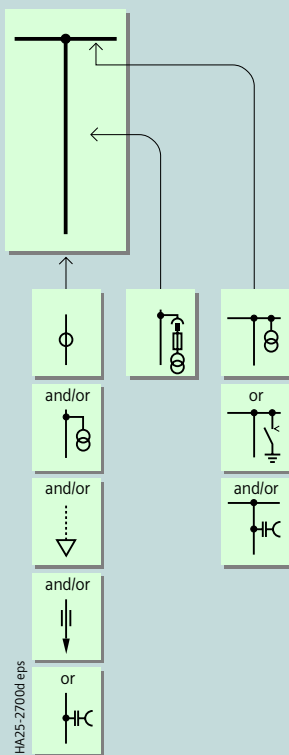

For other components in the busbar and connection compartments, see page 12.

- 1) Current transformers only possible in combination with withdrawable disconnecter link.
- 2) In case of withdrawable metering unit, voltage transformers and earthing switches on the busbar are not possible.
- 3) The details refer to conventional single-core sealing ends, and depend on the rated normal current and other built-in components.
- 4) (Optionally with redundant fans) only required for 2500 A and 3150 A in 800 mm panels for 40 kA, or for 4000 A in 1000 mm panels.

HA25-2701 eps

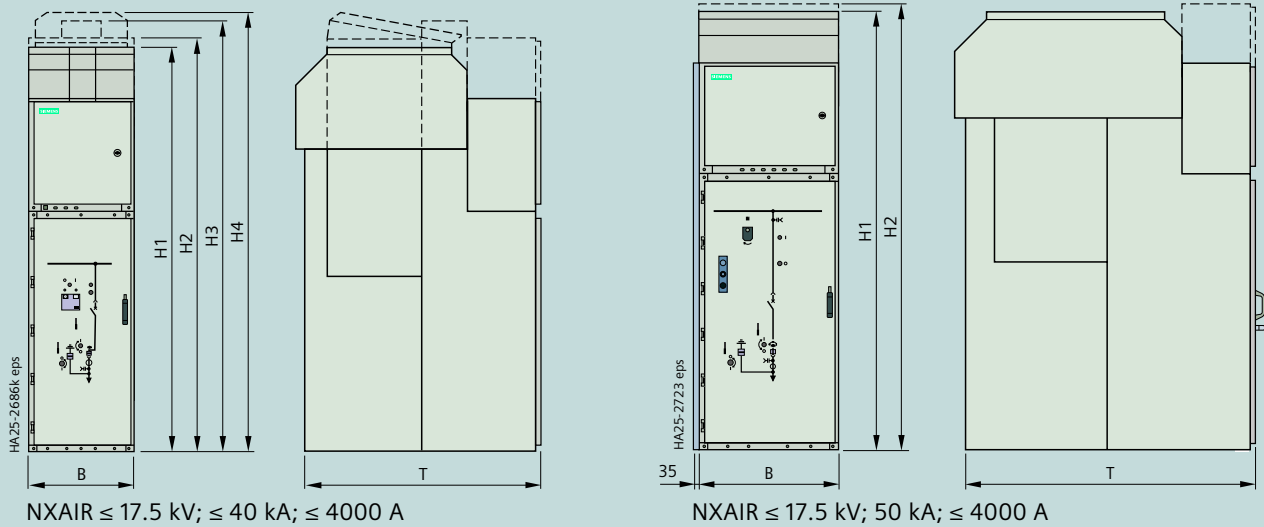

	Panel type	Rated normal current	Short-time withstand current		
			≤ 31.5 kA	40 kA	50 kA
Width in mm	Circuit-breaker panel, disconnecting panel	≤ 1000 A	600 ⁴⁾	–	–
		1250 A	800	800	800
		1600 A	800	–	800
		2000 A	800	800	–
		2500 A	1000	800/1000 ¹⁾	1000
Height in mm	Bus sectionalizer	1250 A	2 x 800	2 x 800	2 x 800
		≥ 2500 A	2 x 1000	2 x 1000 2 x 800 ²⁾	2 x 1000
		–	800	800	800
		–	435/600	435/600	435
		–	–	–	–
Height in mm	Standard panel or standard panel with natural ventilation	–	2300	2300	2500
		–	2350	2350	2550
		–	2450	2450	2650
		–	2500	2500	2680
Depth in mm	Single busbar, all panel types (except contactor panel)	–	1350 ⁵⁾	1500 ⁵⁾	1650
		–	1400	1500	1650

- 1) 800 mm with forced ventilation
- 2) Dependent on rated normal current and design of bus riser panel
- 3) Number of absorbers dependent on switchgear configuration
- 4) Disconnecting panel not in 600 mm
- 5) Panels with a rated normal current of 3150 A or 4000 A in 1540 mm depth

Technical data 17.5 kV

Room planning

Pressure relief out of the switchgear room through a pressure relief duct

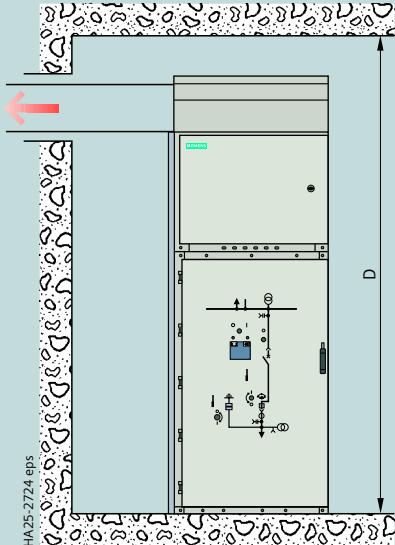

Lateral pressure relief duct

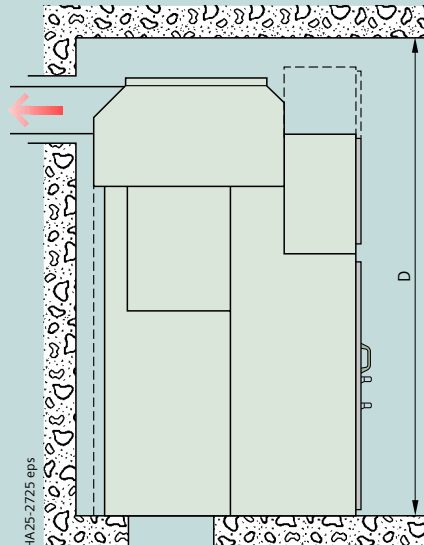

Rear pressure relief duct

Pressure relief into the switchgear room through absorbers

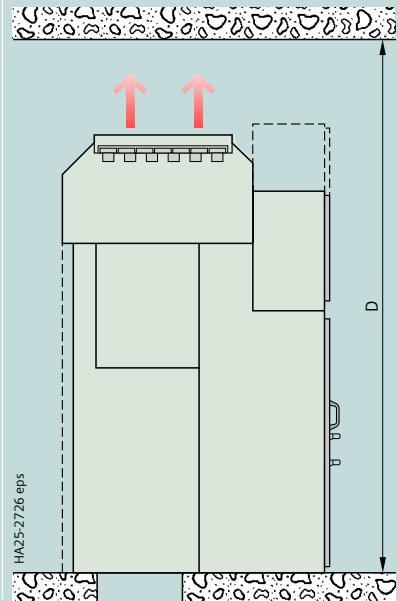

Type of pressure relief	Rated voltage	Ceiling height D in mm for short-circuit current			
		25 kA	31.5 kA	40 kA	50 kA
Pressure relief into the switchgear room through absorbers	12 kV	≥ 2800	≥ 3000	≥ 3500	≥ 3500
	17.5 kV	≥ 3500	≥ 3500	≥ 3500	≥ 3500
Pressure relief out of the switchgear room through a pressure relief duct	≤ 17.5 kV	≥ 2500	≥ 2500	≥ 2500	≥ 2700
Width of control aisle E (min.)	≤ 17.5 kV	1250	1250	1250	1350

Single-row arrangement (plan view) for single-busbar switchgear

For dimensions B (width) and T (depth), see table on page 21

For back-to-back and face-to-face arrangement, the room dimensions apply accordingly to those for single-row arrangement.

For back-to-back arrangement, a 1200 mm wide control aisle is required on the left or on the right of the switchgear.

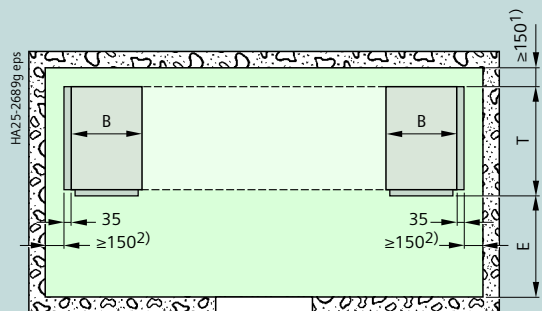

- 1) For connection from the front ≥ 150 mm, 100 mm for contactor panel; for connection from the rear ≥ 500 mm
- 2) For designs with a closed pressure relief duct to the outside, a distance of ≥ 500 mm is required on one side

Transport

NXAIR 17.5 kV switchgear is delivered in form of individual panels.

Please observe the following:

- Transport facilities on site
- Transport dimensions and transport weights
- Size of door openings in building.

Packing

Means of transport: Rail and truck

- Panels on pallets
- Open packing with PE protective foil.

Means of transport: Seafreight

- Panels on pallets
- Sealed in PE protective foil, with closed wooden crate
- With desiccant bags
- With sealed wooden base
- Max. storage time: 6 months.

Means of transport: Airfreight

- Panels on pallets
- In wooden latticed crate with sealed upper and lower PE protective foil.

These transport and packing stipulations apply to the complete NXAIR product family. More information to transport dimensions/transport weights is given in the corresponding table.

NXAIR up to 40 kA

Transport dimensions, transport weights ¹⁾ for individual panels			
Panel widths	Transport dimensions Width x Height x Depth	Transport weight	
		with packing	without packing
mm	mm x mm x mm	approx. kg	approx. kg
Transport by rail or truck			
1 x 435	800 x 2510 x 1610	800	770
1 x 600	800 x 2510 x 1610	980	950
1 x 800	1000 x 2510 x 1610	1240	1200
1 x 1000	1200 x 2510 x 1610	1390	1350
1 x 1000 ²⁾	1200 x 2510 x 1610	1690	1650
Transport by seafreight or airfreight			
1 x 435	820 x 2541 x 1830	900	770
1 x 600	820 x 2541 x 1830	1080	950
1 x 800	1020 x 2541 x 1830	1350	1200
1 x 1000	1220 x 2541 x 1830	1510	1350
1 x 1000 ²⁾	1220 x 2541 x 1830	1810	1650

NXAIR up to 50 kA

Transport dimensions, transport weights ¹⁾ for individual panels			
Panel widths	Transport dimensions Width x Height x Depth	Transport weight	
		with packing	without packing
mm	mm x mm x mm	approx. kg	approx. kg
Transport by rail or truck			
1 x 435	800 x 2650 x 1850	820	780
1 x 800	1000 x 2650 x 1850	1400	1350
1 x 1000	1200 x 2650 x 1850	1460	1400
1 x 1000 ²⁾	1200 x 2650 x 1850	1760	1700
Transport by seafreight or airfreight			
1 x 435	822 x 2676 x 1872	930	780
1 x 800	1022 x 2676 x 1872	1520	1350
1 x 1000	1222 x 2676 x 1872	1580	1400
1 x 1000 ²⁾	1222 x 2676 x 1872	1880	1700

1) Average values depending on the degree to which panels are equipped

2) 4000 A panels (with forced ventilation) and 3150 A panels

Technical data 24 kV

Electrical data

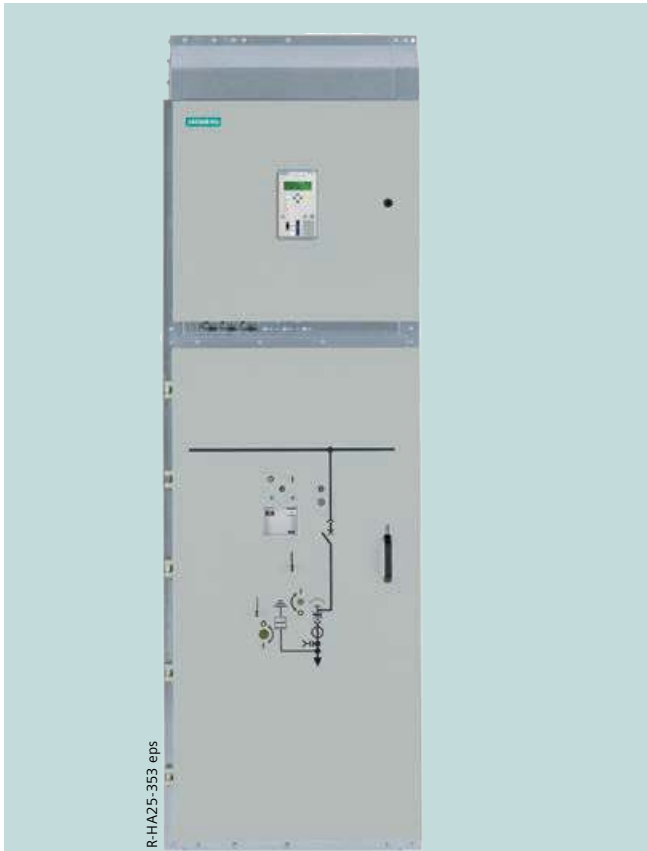

Maximum values 24 kV; 25 kA; 2500 A



Motor-operated panel

Rated values

Rated		
voltage	kV	24
frequency	Hz	50/60
short-duration power-frequency withstand voltage (phase-to-phase, phase-to-earth)	kV	50 ¹⁾
lightning impulse withstand voltage (phase-to-phase, phase-to-earth)	kV	125
short-circuit breaking current	max. kA	25
short-time withstand current, 3 s	max. kA	25
short-circuit making current ²⁾	max. kA	63/65
peak withstand current ²⁾	max. kA	63/65
normal current of busbar	max. A	2500
normal current of feeders:		
With circuit-breaker	max. A	2500
With withdrawable disconnecter link	max. A	2500
Bus sectionalizer	max. A	2500

1) 65 kV optional for GOST standard

2) Values for 50 Hz: 63 kA, 60 Hz: 65 kA

Circuit-breaker panel

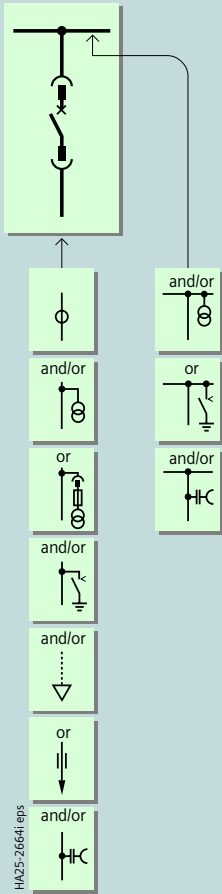

Metering panel

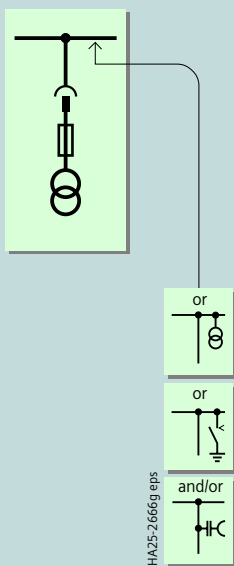

1) The details refer to conventional single-core sealing ends, and depend on the rated normal current and other built-in components.

Disconnecting panel

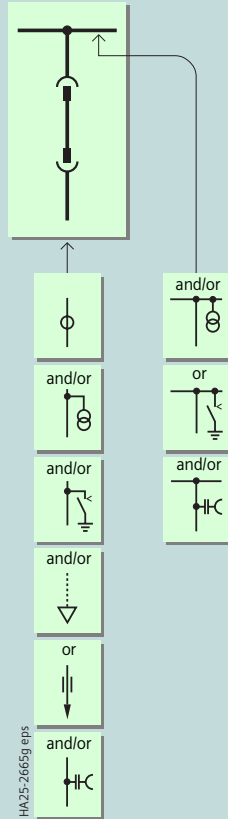

Switch panel

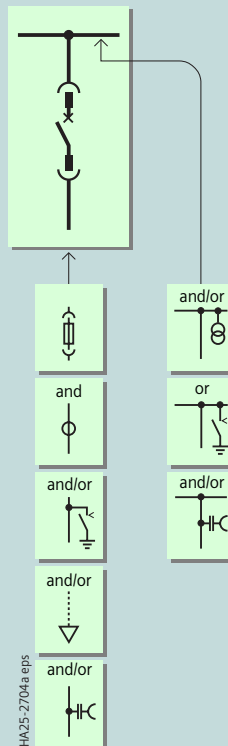

For other components in the busbar and connection compartments, see page 12.

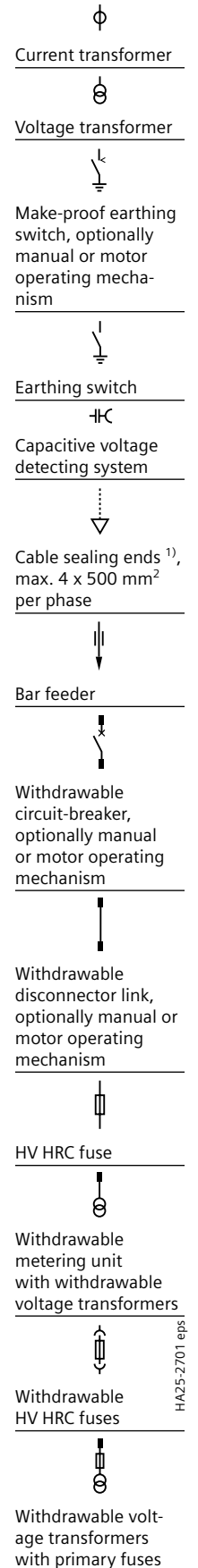

Technical data 24 kV

Product range, switchgear panels

Bus sectionalizer (mirror-image installation also possible)

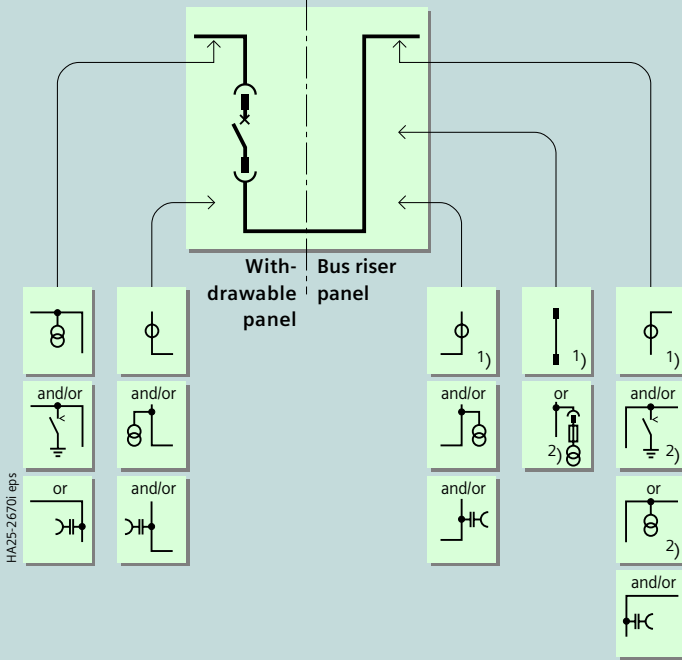

Double busbar (back-to-back arrangement)

Circuit-breaker panel (incoming sectionalizer)

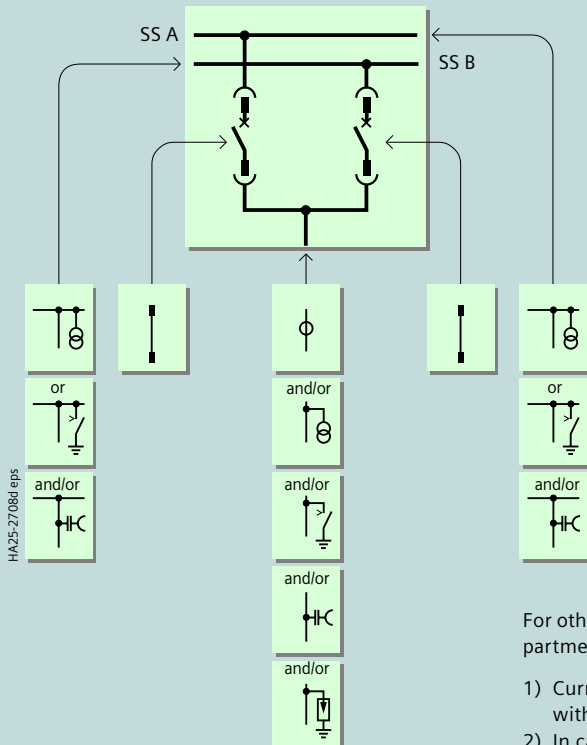

Bus coupler

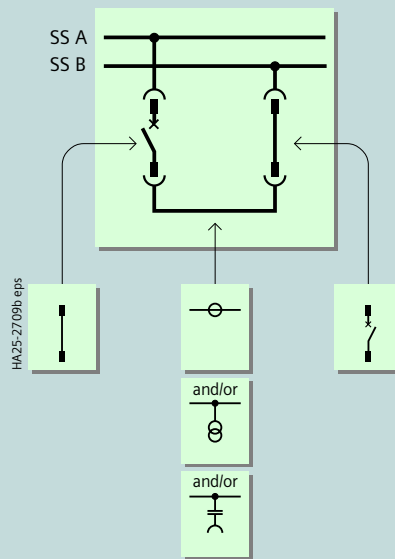

For other components in the busbar and connection compartments, see page 12.

- 1) Current transformers only possible in combination with withdrawable disconnecter link.
- 2) In case of withdrawable metering unit, voltage transformers and earthing switches on the busbar are not possible.

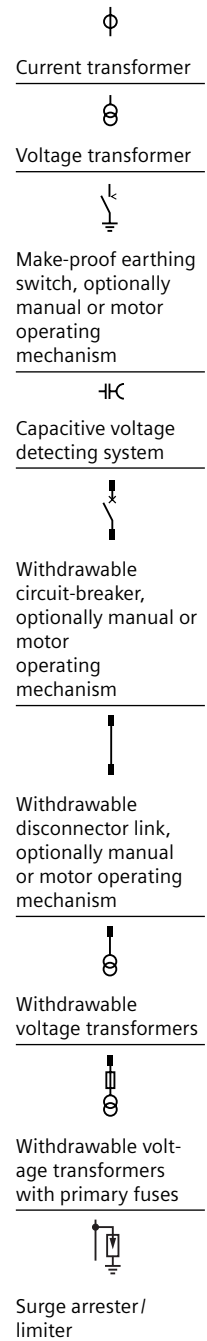

SS A = Busbar A
SS B = Busbar B

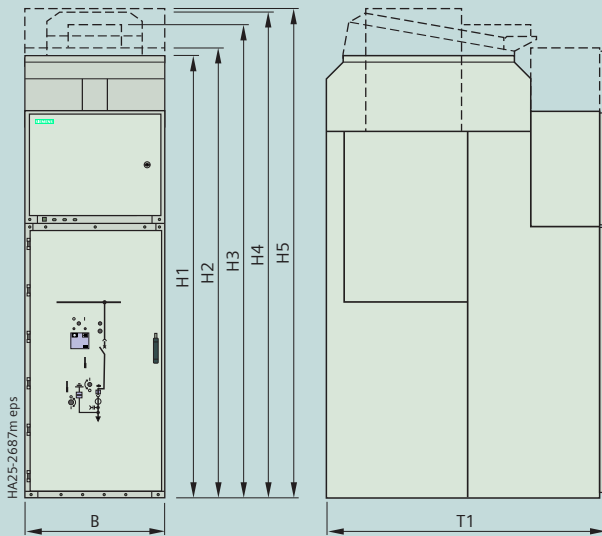

Single busbar

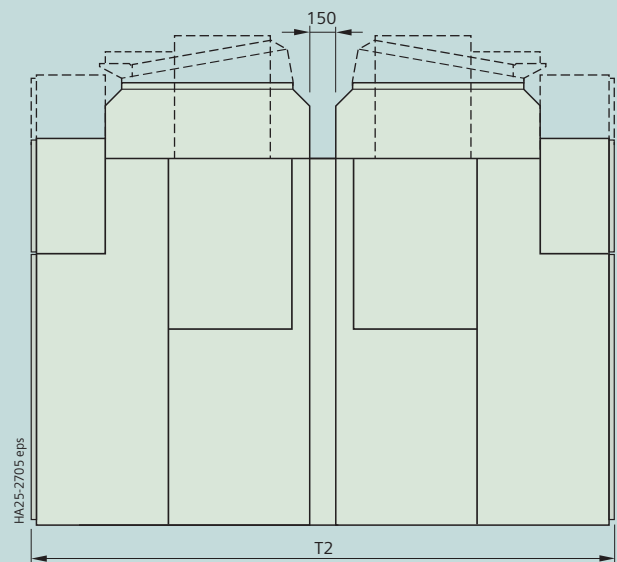

Double busbar (back-to-back arrangement)

	Panel type	Rated normal current	Short-time withstand current		
			16 kA	20 kA	25 kA
Width in mm	B	Circuit-breaker panel, disconnecting panel	800 A	800	800
		1250 A	800	800	
		2000 A	1000	1000	
		2500 A	1000	1000	
	Bus sectionalizer	1250 A ≤ 2500 A	2 x 800 2 x 1000	2 x 800 2 x 1000	
	Metering panel	–	800	800	
	Switch-disconnector panel with HV HRC fuses				
Height in mm	H1	Standard panel		2510	2510
	H2	With high low-voltage compartment		2550	2550
	H3	With natural ventilation		2680	2680
	H4	With optional arc absorber ¹⁾		2750	2750
	H5	With additional compartment for busbar components		2770	2770
Depth in mm	T1	Single busbar		1600	1600
	T2	Double busbar		3350	3350

1) Number of absorbers dependent on switchgear configuration

Technical data 24 kV

Room planning

Pressure relief out of the switchgear room through a pressure relief duct

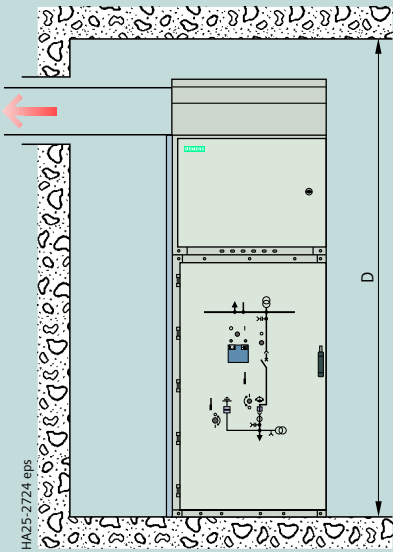

Lateral pressure relief duct

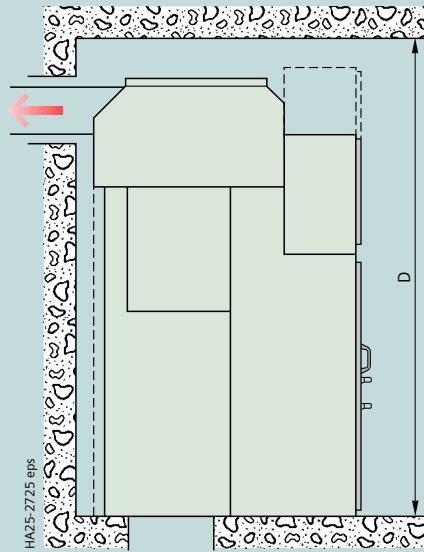

Rear pressure relief duct

Pressure relief into the switchgear room through absorbers

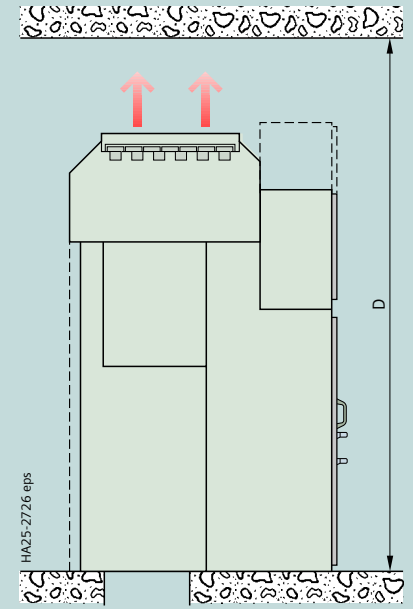

Type of pressure relief	Ceiling height D in mm for short-circuit current
	≤ 25 kA
Pressure relief into the switchgear room through absorbers	≥ 3300
Pressure relief out of the switchgear room through a pressure relief duct	≥ 3000 ³⁾

NXAIR 24 kV

Arrangement (top view)
for single-busbar switchgear

For dimensions B (width) and T (depth), see table on page 27

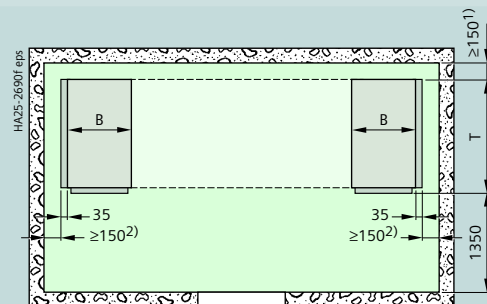

Double-busbar arrangement (top view)

For back-to-back arrangement, a 1200 mm wide control aisle is required on the left or on the right of the switchgear to have the possibility (if required) to bring a circuit-breaker from one row to the other.

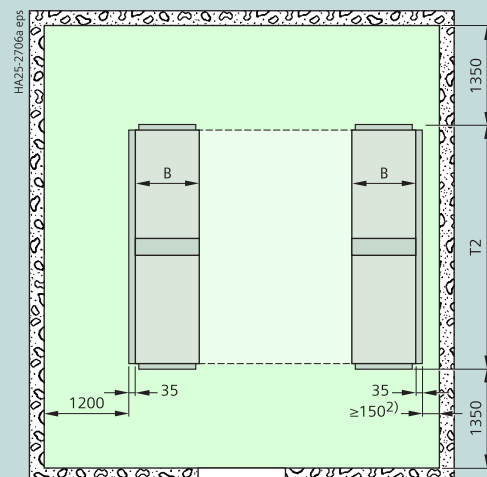

- 1) For connection from the front ≥ 150 mm
for connection from the rear ≥ 500 mm
- 2) For designs with a closed pressure relief duct to the outside,
a distance of ≥ 500 mm is required on one side
- 3) In case of a lower ceiling height, please contact your Siemens partner

Transport

NXAIR 24 kV switchgear is delivered in form of individual panels.

Please observe the following:

- Transport facilities on site
- Transport dimensions and transport weights
- Size of door openings in building.

Packing

Means of transport: Rail and truck

- Panels on pallets
- Open packing with PE protective foil.

Means of transport: Seafreight

- Panels on pallets
- Sealed in PE protective foil, with closed wooden crate
- With desiccant bags
- With sealed wooden base
- Max. storage time: 6 months.

Means of transport: Airfreight

- Panels on pallets
- In wooden latticed crate with sealed upper and lower PE protective foil.

These transport and packing stipulations apply to the complete NXAIR product family. More information to transport dimensions/transport weights is given in the corresponding table.

Transport dimensions, transport weights ¹⁾ for individual panels ²⁾			
Panel widths	Transport dimensions Width x Height x Depth	Transport weight	
		with packing approx. kg	without packing approx. kg
mm	mm x mm x mm		
Transport by rail or truck			
1 x 800	1200 x 2980 ⁴⁾ x 1810	1340	1200
1 x 1000	1200 x 2980 ⁴⁾ x 1810	1440	1400
Transport by seafreight or airfreight ³⁾			
1 x 800	1200 x 2500 x 2000	1410	1250
1 x 1000	1200 x 2500 x 2000	1410	1250

1) Average values depending on the degree to which panels are equipped

2) The double-busbar panels (back-to-back arrangement) are delivered as individual panels. Back-to-back connection is done on site

3) Pressure relief ducts or busbar components such as earthing switches or voltage transformers as separate delivery for 10 panels each (W 1100 x H 2000 x D 1800)

4) A height of 2450 mm is possible if the pressure relief duct is transported as a separate delivery

Standards

Standards, specifications, guidelines

Type of service location

The switchgear can be used as indoor installation according to IEC 61936 (Power Installations exceeding AC 1 kV) and VDE 0101

- Outside lockable electrical service locations at places which are not accessible to the public. Enclosures of switchgear can only be removed with tools
- In lockable electrical service locations. A lockable electrical service location is a place outdoors or indoors that is reserved exclusively for housing electrical equipment and which is kept under lock and key. Access is restricted to authorized personnel and persons who have been properly instructed in electrical engineering. Untrained or unskilled persons may only enter under the supervision of authorized personnel or properly instructed persons.

Dielectric strength

- The dielectric strength is verified by testing the switchgear with rated values of short-duration power-frequency withstand voltage and lightning impulse withstand voltage according to IEC 62271-1/VDE 0671-1 (see table "Dielectric strength").
- The rated values are referred to sea level and to normal atmospheric conditions (1013 hPa, 20 °C, 11g/m³ water content according to VDE 0111 and IEC 60071).
- The dielectric strength decreases with increasing altitude. For site altitudes above 1000 m (above sea level) the standards do not provide any guidelines for the insulation rating, but leave this to the scope of special agreements.
- Site altitude
 - As the altitude increases, the dielectric strength of insulation in air decreases due to the decreasing air density. This reduction is permitted up to a site altitude of 1000 m according to IEC and VDE.
 - For site altitudes above 1000 m, a higher insulation level must be selected. It results from the multiplication of the rated insulation level for 0 to 1000 m with the altitude correction factor K_a .

Standards

The switchgear complies with the relevant standards and specifications applicable at the time of type tests.

In accordance with the harmonization agreement reached by the countries of the European Union, their national specifications conform to the IEC standard.

Table – Dielectric strength

Rated voltage (r.m.s. value)	kV	7.2	12	15	17.5	24
Rated short-duration power-frequency withstand voltage (r.m.s. value)						
– Between phases and to earth	kV	20	28	36	38	50
– Across isolating distances	kV	23	32	40	45	60
Rated lightning impulse withstand voltage (peak value)						
– Between phases and to earth	kV	60	75	95	95	125
– Across isolating distances	kV	70	85	105	110	145

Altitude correction factor K_a

For site altitudes above 1000 m, the altitude correction factor K_a is recommended, depending on the site altitude above sea level.

Rated short-duration power-frequency withstand voltage to be selected for site altitudes > 1000 m
 \geq Rated short-duration power-frequency withstand voltage up to $\leq 1000 \text{ m} \cdot K_a$

Rated lightning impulse withstand voltage to be selected for site altitudes > 1000 m
 \geq Rated lightning impulse withstand voltage up to $\leq 1000 \text{ m} \cdot K_a$

Example:
 3000 m site altitude above sea level,
 17.5 kV switchgear rated voltage,
 95 kV rated lightning impulse withstand voltage
 Rated lightning impulse withstand voltage to be selected =
 $95 \text{ kV} \cdot 1.28 = 122 \text{ kV}$

Result:
 According to the above table, a switchgear for a rated voltage of 24 kV with a rated lightning impulse withstand voltage of 125 kV is to be selected.

Overview of standards (May 2016)

		IEC standard	VDE standard	DIN EN standard
Switchgear	NXAIR	IEC 62271-1	VDE 0671-1	DIN EN 62271-1
		IEC 62271-200	VDE 0671-200	DIN EN 62271-200
Devices	Circuit-breakers	IEC 62271-100	VDE 0671-100	DIN EN 62271-100
	Vacuum contactors	IEC 62271-106	VDE 0671-106	DIN EN 62271-106
	Disconnectors and earthing switches	IEC 62271-102	VDE 0671-102	DIN EN 62271-102
	Switch-disconnectors	IEC 62271-103	VDE 0671-103	DIN EN 62271-103
	Switch-disconnector/fuse combination	IEC 62271-105	VDE 0671-105	DIN EN 62271-105
	HV HRC fuses	IEC 60282-1	VDE 0670-4	DIN EN 60282-1
	Voltage detecting systems	IEC 61243-5	VDE 0682-415	DIN EN 61243-5
Degree of protection	–	IEC 60529	VDE 0470-1	DIN EN 60529
Insulation	–	IEC 60071	VDE 0111	DIN EN 60071
Instrument transformers	–	IEC 61869-1	VDE 0414-9-1	DIN EN 61869-1
	Current transformers	IEC 61869-2	VDE 0414-9-2	DIN EN 61869-2
	Voltage transformers	IEC 61869-3	VDE 0414-9-3	DIN EN 61869-3
Installation, erection	–	IEC 61936-1	VDE 0101-1	DIN EN 61936-1

Current carrying capacity

- According to IEC 62271-1/VDE 0671-1 and IEC 62271-200/VDE 0671-200, the rated normal current refers to the following ambient air temperatures:
 - Maximum of 24-hour mean: + 35 °C
 - Maximum: + 40 °C
- The rated normal current of the panels and busbars depends on the ambient air temperature outside the enclosure.

Protection against solid foreign objects, electric shock and water

NXAIR fulfills according to the standards

- IEC 62271-200
- IEC 60529
- VDE 0470-1
- VDE 0671-200

the following degrees of protection:

Switchgear panel	NXAIR ≤ 17.5 kV	NXAIR 24 kV
Degree of protection for the enclosure optionally	IP3XD IP4X, IP50, IP51	IP3XD IP4X IP50, IP51
Degree of protection for the enclosure with ventilation	IP3XD IP4X	IP3XD IP4X
Degree of protection for the partitions	IP2X	IP2X
Degree of protection for the enclosure against mechanical impacts from outside	IK07	IK07

Climate and environmental influences

NXAIR switchgear is suitable for application in indoor installations under normal operating conditions as defined in IEC 62271-1, as follows:

- Maximum value of ambient air temperature: + 40 °C, of 24-hour mean: + 35 °C
- Minimum value of ambient air temperature: –5 °C
- Site altitude ≤ 1000 m above sea level
- Relative air humidity over 24 h: ≤ 95 %, over a month: ≤ 90 %
- No significant pollution of the ambient air (dust, gases, vapors, salts).

The switchgear may be used, subject to possible additional measures, under the following additional environmental influences:

- Natural foreign materials
- Chemically active pollutants
- Small animals

and the climate classes:

- 3K3
- 3K5.

The climate classes are defined according to IEC 60721-3-3.

Seismic withstand capability

NXAIR ≤ 17.5 kV and NXAIR 24 kV switchgear is tested in accordance with the following internationally accepted requirements: IEC/TS 62271-210, IEC 60068-3-3, IEC 60068-2-6, IEEE 693, UBC Division IV.

Internal arc classification

- Protection of operating personnel by means of tests for verifying the internal arc classification
- Internal arcing tests must be performed in accordance with IEC 62271-200/VDE 0671-200
- The switchgear complies with all criteria specified in the a.m. standards (page 30) for the basic version up to 50 kA.
- NXAIR complies with the internal arc classification: IAC A FLR up to 50 kA, 1 s. This provides maximum personal safety for switchgear accessible from all sides.
- Definition of criteria:
 - Criterion 1
Correctly secured doors and covers do not open, limited deformations are accepted
 - Criterion 2
No fragmentation of the enclosure, no projection of small parts above 60 g
 - Criterion 3
No holes in accessible sides up to a height of 2 m
 - Criterion 4
No ignition of indicators due to hot gases
 - Criterion 5
The enclosure remains connected to its earthing point.
- Beyond the specifications of the above-mentioned standards, NXAIR switchgear up to 31.5 kA/1 s resp. 40 kA/0.1 s is optionally designed with confinement of internal arcs to the respective compartment.

Terms

“Make-proof earthing switches” are earthing switches with short-circuit making capacity according to

- IEC 62271-102 and
- VDE 0671-102/EN 62271-102.

Published by
Siemens AG 2016

Siemens AG
Energy Management
Medium Voltage & Systems
Mozartstraße 31 C
91052 Erlangen
Germany

Siemens AG
Energy Management
Medium Voltage & Systems
160 Herring Road
2113 Macquarie Park NSW
Australia

Siemens AG
Energy Management
Medium Voltage & Systems
Thane Belapur Road
40061 Thane
India

Siemens AG
Energy Management
Medium Voltage & Systems
Jalan Pulo MAS Utara Kav. B 67-68
Jakarta, 13210
Indonesia

Siemens AG
Energy Management
Medium Voltage & Systems
46 Newmarket Road
Randburg 2169
South Africa

For further information please contact
our Customer Support Center
Phone: +49 180 524 70 00
Fax: +49 180 524 24 71
E-mail: support.energy@siemens.com

Article No. EMMS-K1425-A811-B3-7600
Printed in Germany
Dispo 30400
PU 14000/79905 KG 05.16 1.0

Subject to changes and errors. The information
given in this document only contains general
descriptions and/or performance features which
may not always specifically reflect those described,
or which may undergo modification in the course
of further development of the products.

The requested performance features are binding
only when they are expressly agreed upon in the
concluded contract.

NXAIR and SION are registered trademarks of
Siemens AG. Any unauthorized use is prohibited.
All other designations in this document may
represent trademarks whose use by third parties
for their own purposes may violate the proprietary
rights of the owner.

