

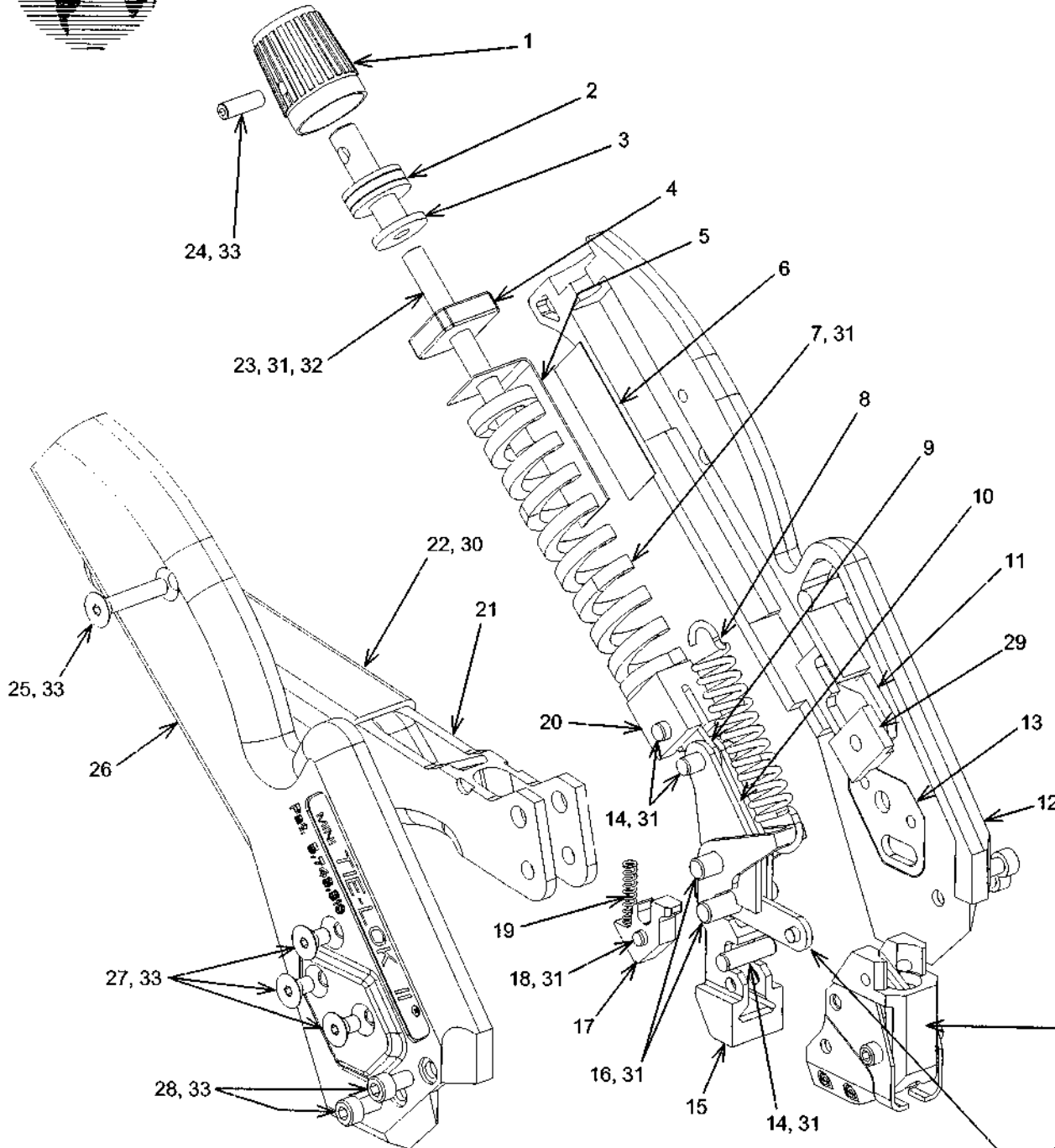

BAND-IT[®]
THE CLAMPING EXPERTS

Repair Parts List

A91079 Mini Tie-Lok II Tool



Item	Band-It #	Qty	Description
1	M53387	1	Knob, adjustment
2	M53287	1	Bearing, thrust (3 pieces)
3	A92577	1	Cap, tension
4	A93487	1	Block, tension
5	A93587	1	Indicator, tension
6	A92387	1	Decal, tension indicator
7	A91687	1	Spring, die
8	A91787	1	Spring, extension
9	A95487	1	Link, tension
10	A92267	2	Arm, tension
11	A95387	2	Plate, tension
12	K93487	1	Body, left, black
13	A91477	2	Plate, body
14	A73587	3	Pin, dowel, 5/32 x 9/16 lg
15	A91387	1	Lever, pull-up, front load
16	A94887	2	Pin, straight, 3/16 x .780 lg
17	A91187	1	Gripper, pull
18	K97487	1	Pin, .125 x .313 lg
19	A93887	1	Spring, 1/8 x 5/8, 25#
20	A92487	1	Plunger, tension
21	K97587	1	Handle
22	M50287	1	Grip, textured, red
23	A94488	1	Screw, set, #10-24 x 2.00 lg
24	A85687	1	Screw, set, #6-32 x 7/16 lg
25	A96087	1	Screw, flt-hd, #6-32 x 3/4 lg
26	K93587	1	Body, right, black
27	A91987	6	Screw, flt-hd, #6-32 x 1/4 lg
28	M54587	4	Screw, cap, #6-32 x 1/4 lg
29	K57887	2	Pad, centering
30	-	-	Adhesive, cyanoacrylate
31	-	-	Grease, extreme pressure
32	-	-	Red Loctite (high strength)
33	-	-	Blue Loctite (med. strength)

See list of tool head parts on reverse side

cut-off link and pin shown as a reference from reverse side



BAND-IT[®]
THE CLAMPING EXPERTS

Repair Parts List A91079 Mini Tie-Lok II Tool

Partial view of pull-up lever and spring shown as a reference from previous page

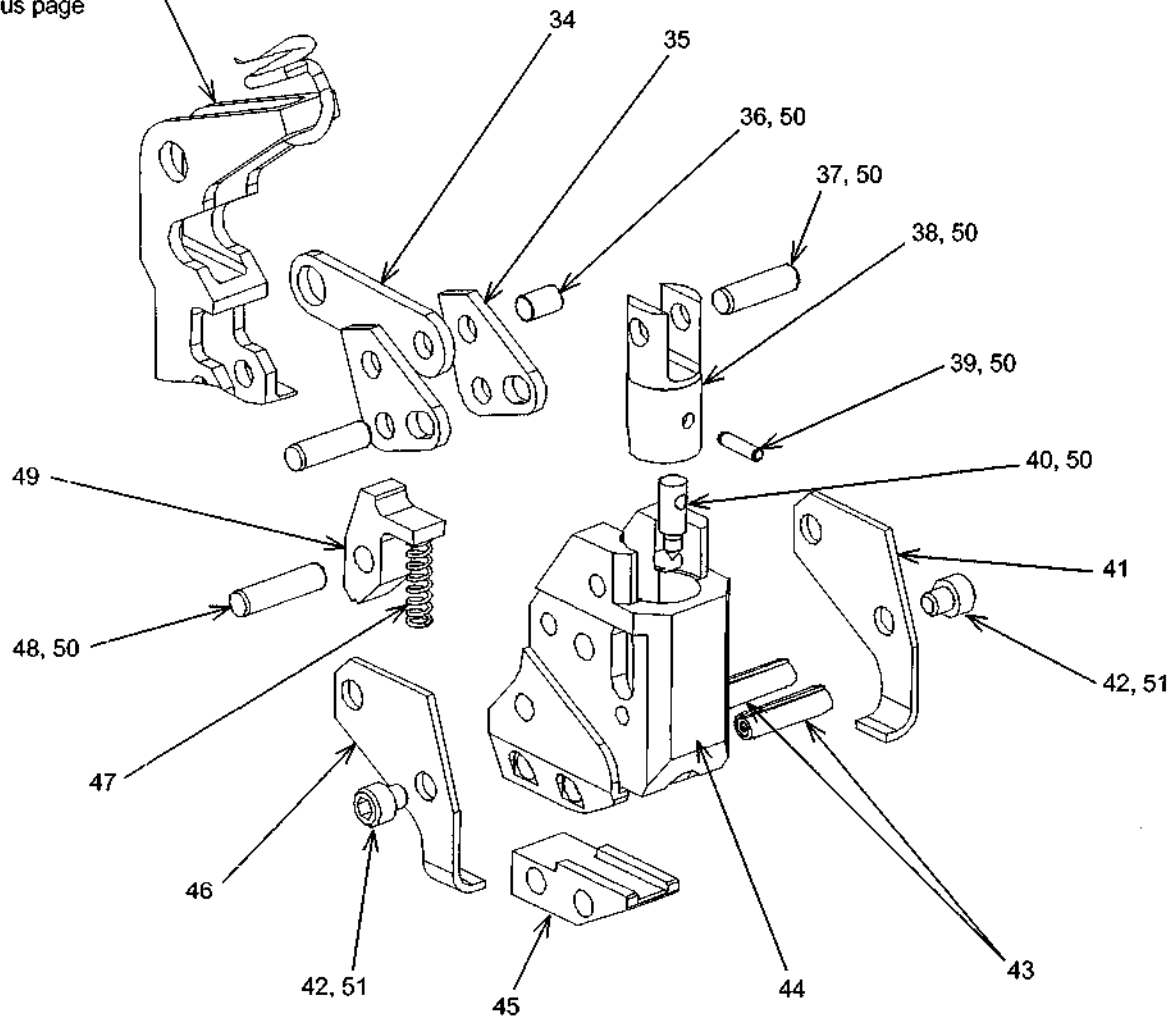

Item	Band-It #	Qty	Description
34	A92177	1	Link, cut-off
35	A94987	2	Lever, cut-off
36	A94687	1	Pin, straight, 1/8 x 3/16 lg
37	M01887	2	Pin, dowel, 1/8 x 7/16 lg
38	A97187	1	Knife, Tie-Lok II
39	A94587	1	Pin, dowel, 1/16 x 1/4 lg
40	A91887	1	Dimple punch
41	A95187	1	Clip, left
42	A49787	2	Screw, cap, #4-40 x 1/8
43	A90987	2	Pin, Spirol, 1/8 x 1/2 lg
44	A92677	1	Tool head
45	A92887	1	Blade, Mini Tie-Lok II
46	A95287	1	Clip, right
47	C09587	1	Spring, 1/8 x 1/2, 13#
48	A84487	1	Pin, dowel, 1/8 x 1/2 lg
49	A91287	1	Gripper, hold
50	-	-	Grease, extreme pressure
51	-	-	Blue Loctite (med. strength)



BAND-IT[®]
THE CLAMPING EXPERTS

Operating Instructions A91079 Mini Tie-Lok II Tool

Warning:

Always wear safety glasses when operating hand tool.

Instructions:

1. Turn tension adjustment knob until desired tension setting is displayed in tension indicator window. Space between numbers counts as one-half setting. See step 6.
2. Extend handle open to release gripping mechanism and insert clamp tail into tool through front load entry.
3. Squeeze handle repeatedly to tighten band around object. Be sure to release handle completely to use full pull-up stroke of tool. Buckle must be secure against the tool head and nestled between the two retention clips. Once the preset tension has been reached, the handle will no longer release completely.
4. To cut-off excess clamp tail, squeeze handle one last time.
5. The tool must be reset by, extending the handle out until it snaps into place, the tool will be ready to apply the next clamp.
6. Tension Setting Range:

.177 Smooth I.D. Mini Tie-Lok 0 – 8

