



MIMOX SURGE DIVERTERS TYPE SVL

INTRODUCTION

Surge diverters type SVL have been designed specifically for use in switching applications where the surge to be suppressed may have a fast rise time but a low energy content.



Each diverter consists of a number of metal oxide varistors, connected in series and encapsulated in a PVC container using a polyurethane resin. Dimensions of the diverters can be seen in Figure 1.

APPLICATIONS

The metal oxide varistors have highly non-linear volt-amp characteristics and therefore provide excellent protection against overvoltages. This type of diverter is recommended for use with any device where impulse withstand level is low and high energy absorption is not required.

Such applications may include:

- The protection of transformers where the frequency of switching is high, particularly if the transformers are lightly loaded
- The protection of motors, especially if there is a likelihood of switching in the stalled or accelerating condition

TERMINATIONS

Surge diverters type SVL are available in two formats:

- The standard format has an M6 ISO coarse thread at each end
- The flying lead version has one M6 stud connection and an insulated 0.5m or 2m long flexible lead to aid installation

SELECTION BY VOLTAGE

The diverters are available with maximum voltage ratings from 1.2 to 15.5kV rms and can be connected either between the supply lines or between each supply line and earth. Selection must be based on the maximum voltage that may be impressed on the diverter during both normal and abnormal system conditions.

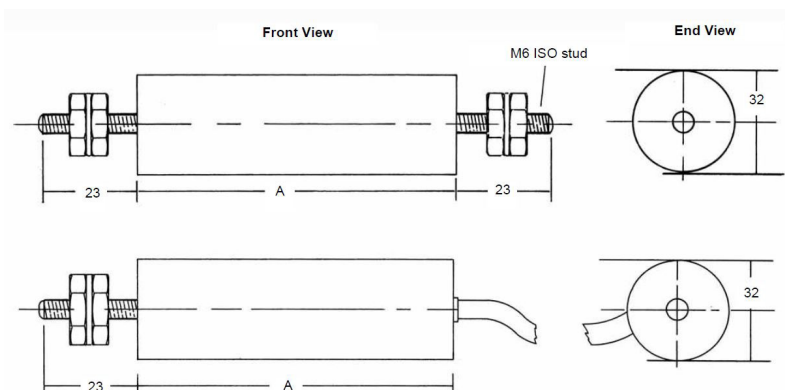

Figure 1 - Design and Dimensions (mm) for Standard Format and Flying Lead SVL Surge Diverters

Refer to Table 1 Overleaf for Type Specific Dimensions for Body Length A



MIMOX SURGE DIVERTERS TYPE SVL

SELECTION BY VOLTAGE CONTINUED...

This voltage will depend on the system earthing arrangement and must not exceed the maximum diverter rated voltage as shown in Table 1.

SPEED OF RESPONSE

The response time of the metal oxide elements to transient overvoltages is of the order of 50 nanoseconds.

OPERATING TEMPERATURE RANGE

The diverters are rated for ambient temperatures up to 70°C.

MAINTENANCE

No maintenance is necessary on SVL diverters. It is recommended that diverters be replaced when the main operational components of the switchgear are changed or if there has been some severely abnormal switching condition or switchgear failure.

CURRENT AND ENERGY RATINGS

Metal oxide varistors (MOVs) have to be de-rated from their published figures according to the number and size of the current surges expected during the required lifetime of the device. SVL surge diverters contain MOVs, but they have been chosen so that, for the application for which they have been designed, de-rating is not normally a consideration. For SVL diverter applications outside the current and energy rating parameters indicated in Table 1 below, please contact our technical team.

All properties quoted in this table are typical values and do not constitute a specification

| Type | Body Length A | Maximum Diverter Rated Voltage | Maximum Surge Protection Level at 10A Discharge | Maximum System Voltage L-L | | Current Rating 8/20 μs Waveform** | Energy Rating 8/20 μs Waveform** |
|-------|---------------|--------------------------------|---|---|--|-----------------------------------|----------------------------------|
| | | | | Diverter connected L-N system effectively earthed as defined below* | Diverter connected L-N system non-effectively earthed (or L-L) | | |
| | mm | kVrms | kVpk | kVrms | kVrms | A | J |
| SVL1 | 50 | 1.2 | 4 | 1.5 | 1.2 | 150 | 11 |
| SVL2 | 60 | 2.4 | 7 | 3 | 2.4 | 150 | 21 |
| SVL3 | 75 | 3 | 8.5 | 3.75 | 3 | 150 | 27 |
| SVL4 | 110 | 4 | 11.5 | 5 | 4 | 150 | 38 |
| SVL6 | 110 | 6 | 16.5 | 7.5 | 6 | 150 | 54 |
| SVL8 | 160 | 8 | 22.5 | 10 | 8 | 150 | 75 |
| SVL9 | 160 | 9.5 | 27 | 12 | 9.5 | 150 | 86 |
| SVL10 | 200 | 10.5 | 30 | 13.5 | 10.5 | 150 | 97 |
| SVL12 | 200 | 12 | 33 | 15 | 12 | 150 | 108 |
| SVL15 | 240 | 15.5 | 43.5 | 19 | 15.5 | 150 | 140 |

Table 1 - Performance and Selection

* The coefficient of earthing of a three phase system is defined as follows: "The ratio of the highest rms voltage to earth of the sound phase or phases at the point of application of a diverter during a line-to earth fault (irrespective of the fault location), to the highest line-to-line rms voltage, expressed as a percentage of the latter voltage. If this ratio is less than 80%, then the system is regarded as effectively earthed. If the ratio is greater than 80%, then the system is regarded as non-effectively earthed."

** Based on 10,000 surge events.



**THORNE &
DERRICK
INTERNATIONAL**

Thorne & Derrick
+44 (0) 191 410 4292
www.powerandcables.com