



THORNE &
DERRICK
INTERNATIONAL

Thorne & Derrick
+44 (0) 191 410 4292
www.powerandcables.com

EUROMOLD®

INTERFACE E - 5/8"
MEDIUM VOLTAGE SEPARABLE
CONNECTORS AND BUSHINGS

CATALOGUE 2022



 **Nexans**
ELECTRIFY THE FUTURE

COMPANY PRESENTATION

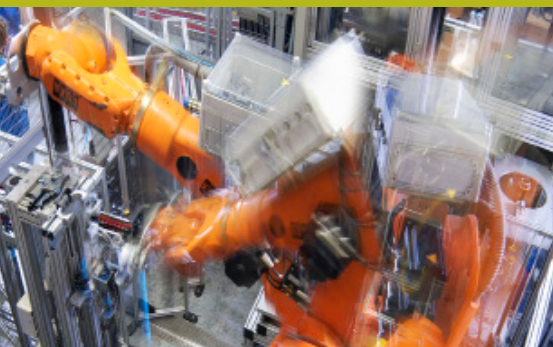

EUROMOLD

Euromold is the leading European specialised designer, manufacturer and distributor of prefabricated cable accessories for medium voltage energy distribution. Euromold provides a complete range of accessories for underground cables: premoulded EPDM rubber connectors for cables and epoxy bushings for transformers and switchgear, as well as a large range of cold-shrinkable terminations and joints from 12 to 42 kV.

Euromold is also the manufacturer of electrical components for the high voltage accessories of the Nexans group.

ISO 9001 Certificate

Since 1992, Euromold's commitment to quality is demonstrated by its ISO 9001 certification.

International standards

All our products meet the International standards like CENELEC HD 629.1, CENELEC EN 50180, IEC 60137, IEC 60502-4... or country specifications. Official certificates, CESI, KEMA, ATEX... prove the conformity of our products. Long duration tests of existing or new products are continuously performed in our test fields.

Laboratory accreditation

Since June 2000, Euromold's independent ELAB laboratory obtained the BELAC accreditation no.144-TEST conform with the European standards for laboratories ISO 17025 for electrical testing of low and medium voltage cable accessories according to the international standards EN 50393, IEC 60502-4, IEC 61442 and HD 629.



While every care is taken to ensure that the information contained in this publication is correct, no legal responsibility can be accepted for any inaccuracy. Nexans Network Solutions N.V. - Div. Euromold reserves the right to alter or modify the characteristics of its products described in this catalogue as standards and technology evolve.

SEPARABLE CONNECTORS AND BUSHINGS

INTERFACE E - 5/8"

TABLE OF CONTENTS

- 784TB - tee connector
- 800PB-58 - coupling connector
- 804PB-58 - coupling connector
- 800SA-58 - surge arrester
- 750S1, 775S1 & 775T1 - equipment bushing
- Accessories
- Possible arrangements

INTERFACE E - 5/8"

Dimensions according to IEEE std. 386 (in mm, except where noted).

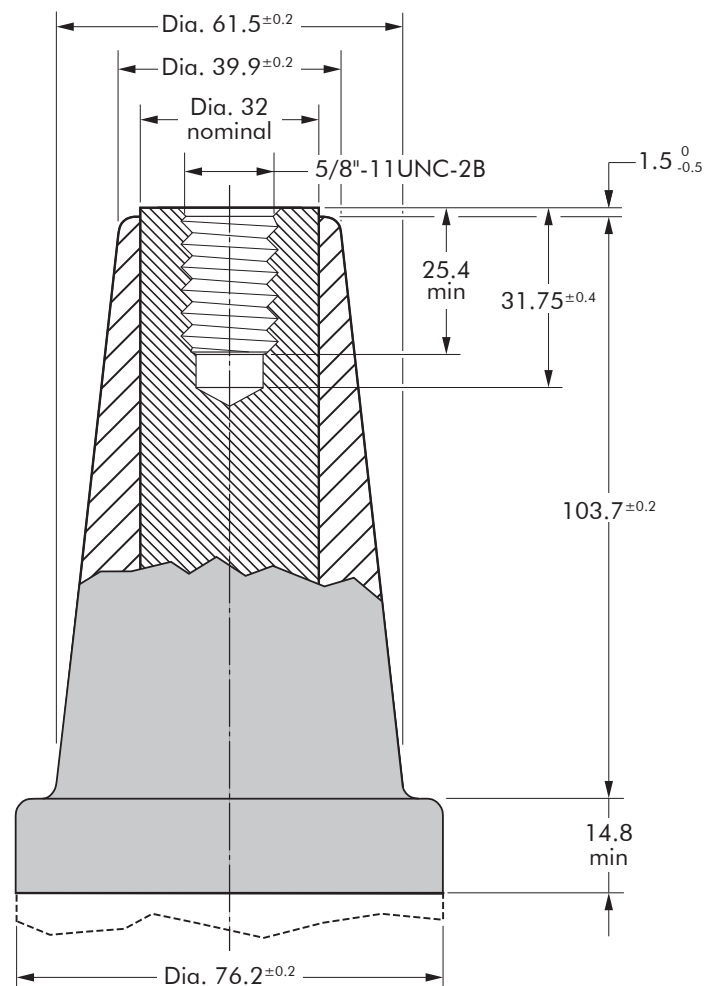

In mm.

CONNECTING POSSIBILITIES

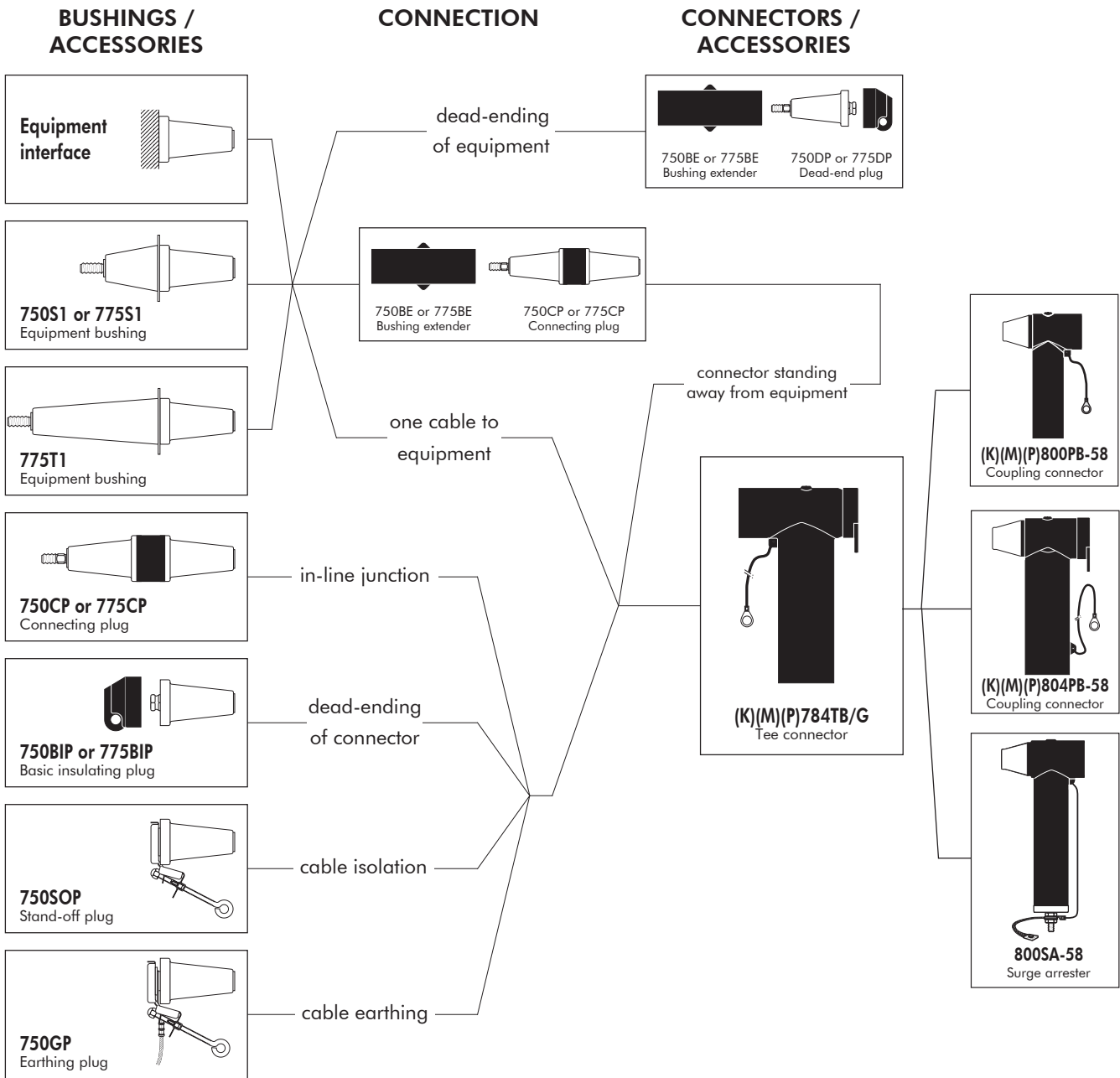

APPLICATION

Separable tee shape connector (bolted type) designed to connect polymeric insulated cable to equipment (transformers, switchgear, motors, ...). Also connects cable to cable when using the appropriate mating parts.

TECHNICAL CHARACTERISTICS

- The thick conductive EPDM jacket provides a total safe to touch screen which ensures safety for personnel.
- Each separable connector is tested for AC withstand and partial discharge prior to leaving the factory.



DESIGN

Separable connector comprising:

1. Conductive EPDM insert.
2. Conductive EPDM jacket.
3. Insulating EPDM layer moulded between the insert and the jacket.
4. Type E 5/8" interface as described by IEEE 386.
5. Conductor contact.
6. Basic insulating plug 858 BIPA (with VD point).
7. Cable reducer.
8. Conductive rubber cap.
9. Stud+flange nut 5/8".
10. Earthing lead.

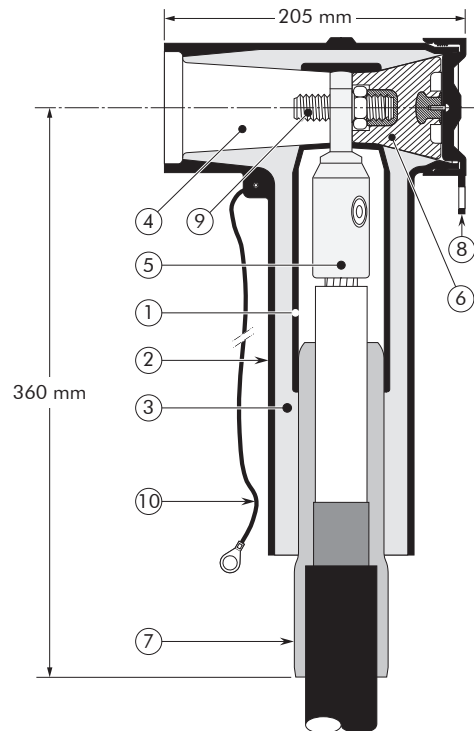

6/10 (12) kV
 6.35/11 (12) kV
 8.7/15 (17.5) kV
 12/20 (24) kV
 12.7/22 (24) kV
 18/30 (36) kV
 19/33 (36) kV
 20.8/36 (42) kV

Up to 42 kV
 Up to 800 A

EUROMOLD®

The screen break design enables cable outer sheath testing without removing or dismantling the connector.

SPECIFICATIONS AND STANDARDS

The 784TB separable connector meets the requirements of CENELEC HD 629.1.

Separable connector type	Voltage U_m (kV)	Current I_r (A) When installed on an appropriate equipment bushing	Conductor sizes (mm ²)	
			min	max
784TB/G	12	800	50	630
K784TB/G	24	800	35	630
M784TB/G	36	800	35	630
P784TB/G	42	800	35	630

01/2022

KIT CONTENTS

The complete (K)(M)(P)784TB/G tee connector kit comprises 3x the following components:

The kit also comprises silicone grease, field control mastic, gloves, wipers, roll adhesive tape, installation instructions, venting rod and crimp chart.

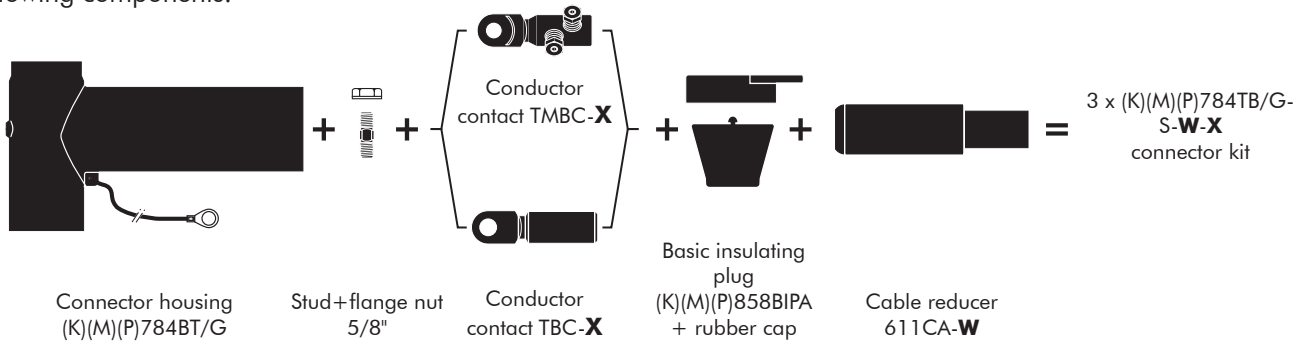

ORDERING INSTRUCTIONS

To order the tee connector, select the ordering part number which gives you the best centring of your core insulation diameter and substitute **X** using table X, according to your conductor size and type. Add a 'K' for use up to 24 kV, add an 'M' for use up to 36 kV, add a 'P' for use up to 42 kV.

EXAMPLE:

The copper wire screened cable is 36 kV, 240 mm² stranded aluminium with a diameter over core insulation of 37.0 mm. Order 3 x M784TB/G-S-32-240AL2.

TABLE W

Ordering part number	Dia. over core insulation (mm)	
	min	max
3 x 784TB/G-S-15-X	16.0	22.0
3 x 784TB/G-S-19-X	20.0	26.5
3 x 784TB/G-S-22-X	23.5	31.0
3 x 784TB/G-S-27-X	28.5	37.5
3 x 784TB/G-S-32-X	34.0	42.5
3 x 784TB/G-S-37-X	39.0	48.5
3 x 784TB/G-S-43-X	45.5	56.0

TABLE X

Conductor sizes (mm ²)	Aluminium conductor		Aluminium and copper conductor	Copper conductor
	DIN hexagonal	Deep indent	Bolted	DIN hexagonal
35	35AL2	35AL1		35UN2
50	50AL2	50AL1		50UN2
70	70AL2	70AL1		70UN2
95	95AL2	95AL1		95UN2
120	120AL2	120AL1		120UN2
150	150AL2	150AL1		150UN2
185	185AL2	185AL1		185UN2
240	240AL2	240AL1		240UN2
300	300AL2	300AL1		300UN2
400	400AL2	400AL1		400UN2
500	500AL2	500AL1		500UN2
630	630AL2	630AL1		630UN2

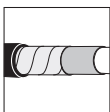

For use with copper tape screened cables. Order: Kit MT.



For use in potentially explosive atmospheres (for 12 kV max.). Order: -/ATEX.



For use with other cable types. Please contact our representative.



For applications outdoors and in humid climate. Order: +MWS.



Components can be ordered individually.

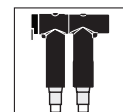

Multiple cable arrangement possible. Please contact our representative.

APPLICATION

Separable tee shape connector (bolted type) designed to connect polymeric insulated cable to equipment (transformers, switchgear, motors, ...). Also connects cable to cable when using the appropriate mating parts.

TECHNICAL CHARACTERISTICS

- The thick conductive EPDM jacket provides a total safe to touch screen which ensures safety for personnel.
- Each separable connector is tested for AC withstand and partial discharge prior to leaving the factory.



DESIGN

Separable connector comprising:

1. Conductive EPDM insert.
2. Conductive EPDM jacket.
3. Insulating EPDM layer moulded between the insert and the jacket.
4. Type E 5/8" interface as described by IEEE 386.
5. Conductor contact.
6. Basic insulating plug 858 BIPA (with VD point).
7. Cable reducer.
8. Conductive rubber cap.
9. Stud+flange nut 5/8".
10. Earthing lead.

The screen break design enables cable outer sheath testing without removing or dismantling the connector.

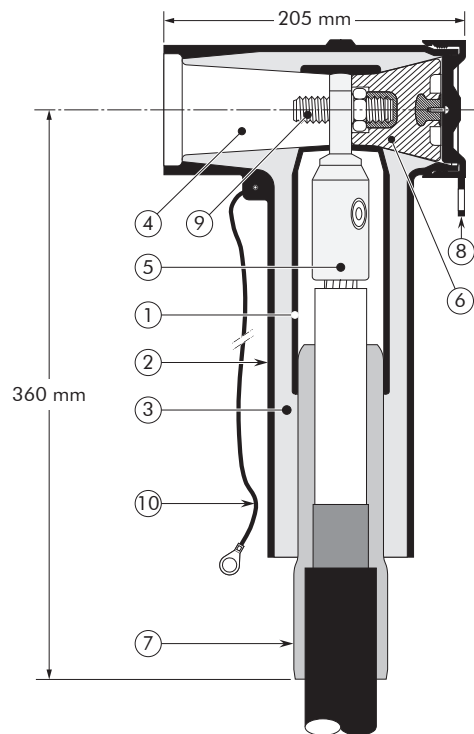

6/10 (12) kV
6.35/11 (12) kV
8.7/15 (17.5) kV
12/20 (24) kV
12.7/22 (24) kV
18/30 (36) kV
19/33 (36) kV
20.8/36 (42) kV

Up to 42 kV
Up to 1250 A

EUROMOLD®

SPECIFICATIONS AND STANDARDS

The 784TB separable connector meets the requirements of CENELEC HD 629.1.

Separable connector type	Voltage U_m (kV)	Current I_r (A) When installed on an appropriate equipment bushing	Conductor sizes (mm ²)	
			min	max
784TB/G	12	1250	50	630
K784TB/G	24	1250	35	630
M784TB/G	36	1250	35	630
P784TB/G	42	1250	35	630

01/2022

KIT CONTENTS

The complete (K)(M)(P)784TB/G tee connector kit comprises 3x the following components:

The kit also comprises silicone grease, field control mastic, gloves, wipers, roll adhesive tape, installation instructions, venting rod and crimp chart.

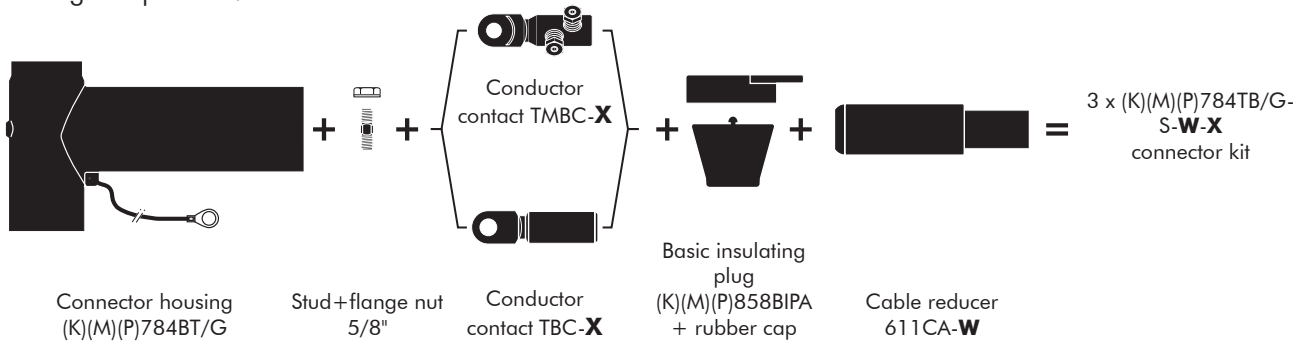

ORDERING INSTRUCTIONS

To order the tee connector, select the ordering part number which gives you the best centring of your core insulation diameter and substitute **X** using table X, according to your conductor size and type. Add a 'K' for use up to 24 kV, add an 'M' for use up to 36 kV, add a 'P' for use up to 42 kV.

EXAMPLE:

The copper wire screened cable is 36 kV, 240 mm² stranded aluminium with a diameter over core insulation of 37.0 mm.

Order 3 x
3xM784TB/G-S-32-240BI2.

TABLE W

Ordering part number	Dia. over core insulation (mm)	
	min	max
3 x 784TB/G-S-15-X	16.0	22.0
3 x 784TB/G-S-19-X	20.0	26.5
3 x 784TB/G-S-22-X	23.5	31.0
3 x 784TB/G-S-27-X	28.5	37.5
3 x 784TB/G-S-32-X	34.0	42.5
3 x 784TB/G-S-37-X	39.0	48.5
3 x 784TB/G-S-43-X	45.5	56.0

TABLE X

Conductor sizes (mm ²)	Aluminium conductor		Aluminium and copper conductor	Copper conductor
	DIN hexagonal	Deep indent	Bolted	DIN hexagonal
35	35BI2	35BI1	16.95UN5 50.150UN5 95.240UN5 120.300UN5 185.400UN5 400.630UN5	35CU2
50	50BI2	50BI1		50CU2
70	70BI2	70BI1		70CU2
95	95BI2	95BI1		95CU2
120	120BI2	120BI1		120CU2
150	150BI2	150BI1		150CU2
185	185BI2	185BI1		185CU2
240	240BI2	240BI1		240CU2
300	300BI2	300BI1		300CU2
400	400BI2	400BI1		400CU2
500	500BI2	500BI1		500CU2
630	-	630BI1		630CU2

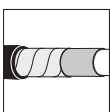

For use with copper tape screened cables.
Order: Kit MT.



For use in potentially explosive atmospheres (for 12 kV max.).
Order: -/ATEX.



For use with other cable types.
Please contact our representative.



For applications outdoors and in humid climate.
Order: +MWS.



Components can be ordered individually.

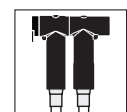

Multiple cable arrangement possible.
Please contact our representative.

APPLICATION

Separable coupling connector (bolted type) for dual cable arrangement. It has been designed to be used with 784TB separable tee connector.

TECHNICAL CHARACTERISTICS

- A thick conductive EPDM jacket provides a total safe to touch screen.
- Each separable connector is tested for AC withstand and partial discharge prior to leaving the factory.



DESIGN

1. Interface designed to fit 784TB connector.
2. Contact rod type 5/8".
3. Conductor connector (hexagonal crimping, deep indent crimping or bolted).
4. Conductive EPDM insert.
5. Conductive EPDM jacket.
6. Insulating EPDM layer moulded between the insert and the jacket.
7. Cable reducer.
8. Conductive EPDM cap.
9. Basic insulating plug 858BIPA (with VD point).
10. Earthing lead.

The screen break design enables cable outer sheath testing without removing or dismantling the connector.

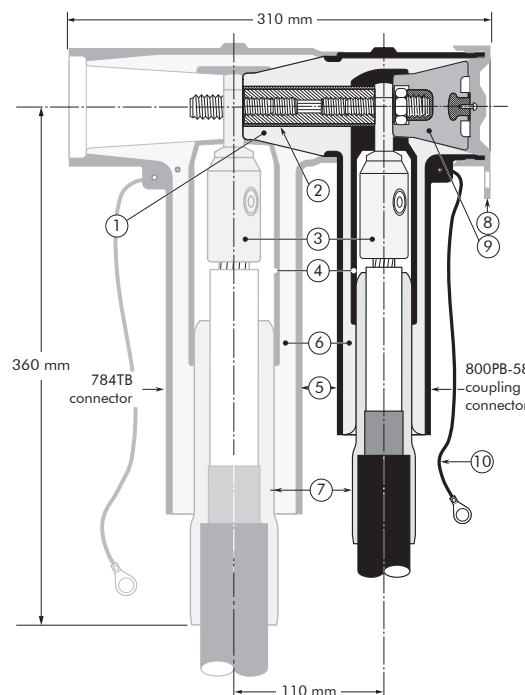

6/10 (12) kV
6.35/11 (12) kV
8.7/15 (17.5) kV
12/20 (24) kV
12.7/22 (24) kV
18/30 (36) kV
19/33 (36) kV
20.8/36 (42) kV

**Up to 42 kV
1250 A**

EUROMOLD®

SPECIFICATIONS AND STANDARDS

The 800PB-58 coupling connector meets the requirements of CENELEC HD 629.1.

Separable connector type	Voltage U_m (kV)	Current I_r (A)	Conductor sizes (mm ²)	
			min	max
800PB-58/G	12	1250	35	300
K800PB-58/G	24	1250	35	300
M800PB-58/G	36	1250	50	240
P800PB-58/G	42	1250	50	240

01/2022

KIT CONTENTS

The complete (K)(M)(P) 800PB-58/G coupling connector kit comprises 3 x the following components:

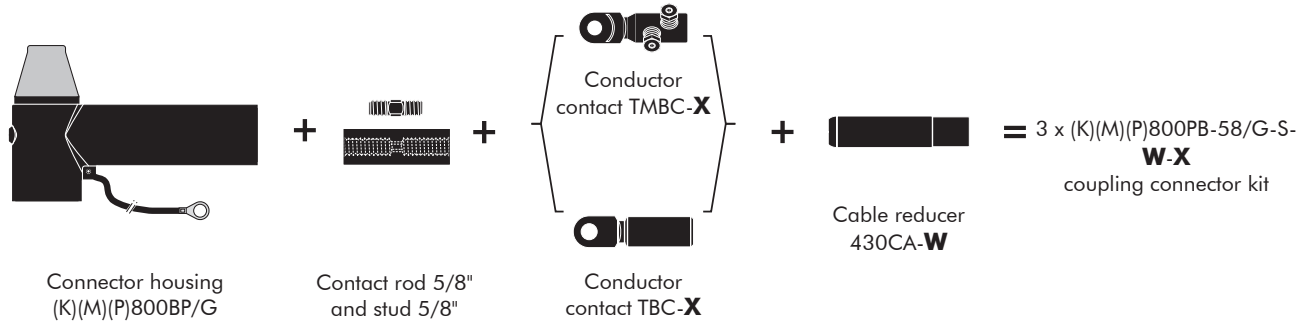

The kit also comprises silicone grease, field control mastic, installation rod, gloves, wipers, roll adhesive tape, installation instructions and crimp chart.

ORDERING INSTRUCTIONS

To order the coupling connector, select the ordering part number which gives you the best centring of your core insulation diameter and substitute **X** using table X, according to your conductor size and type.

Add a 'K' for use up to 24 kV, add an 'M' for use up to 36 kV, add a 'P' for use up to 42 kV.

EXAMPLE:

The cable is 24 kV, 150 mm² compact stranded copper with a diameter over core insulation of 27.5 mm.

Order 3 x K800PB-58/G-S-18-95.240UN5 coupling connector kit.

TABLE W

Ordering part number	Dia. over core insulation (mm)	
	min	max
3 x 800PB-58/G-S-11-X	12.0	17.5
3 x 800PB-58/G-S-16-X	17.0	23.5
3 x 800PB-58/G-S-18-X	19.0	32.6
3 x 800PB-58/G-S-27-X	28.5	37.5
3 x 800PB-58/G-S-30-X*	34.5	40.5

* will include an adapted installation instruction

TABLE X

Conductor sizes (mm ²)	Aluminium conductor		Aluminium and copper conductor	Copper conductor
	DIN hexagonal	Deep indent	Bolted	DIN hexagonal
35	35B12	35B11		35CU2
50	50B12	50B11		50CU2
70	70B12	70B11		70CU2
95	95B12	95B11		95CU2
120	120B12	120B11		120CU2
150	150B12	150B11		150CU2
185	185B12	185B11		185CU2
240	240B12	240B11		240CU2
300	300B12	-		300CU2

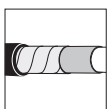

For use with copper tape screened cables.
Order: Kit MT.

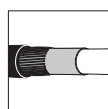

For use with copper wire screened cables.
No earthing device is necessary.



For use with other cable types.
Please contact our representative.



For outdoor applications.
Order: +MWS.



For use in potentially explosive atmospheres (for 12 kV max).
Add -/ATEX to part number.

APPLICATION

Separable coupling connector for dual cable arrangement. It has been designed to be used with 784TB separable tee connectors.

TECHNICAL CHARACTERISTICS

- A thick conductive EPDM jacket provides a total safe to touch screen.
- Each separable connector is tested for AC withstand and partial discharge prior to leaving the factory.



DESIGN

1. Interface designed to fit 784TB connector.
2. Contact rod type 5/8".
3. Conductor connector (hexagonal crimping, deep indent crimping or bolted).
4. Conductive EPDM insert.
5. Conductive EPDM jacket.
6. Insulating EPDM layer moulded between the insert and the jacket.
7. Cable reducer.
8. Conductive EPDM cap.
9. Basic insulating plug 858BIPA (with VD point).
10. Earthing lead.

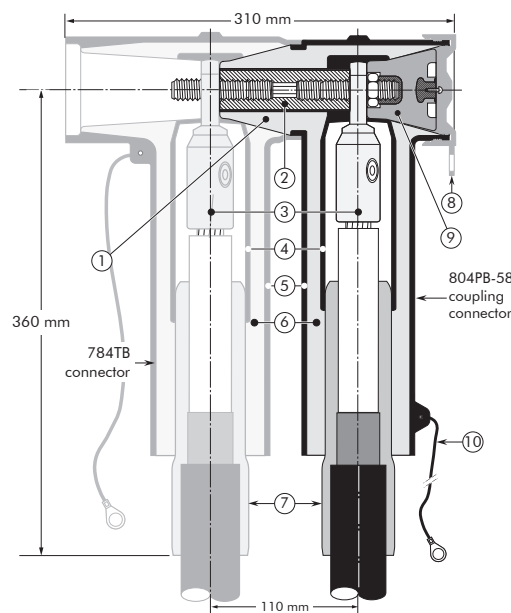

6/10 (12) kV
6.35/11 (12) kV
8.7/15 (17.5) kV
12/20 (24) kV
12.7/22 (24) kV
18/30 (36) kV
19/33 (36) kV
20.8/36 (42) kV

Up to 42 kV
1250 A

EUROMOLD®

The screen break design enables cable outer sheath testing without removing or dismantling the connector.

SPECIFICATIONS AND STANDARDS

The 804PB-58 coupling connector meets the requirements of CENELEC HD 629.1.

Separable connector type	Voltage U_m (kV)	Current I_r (A)	Conductor sizes (mm ²)	
			min	max
804PB-58/G	12	1250	50	630
K804PB-58/G	24	1250	35	630
M804PB-58/G	36	1250	35	630
P804PB-58/G	42	1250	35	630

01/2022

KIT CONTENTS

The complete (K)(M)(P)804PB-S-58/G coupling connector kit comprises 3 x the following components:

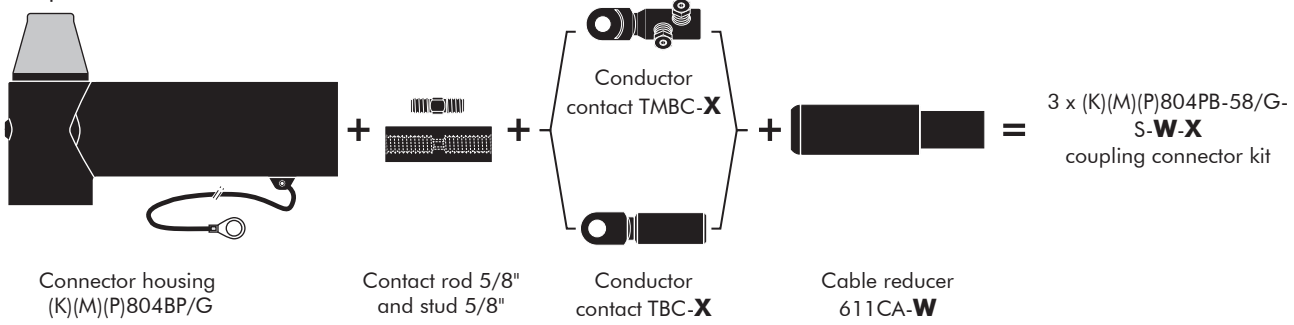

The kit also comprises silicone grease, field control mastic, gloves, wipers, roll adhesive tape, installation instructions and crimp chart.

ORDERING INSTRUCTIONS

To order the coupling connector, select the ordering part number which gives you the best centring of your core insulation diameter and substitute **X** using table X, according to your conductor size and type.

Add a 'K' for use up to 24 kV, add an 'M' for use up to 36 kV, add a 'P' for use up to 42 kV.

Example:

The copper wire screened cable is 36 kV, 240 mm² stranded aluminium with a diameter over core insulation of 37.0 mm. Order 3 x M804PB-58/G-S-32-240BI2 coupling connector kit.

TABLE W

Ordering part number	Dia. over core insulation (mm)	
	min	max
3 x 804PB-58/G-S-15-X	16.0	22.0
3 x 804PB-58/G-S-19-X	20.0	26.5
3 x 804PB-58/G-S-22-X	23.5	31.0
3 x 804PB-58/G-S-27-X	28.5	37.5
3 x 804PB-58/G-S-32-X	34.0	42.5
3 x 804PB-58/G-S-37-X	39.0	48.5
3 x 804PB-58/G-S-43-X	45.5	56.0

TABLE X

Conductor sizes (mm ²)	Aluminium conductor		Aluminium and copper conductor	Copper conductor
	DIN hexagonal	Deep indent	Bolted	DIN hexagonal
35	35BI2	35BI1		35CU2
50	50BI2	50BI1		50CU2
70	70BI2	70BI1		70CU2
95	95BI2	95BI1		95CU2
120	120BI2	120BI1		120CU2
150	150BI2	150BI1		150CU2
185	185BI2	185BI1		185CU2
240	240BI2	240BI1		240CU2
300	300BI2	300BI1		300CU2
400	400BI2	400BI1		400CU2
500	500BI2	500BI1		500CU2
630	-	630BI1		630CU2

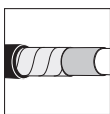

For use with copper tape screened cables. Order: Kit MT.

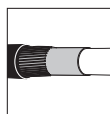

For use with copper wire screened cables. No earthing device is necessary.



For use with other cable types. Please contact our representative.



For applications outdoors and in humid climate. Order: +MWS.



Components can be ordered individually.



For use in potentially explosive atmospheres (for 12 kV max). Add -/ATEX to part number.

APPLICATION

Surge arrester designed to protect 12, 24, 36 and 42 kV class components, including transformers, equipment, cable and accessories from high voltage surges resulting from lightning or switching. It has been designed to be used with the 784TB separable tee connectors.

TECHNICAL CHARACTERISTICS

- This surge arrester is a metal oxide varistor surge arrester in an elbow configuration.
- Each arrester is tested for AC withstand, partial discharge and critical voltage prior to leaving the factory.



DESIGN

Surge arrester comprising:

1. Interface designed to fit the 784TB tee connector.
2. Conductive EPDM insert.
3. Conductive EPDM jacket.
4. Insulating EPDM layer moulded between the insert and the jacket.
5. Receptacle for contact rod.
6. Metal oxide valve elements.
7. Steel cap.
8. Earth connection.
9. Earth lead.

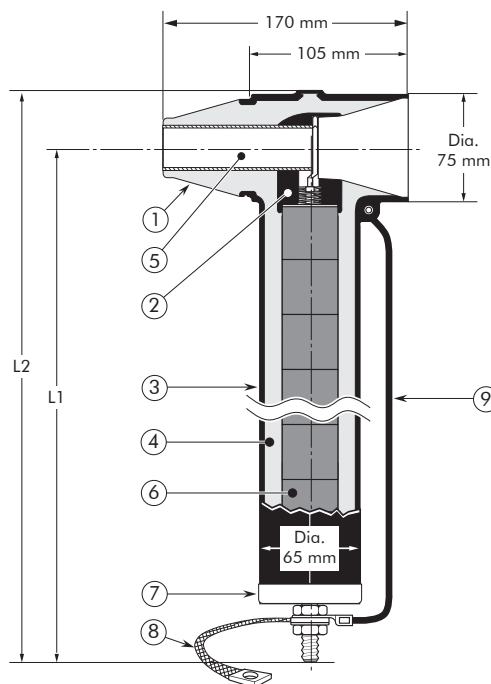

SPECIFICATIONS AND STANDARDS

The 800SA-58 surge arresters meet the test requirements of IEC 60099-4.

Surge arrester type	Nominal discharge current I_n (kA)	Rated voltage U_r (kV)	Max. continuous operating voltage U_c (kV)	Dimensions (mm)	
				L1	L2
800SA-58-10-6N	10	6	4.8	270	310
800SA-58-10-9N	10	9	7.2	270	310
800SA-58-10-12N	10	12	9.6	270	310
800SA-58-10-15N	10	15	12.0	270	310
800SA-58-10-18N	10	18	14.4	270	310
800SA-58-10-22N	10	22	17.6	270	310
800SA-58-10-24N	10	24	19.2	370	410
800SA-58-10-30N	10	30	24.0	370	410
800SA-58-10-33N	10	33	26.4	370	410
800SA-58-10-36N	10	36	28.8	370	410
800SA-58-10-45N	10	45	36.0	470	510
800SA-58-10-51N	10	51	40.8	470	510

01/2022

TYPICAL APPLICATION AND DIMENSIONS

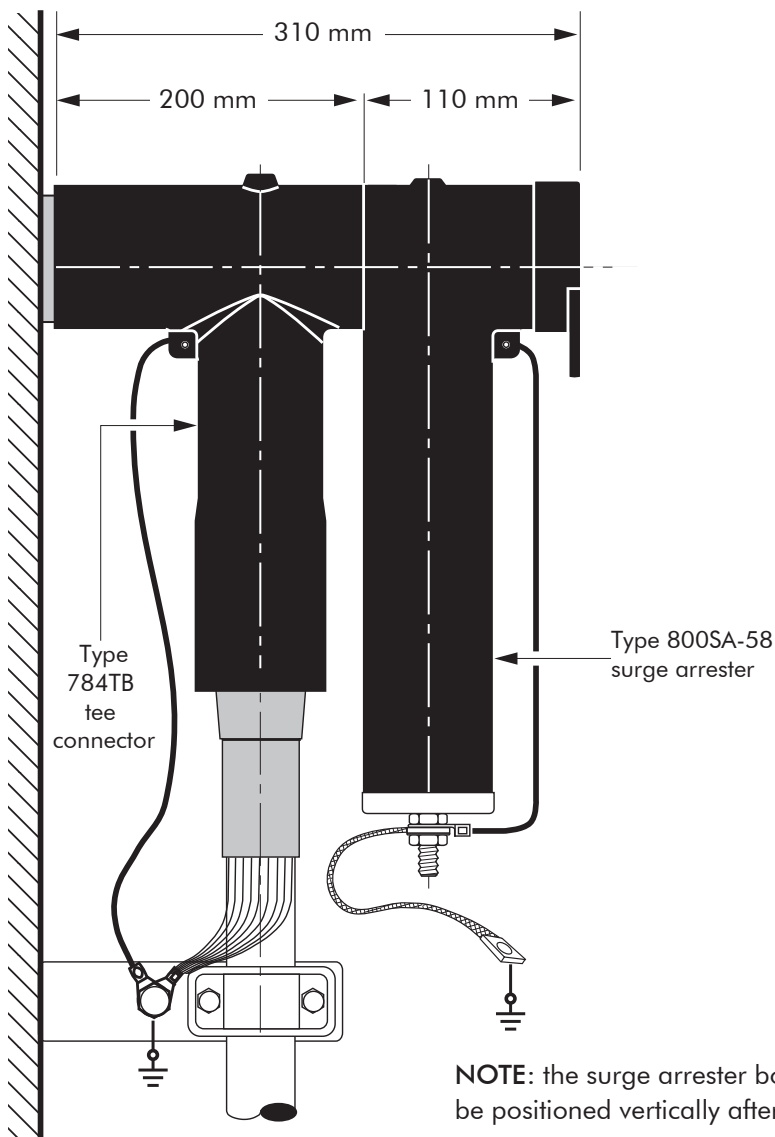

ORDERING INSTRUCTIONS

To order the surge arrester, specify the surge arrester type, as described on previous page.

EXAMPLE:

For a maximum continuous operating voltage (r.m.s.) of 24 kV and a nominal discharge current of 10 kA.

Order a 800SA-58-10-30N surge arrester.



For use in potentially explosive atmospheres (for 12 kV max).
Add -/ATEX to part number.

TECHNICAL DATA

Surge arrester type	Steep current residual voltage @ 10 kA [1/20 μs] (kV)	Lightning current residual voltage [8/20 μs] (kV)			Switching impulse residual voltage [36/90 μs] (kV)		High current impulse withstand (kA)
		@ 5 kA	@ 10 kA	@ 20 kA	@ 125 A	@ 500 A	
800SA-58-10-6N	20.4	16.8	18.3	20.5	12.9	13.7	100
800SA-58-10-9N	28.5	23.5	25.6	28.7	18.0	19.2	100
800SA-58-10-12N	38.0	31.4	34.2	38.3	24.1	25.7	100
800SA-58-10-15N	48.1	39.7	43.2	48.4	30.5	32.5	100
800SA-58-10-18N	58.1	48.0	52.2	58.5	36.8	39.2	100
800SA-58-10-22N	70.1	57.9	63.0	70.6	44.4	47.3	100
800SA-58-10-24N	77.0	63.6	69.2	77.6	48.8	52.0	100
800SA-58-10-30N	97.0	80.1	87.2	97.7	61.5	65.5	100
800SA-58-10-33N	103.4	85.4	93.0	104.2	65.6	69.9	100
800SA-58-10-36N	115.9	95.7	104.2	116.8	73.5	78.3	100
800SA-58-10-45N	144.1	119.0	129.5	145.1	91.3	97.3	100
800SA-58-10-51N	166.0	137.1	149.2	167.2	105.2	112.1	100

750S1, 775S1 & 775T1

INTERFACE E - 5/8" EQUIPMENT BUSHING

APPLICATION

For use in equipment insulated with oil fluid, typically for transformers, switchgear, capacitors...

TECHNICAL CHARACTERISTICS

Each bushing is tested for AC withstand and partial discharge prior to leaving the factory.

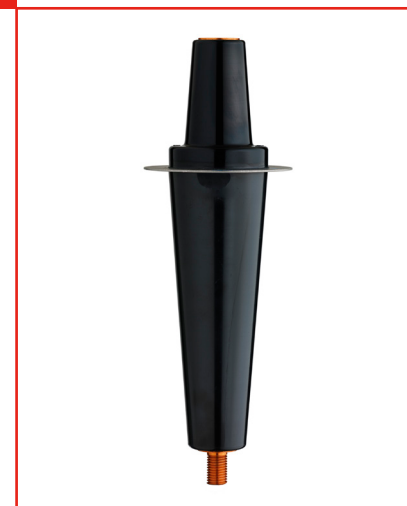

DESIGN

The equipment bushing is a moulded epoxy insulated part in accordance with ANSI/IEEE 386 std. (5/8" threading system).

SPECIFICATIONS AND STANDARDS

The bolted type equipment bushings 750S1, 775S1 and 775T1 meet the requirements of IEC 60137.

ORDERING INSTRUCTIONS

To order the equipment bushing, specify the type.

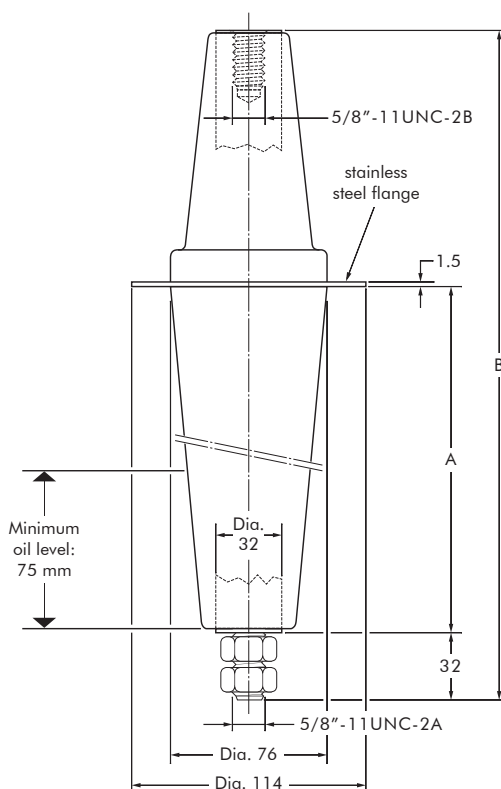

6/10 (12) kV
6.35/11 (12) kV
8.7/15 (17.5) kV
12/20 (24) kV
12.7/22 (24) kV
18/30 (36) kV

Up to 36 kV
800 A & 1250 A

EUROMOLD®

In mm.

Equipment bushing type	Voltage Ur (kV)	Current Ir (A)	Dimensions (mm)	
			A	B
750S1	36	800	75	235
775S1	36	1250	75	235
775T1	36	1250	221	378

01/2022

FIXINGS FOR EQUIPMENT BUSHINGS

750S1, 775S1 AND 775T1 BUSHINGS

BUSHING FIXING FLANGE

To order the bushing fixing flange, simply specify MK600-1.

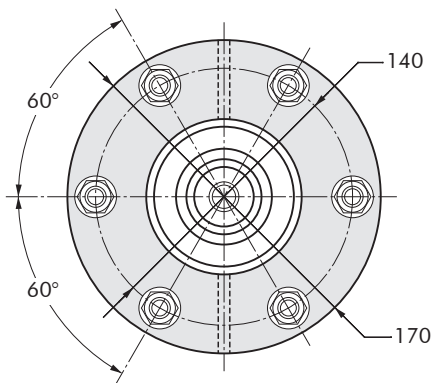
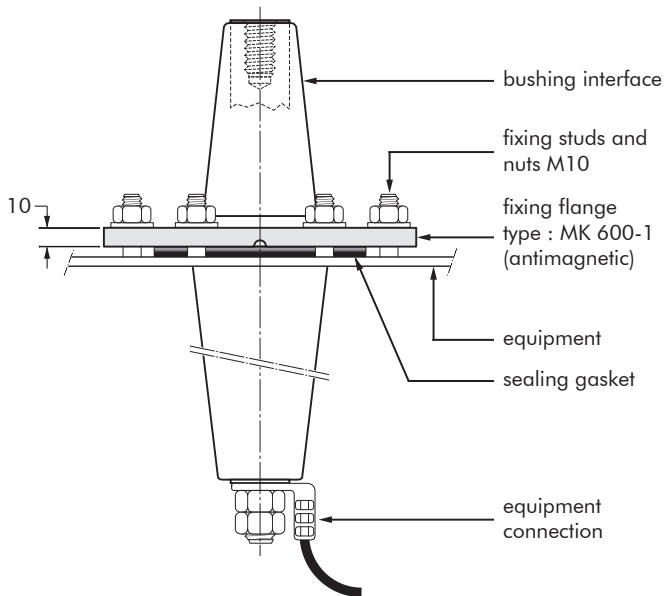

In mm.

ACCESSORIES

APPLICATION

For use with connectors and bushings with an INTERFACE E - 5/8" as described in IEEE std. 386.

TECHNICAL CHARACTERISTICS

All these products, except the earthing plug, are tested for AC withstand and partial discharge prior to leaving the factory.

6/10 (12) kV
6.35/11 (12) kV
8.7/15 (17.5) kV
12/20 (24) kV
12.7/22 (24) kV
18/30 (36) kV

Up to 36 kV

750CP & 775CP CONNECTING PLUG

For connecting two or more connectors with a type E - 5/8" interface together, thus creating a separable cable joint or a multiple cable connection to equipment.

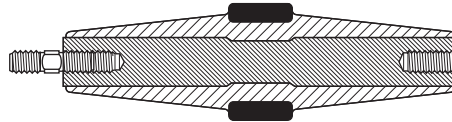

ORDERING INSTRUCTIONS

Order 750CP for 800 A or 775CP for 1250 A applications.

750BE & 775BE BUSHING EXTENDER

Provides an extension piece to allow cables to stand away from equipment. Is used in conjunction with the connecting plug (750CP or 775CP).

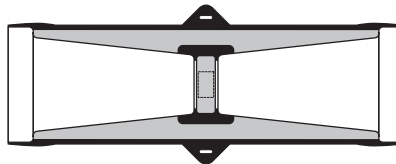

ORDERING INSTRUCTIONS

Order 750BE for 800 A or 775BE for 1250 A applications.

750SOP STAND-OFF PLUG

Is designed to support and 'dead-end' connectors with a type E - 5/8" interface when removed from equipment.

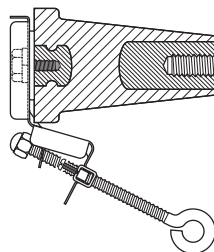

ORDERING INSTRUCTIONS

Order 750SOP for 800 A and 1250 A applications.

01/2022

750GP EARTHING PLUG

Is designed to support and earth connectors with a type E - 5/8" interface when removed from equipment.

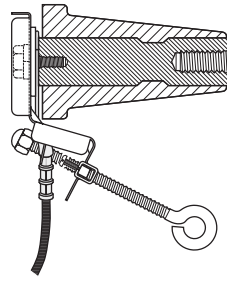

ORDERING INSTRUCTIONS

Order 750GP for 800 A and 1250 A applications.

KIT MT EARTHING KIT FOR COPPER TAPE SCREENED CABLES

Contains a finned copper braid (25 mm² - L = 500 mm), a finned copper wire for cleating and water sealing mastic.

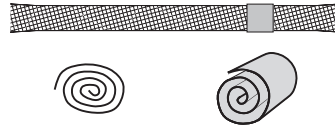

ORDERING INSTRUCTIONS

Order Kit MT for 800 A and 1250 A applications.

POSSIBLE ARRANGEMENTS

784TB

Single cable arrangement.
 Order 784TB for 12 kV,
 K784TB for 24 kV,
 M784TB for 36 kV or
 P784TB for 42 kV applications.

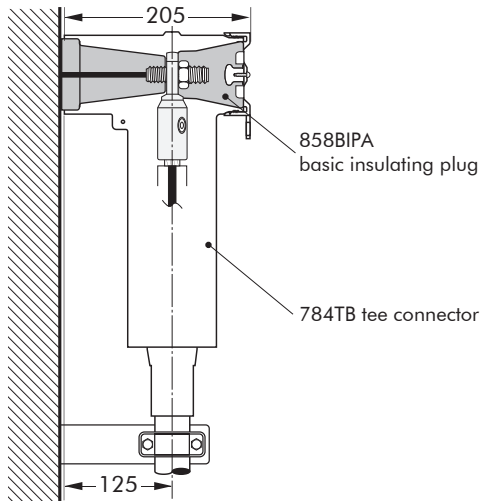

784TB+800PB-58

Dual cable arrangement.
 Order 784TB+800PB-58 for 12 kV,
 K784TB+K800PB-58 for 24 kV,
 M784TB+M800PB-58 for 36 kV
 or P784TB+P800PB-58 for 42 kV
 applications.

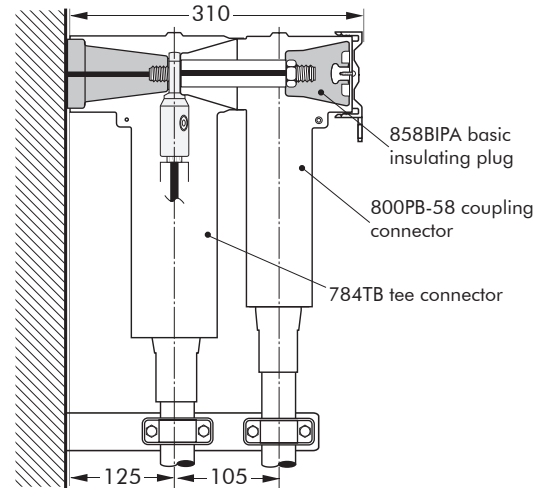

750BE+784TB

Connector standing away from
 equipment.
 Order 750BE+784TB for 12 kV,
 K750BE+K784TB for 24 kV or
 M750BE+M784TB for 36 kV
 applications.

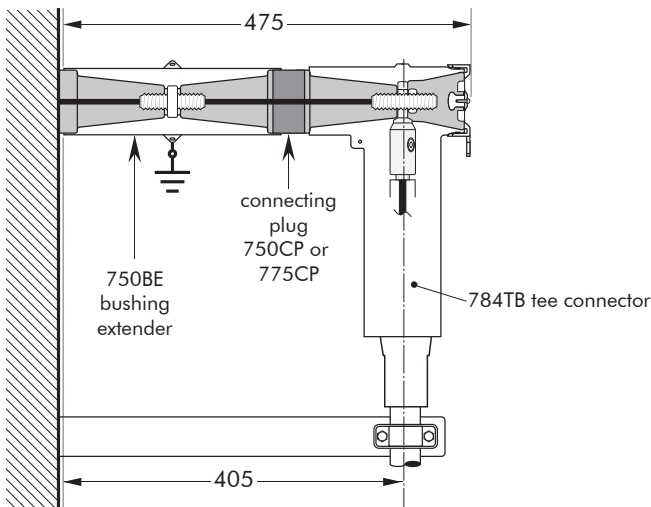

784TB+800SA-58

Dead-ending.
 Order 784TB+800SA-58 for 12 kV,
 K784TB+K800SA-58 for 24 kV,
 M784TB+M800SA-58 for 36 kV
 or P784TB+P800SA-58 for 42 kV
 applications.

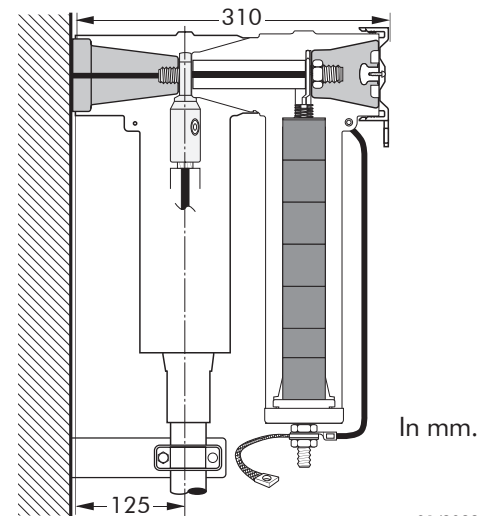

01/2022

CONNECTOR ON STAND-OFF PLUG

Order 750SOP for 12 kV,
K750SOP for 24 kV or M750SOP
for 36 kV applications.

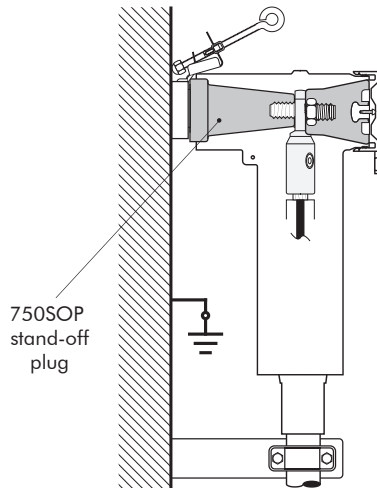

CONNECTOR ON EARTHING PLUG

Order 750GP for 12 kV, 24 kV or
36 kV applications.

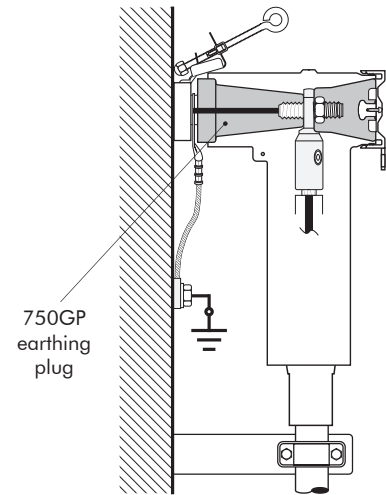

In mm.

NOTES



THORNE &
DERRICK
INTERNATIONAL

Thorne & Derrick
+44 (0) 191 410 4292
www.powerandcables.com

01/2022

ELECTRIFY THE FUTURE