

# STAKKAbox™ ULTIMA

## Access Chamber Section

1200mm x 1200mm



### Product Description

STAKKAbox™ ULTIMA offers a flexible access chamber system with no compromise on strength. Due to the design and the material used (GRP), ULTIMA should be used anywhere where sidewall loading is a concern, such as alongside highways or railway tracks.

### Product Details

Clear Opening:	1200mm x 1200mm	Weight:	20.4kg
External Dimensions:	1327mm x 1327mm	Product Code:	CPULRS-12001200
Stacking Depth:	150mm	Delivery Options:	Solid Ring
Actual Depth:	160mm		

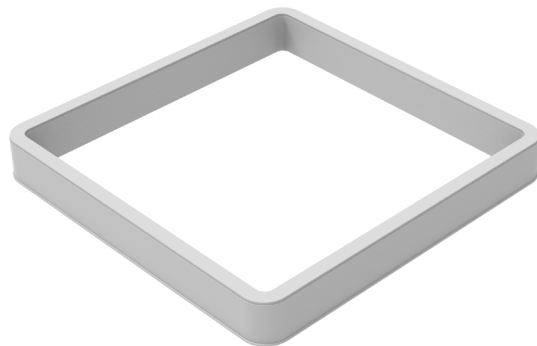

### Materials Properties

Material Profile	Glass Reinforced Polyester (GRP)	Grey
Tensile Strength	ISO 527-4	62 MPa
Flexural Strength	ISO 14125	142 MPa
Flexural Modulus	ISO 14125	9.6 GPa
Impact Strength	ISO 179	50 kJ/m <sup>2</sup>
Heat Distortion Temperature Range	ISO 75-2	>200 °C
Density	ISO 1183	1.7 g/cm <sup>3</sup>
Water Absorption	ISO 62	≤0.5%
Volume Resistivity	IEC 60093	1.00E12 ohm.cm
Fire Performance	UL 94	HB to V0
Limited Oxygen Index	ISO 4589-2	27%

### Installation

STAKKAbox™ ULTIMA has been tested to withstand vertical loads of EN124 E600. Please refer to the STAKKAbox™ Installation Guide for installation details.

### Key Features

- Fast and easy to install
- Sectional & twin wall design
- Smooth outer walls with lip to 'key' in



Scan for access to technical documents library

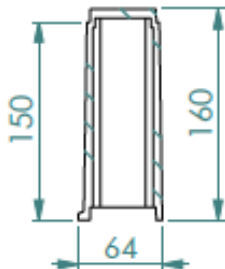

ULTIMA cross-section detail

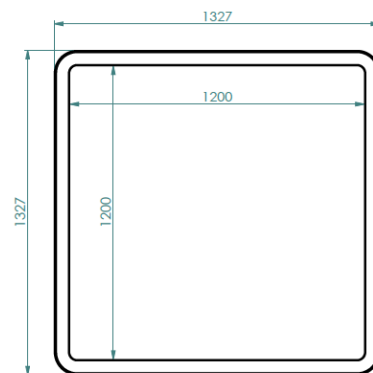

ULTIMA cross-section top view

CPUL-12001200 V.01 11/12/2018



**THORNE & DERRICK**  
INTERNATIONAL

**Thorne & Derrick**  
+44 (0) 191 410 4292  
www.powerandcables.com