

Company Directive

STANDARD TECHNIQUE: CA3V/4

Relating to Procedures for Making 33kV Cable Terminations

Policy Summary

This Standard Technique document contains all the approved 33kV cold applied/cold pour Terminations. It shall be implemented in conjunction with the appropriate General Requirements in ST: CA3C/3.

This ST has not been written as a training document. It is not intended to be exhaustive in content and you must refer to your supervisor if you require training or instruction.

You shall work safely and skilfully, utilising the training/instruction you have already received, relating to the contents of this document and its cross-references.

You must make sure that you understand your job instructions and that you have the necessary tools and equipment for the job.

All 185/300/400/630/800mm² OUTDOOR terminations shall be constructed in their final erected position.

Author: Paul Jewell

Implementation Date: October 2018

Approved by



Policy Manager

Date:

5 October 2018

All references to Western Power Distribution or WPD must be read as National Grid Electricity Distribution or NGED

NOTE: The current version of this document is stored in the NGED Corporate Information Database. Any other copy in electronic or printed format may be out of date. Copyright © 2022 National Grid Electricity Distribution

IMPLEMENTATION PLAN

Introduction

This updated Standard Technique defines all the standard 33kV terminations which are available for use on the 33kV underground cable used within WPD.

Main Changes

- Ensto O/D Terminations - dimension change

Impact of Changes

No major impact.

Implementation Actions

Existing 33kV Jointers will need to be made aware of the new document.

Implementation Timetable

Immediate.

REVISION HISTORY

Document Revision & Review Table		
Date	Comments	Author
October 2018	<ul style="list-style-type: none">• Dimension for Ensto coldshrink terminations changed to reflect manufacturers recommendations	Richard Summers
August 2017	<ul style="list-style-type: none">• 800mm² terminations added• Update and correction of minor dimensional errors	Richard Summers
July 2017	Update and correction of minor dimensional errors.	Richard Summers
March 2017	This is complete rewrite of the existing document.	Peter White

ST: CA3V/4 - PROCEDURES FOR MAKING 33kV CABLE TERMINATIONS

INTRODUCTION

This Standard Technique document contains all the approved 33kV Terminations, which shall be implemented in conjunction with the appropriate General Requirements, contained in ST: CA3C/3, including: -

1. General Cleanliness and Accident Prevention.
2. Joint Bay Preparation.
3. General Jointing Procedures – Dead Cables.

If the need arises to undertake a termination (i.e. non-standard) not covered within the Standard Technique the Policy Manager, Avonbank, is to be consulted.

Where 240mm² cable is to be found, then for material selection and installation data use 300mm² cable; but for the electrical purposes i.e. loadings, ratings etc. then the 240mm² cable shall be treated as 185mm².

Any reference to EPR equally applies to XLPE.

All crossing of cores will be undertaken outside of the cable box for Indoor Terminations and below the cable cleat of the crucifix for Outdoor Terminations.

Earth Fault Indicators (E.F.I's) are no longer fitted as standard, where there is a requirement then the appropriate procedure/drawing shall be consulted.

Cable boxes that have single core glands on entries (as opposed to three core cable glands) will require the base plate to be split and insulating material placed between the split (prevention of circulating currents), alternatively the base plate is to be of a non-ferrous metal i.e. in stainless steel, brass or aluminium.

NOTE:- All 185/300/400/630/800mm² OUTDOOR terminations shall be constructed in their final erected position.

CONTENTS

Description	Page
7.401 185/300/400/630/800mm ² CWS Single core – Indoor (EFI optional)	6
7.402 185/300/400/630/800mm ² CWS Single core – Outdoor	14
7.403 185/300mm ² + 400/630mm ² CWS Single core – Compound Filled	22
7.404 Not in use	
7.405 185mm ² CWS– (M)430 TB/G Separable. Connector	34
7.406 300/400/630/800mm ² CWS – (M)440 TB/G Separable Connector	49
7.407 630mm ² CWS – (M)440TB/G (P2) Separable Connectors (Back to back or piggy backed)	64
7.408 Installation of Euromold 400PB-10SA-36N outer cone surge diverters.	84
7.409 185/300/400mm ² CWS Single core Pfisterer Size 3 inner cone connector termination.	90
7.410 630/800mm ² CWS Single core Pfisterer Size 3XL inner cone connector termination.	102
7.411 Installation of Pfisterer size 3 inner cone surge diverters.	115

ST: CA3V/4 PROCEDURES FOR MAKING 33kV CABLE TERMINATIONS

JOINTING PROCEDURE 7.401

**185/300/400/630/800mm² SINGLE CORE CABLE 33kV INDOOR
TERMINATION**

**This procedure is to be read in conjunction with the appropriate
General Requirements ST: CA3C/3 Section 6
of the 33kV Jointing Manual**

JOINTING PROCEDURE 7.401

TERMINATION KIT MATERIALS

CABLE SIZE: - 185/300/400/630/800mm² Cu. Single Core

Termination Kit Materials – Jointing Procedure 7.401									
Cable size	Termination Module CIT1.4204L (set of 3)	Termination Module CIT1.4205L (set of 3)	Termination Module CIT1.4206L (set of 3)	Taped Bushing (set of 3)	Connector	Connector BET 120-12	Insulated Earth Stud	Tube Set	Compression gland zzzz
Copper 185mm ²	1	-		1	3 x VETB 21-12UTB	3	1	3	-
Copper 300mm ²	1	-		1	3 x VETB 28-12UTB -	3	1	3	-
Copper 400mm ²	-	1		1	3 x VETB 28-12UTB -	3	1	3	-
Copper 630mm ²	-	1		1	3 x VETC 33-12UTB	3	1	3	3
Copper 800mm ²			1	1	3 x VETC 44-120HUTB	3	1	3	3

ADDITIONAL ITEMS FOR EACH TERMINATION

PVC tape
 Scotch 70
 Scotch 13 tape
 Tinned copper wire 16 swg / 20swg
 De-solvit 1000
 Workhorse dry wipes
 Emery cloth
 5313 Water block tape
 Cable ties
 Sealing putty
 Aluminium oxide cloth 320/400 grit
 Copaslip

Note: - Individual material item numbers (E 5) are to be found in Section 4 of the 33kV Jointing Manual.

JOINTING PROCEDURE 7.401

Actions

General Requirements (ST: CA3C/3)

Refer to drawings JP3D 7.401.1

- | | | |
|-----|--|-----|
| 1. | Ensure cable box dimensions are suitable for terminations. | 46 |
| 2. | Identify and mark core phasing clear of termination position. | -- |
| 3. | Set and align cores into their termination positions, ensuring that any cross is undertaken well away from termination position. | -- |
| 4. | Clean each oversheath for a distance of 1.5m. | -- |
| 5. | Apply a temporary earth continuity bond clear of termination position. | 11 |
| 6. | Park a mastic lined heat shrink tube next to temporary earth continuity bond of each core. | -- |
| 7. | For Cu. conductors - park a compression gland over each cable or park a heat shrink tube over each core. | 54 |
| 8. | Park gland plate and gland over cores. | -- |
| 9. | Set and mark cores into their required positions. | 5/6 |
| 10. | Cut each core 300mm above its connection point. | -- |
| 11. | Place a connector on each bushing, measure and mark internal depth of barrel onto outside of connector. | -- |
| | This mark becomes the reference point for the procedure. | |
| 12. | Remove oversheaths and bedding tapes. | 17 |

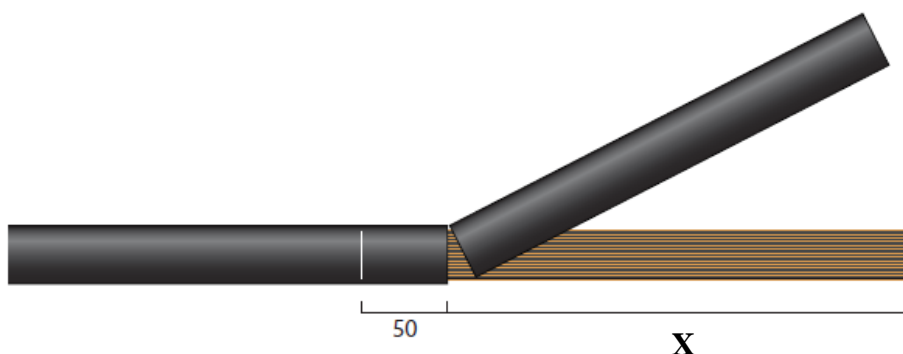

X = 380mm for 185-400mm²
X = 370mm for 630mm²/800mm²/1000mm²

- 13. Abrade oversheaths. 18
- 14. Apply a turn of SMG 400 grey mastic tape around oversheaths. --
- 15. Straighten copper screen wires and bend back over oversheath termination ensuring copper screen wires are spaced evenly and bedded into mastic tape applied in 15. --

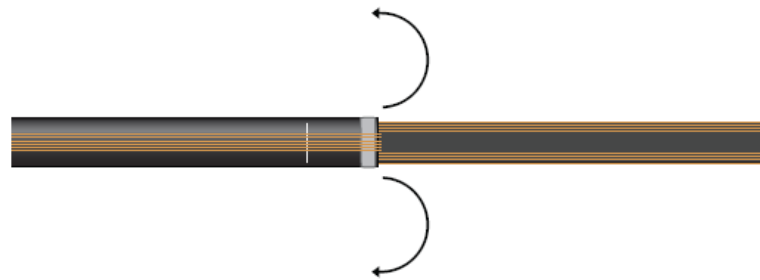

- 16. Apply three turns of 20 swg binder over copper screen wires at a point 480mm down from the reference point. --
- 17. Apply a second layer of SMG 400 mastic tape over copper screen wires and mastic tape applied in 15. --

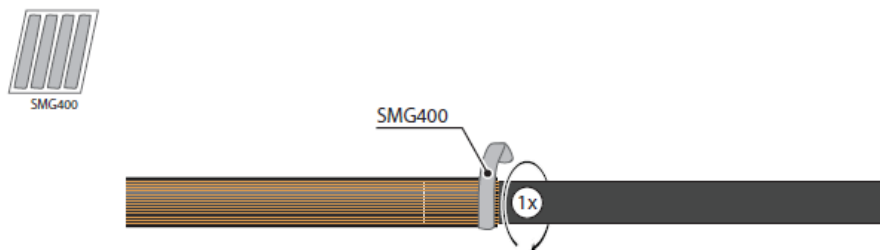

- 18. Cover mastic tape and down the screen wires to the binding wire applied in applied in 17 with two layers of PEE 225W tape and remove binder --

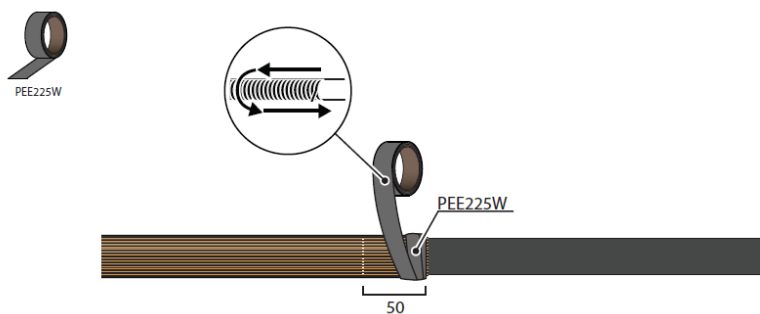

- 19. Remove semi-conducting screens ensuring insulation is free from all conductive material. 25

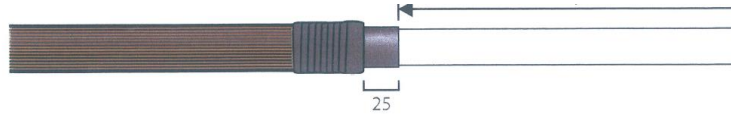

- 20. Remove core insulation (depth of barrel +5mm). Fit lug to the phase conductors; ensure connector palm is in correct position to bushings before shearing bolts. 28/33
- 21. Thoroughly clean the insulation using wipes provided --
- 22. Apply SMG 400 mastic in the gap between the barrel of the connector and the phase insulation ensure tape is level with phase insulation. 50

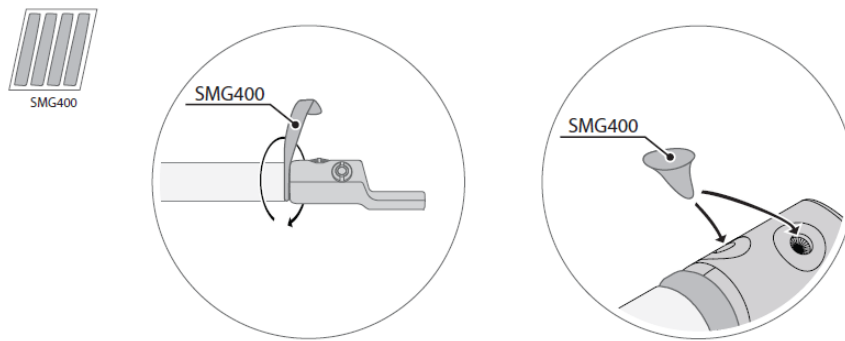

- 23. Apply two layers of PEE 225W tape over the barrel of the connector and SMG 400 tape applied in 24. Profile to reduce steps --

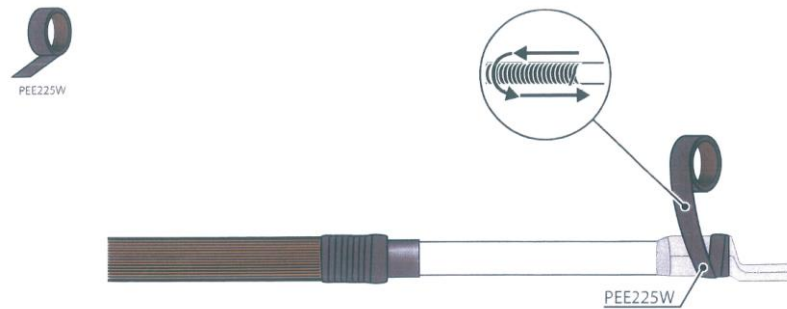

- 24. Apply silicon lubricant SSO 10 to PEE 225W cable insulation and 10mm on to the PEE 225W applied in 19. --

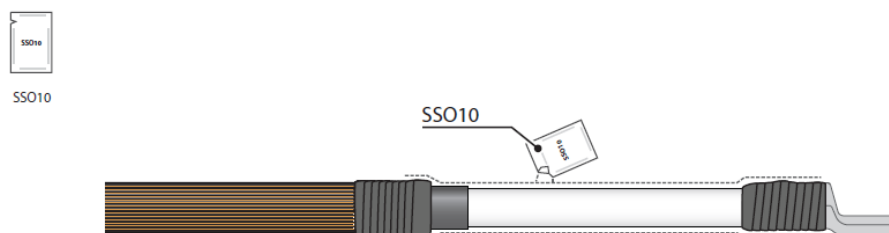

- 25. Apply termination body in line with the overshath termination. 50

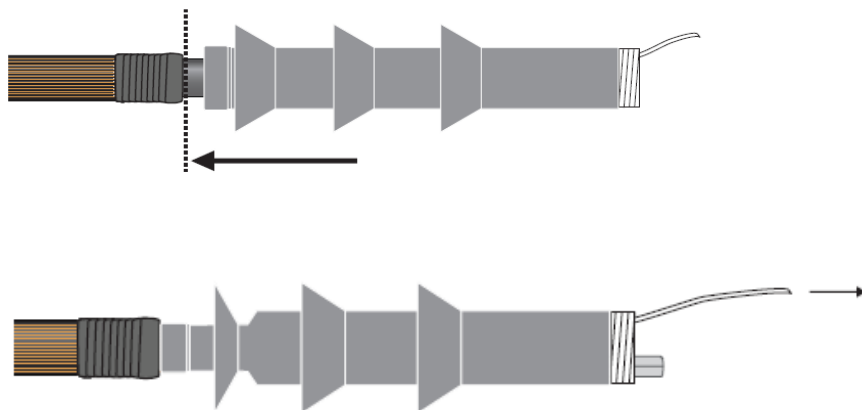

26. Remove binder and flip over the skirt of the termination onto the mastic

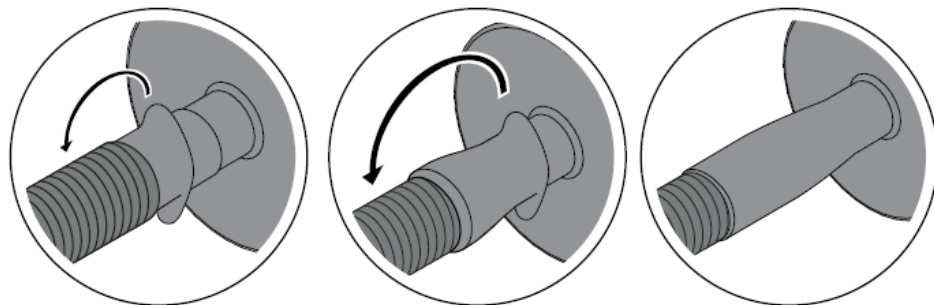

27. Apply four turns minimum of Scotch 88 tape around copper screen wires 10mm below termination body. On top of the Scotch 88 tape apply relevant phase colour PVC tape. --

Do not apply PVC tape to the termination body.

28. Form copper screen wires into a bunch --
29. Apply build up tape to centralise cable within gland. 54
30. Fit gland plate to cable box. --
31. Connect phase connectors to bushings. --
32. Install BET lug onto each copper screen wire bunch and connect to earth stud. 33
33. Position heat shrink breakout over gland and shrink into position. 45

Note: - If an EFI is to be fitted move to action 36.

34. Connect switchgear/transformer earth to gland plate earth stud. --
35. Remove temporary earth continuity bond applied in 6 and reseal oversheaths. 11/45

36. Replace cable box cover ensuring all external bolt threads are treated with "Copaslip" paste and security bolts are in place. --



All dimensions in mm

Note :- 185mm² Conductor X = 65
 300/400/630mm² Conductor X = 70

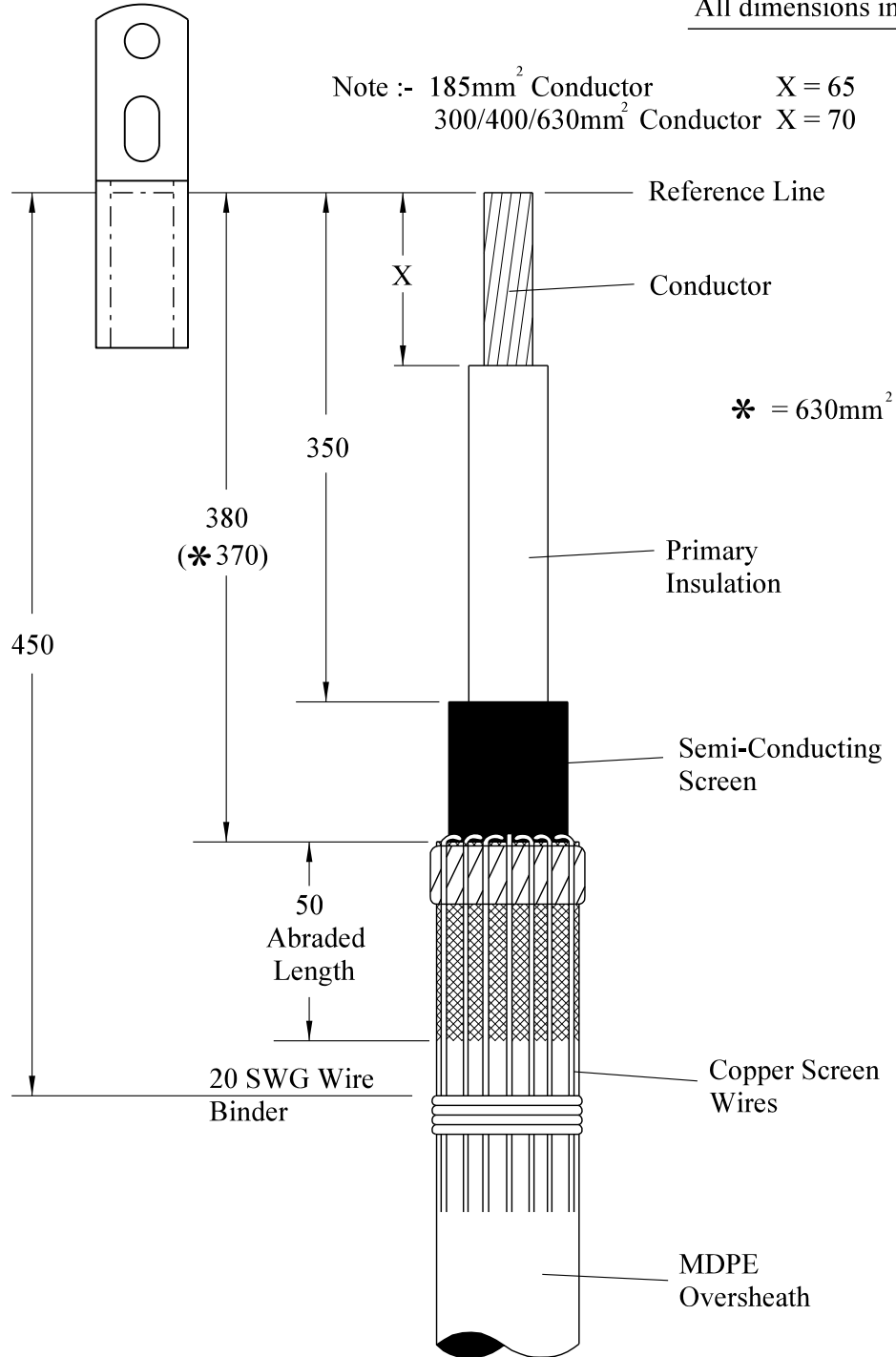

Rev No	Drawn	Chk'd	App'd	Date	Revision	
ORIGINAL ISSUE	DATE	WESTERN POWER DISTRIBUTION Design Department. Avonbank, Feeder Road, Bristol BS2 0TB Tel: 0117 933 2000 Fax: 0117 933 2001.				
Drawn	RJB	10/16	Title 185/300/400/630mm ² EPR SINGLE CORE 33kV INDOOR TERMINATION STRIPPING DIMENSIONS			
Checked					JP3D 7.401.1	
Approved						
SCALE	N.T.S.					

ALL RIGHTS ARE RESERVED TO WPD (South West) plc. NO PART OF THIS DRAWING MAY BE REPRODUCED OR TRANSMITTED IN ANY FORM OR BY ANY MEANS, INCLUDING PHOTOCOPYING AND RECORDING, OR STORED IN A RETRIEVAL SYSTEM OF ANY NATURE, WITHOUT PERMISSION.

ST: CA3V/4 PROCEDURES FOR MAKING 33kV CABLE TERMINATIONS

JOINTING PROCEDURE 7.402

**185/300/400/630/800mm² Cu SINGLE CORE CABLE 33kV OUTDOOR
TERMINATION**

(This termination shall be constructed at its final erected position only.)

**All overhead items for the crucifix etc. can be found in ST: OH4H/5 page 47
for the H pole and page 48 for the single pole arrangement.**

**This procedure is to be read in conjunction with the appropriate
General Requirements ST: CA3C/3 Section 6
of the 33kV Jointing Manual**

JOINTING PROCEDURE 7.402

TERMINATION KIT MATERIALS

CABLE SIZE: - 185/300/400/630/800mm² Cu Single core.

Termination Kit Materials – Jointing Procedure 7.402											
Cable size	Termination Module COT14204 (set of 3)	Surge Diverter (set of 3)	Phase Connector	Connector BET 120-12	Crucifix	Surge Arrester Adaptor Plate	Copper earth bar kit	Cable cleat AR3-A35-TB	Cable cleat AR3-A36-TB	Cable cleat AR4-A37-TB	Cable cleat AR4-A38-TB
185mm ²	1 COT14204 (set of 3)	1	3x VTPB 21-12 OHUTB	1	1	3	1	1	-	-	-
300mm ²	1 COT14204 (set of 3)	1	3x VETC 28-12 OHUTB	1	1	3	1	-	1	-	-
400mm ²	1 COT1.4205L (set of 3)	1	3x VETC 28-12 OHUTB	1	1	3	1	-	-	1	-
630mm ²	1 COT1.4205L (set of 3)	1	3x VETC33-12 OHUTB	1	1	3	1	-	-	-	1
800mm ²	1 COT1.4206 (set of 3)		3x VETC44-120HUTB	1	1	3	1				1

ADDITIONAL ITEMS FOR EACH TERMINATION

PVC tape / Scotch 70 / Scotch 13 tape
 Tinned copper wire 16 / 20swg
 De-solvit 1000 FD
 De-solvit 1000
 Workhorse dry wipes
 Emery cloth
 5313 Water block tape
 Sealing putty
 Aluminium oxide cloth 320 /400grit
 Heavy-duty cable ties
 Copaslip

Note: - Individual material item numbers (E 5) are to be found in Section 4 of the 33kV Jointing Manual.

JOINTING PROCEDURE 7.402

Actions	General Requirements (ST: CA3C/3)
---------	--------------------------------------

Refer to Drawing **JP3D 7.402.6** whilst undertaking this Jointing Procedure.

- | | |
|---|-----|
| 1. Obtain required termination height and line phasing. | -- |
| 2. Assemble crucifix and associated equipment and fit to pole at the final position. | 49 |
| 3. Run cables up the pole/H pole arrangement and cleat into position. | -- |
| 4. Set and cut cable to length. | 5/6 |
| 5. Unravel and straighten individual cores. | -- |
| 6. Identify and mark core phasing clear of termination position. | -- |
| 7. Fit cable to crucifix, ensure any crossing is undertaken below crucifix cable cleat. | 22 |
| 8. Set and align cores into their termination positions. | 22 |
| 9. Place a connector on each surge arrester adaptor plate, measure and mark internal depth of barrel onto outside of connector. | -- |
| This mark becomes the reference point for the procedure. | |
| 10. Clean each oversheath for a distance of 1.5m. | -- |
| 11. Remove oversheaths and bedding tapes. | 17 |

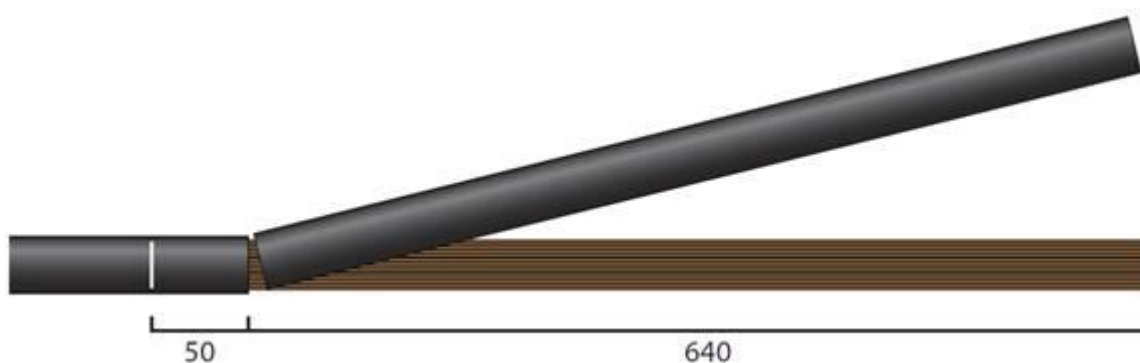

- | | |
|---------------------------------|----|
| 12. Abrade oversheath for 50mm. | 18 |
|---------------------------------|----|

13. Apply a turn of SMG 400 mastic tape around overshooth. --

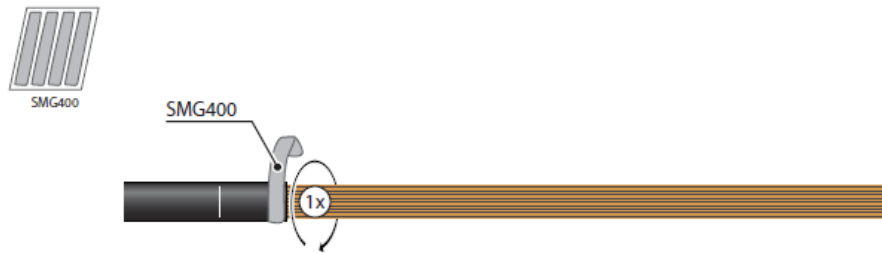

14. Straighten copper screen wires and bend back over overshooth termination ensuring copper screen wires are spaced evenly and bedded into mastic tape. --

15. Apply three turns of 20 swg binder over copper screen wires at a point 665mm down from the reference point.

16. Apply a second layer of SMG 400 mastic tape over copper screen wires. --

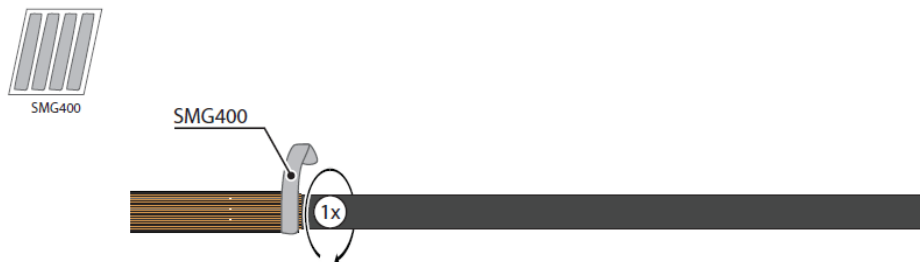

17. Cover mastic tape seal with two layers of PEE225W tape overlapping onto copper screen wires by 5mm. --

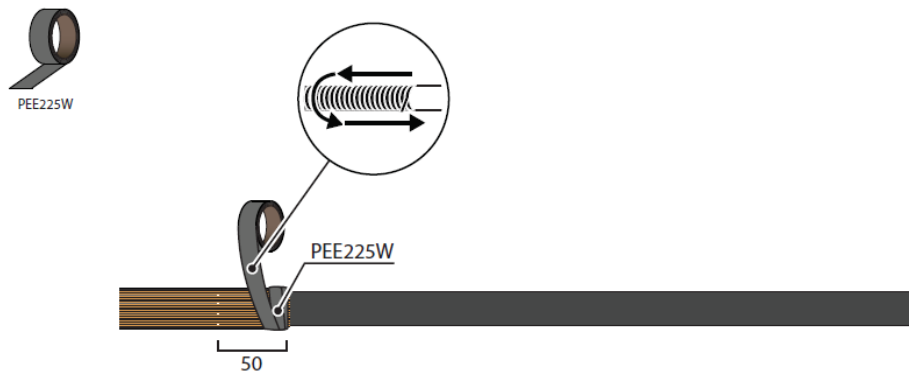

- 18. Offer cores to reference point marked on connectors, mark and cut cores. 27
- 19. Remove semi-conducting screens ensuring insulation is free from all conductive material. 25

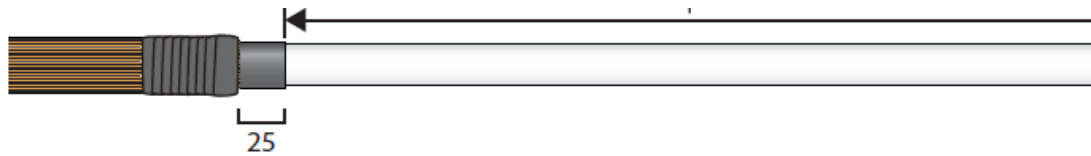

- 20. Remove core insulation (depth of barrel +5mm). Fit the lug and connect to phase conductors; ensure connector palm is in correct position to surge diverters adaptor plate before shearing bolts. 27/33
- 21. Thoroughly clean the insulation with DeSolvit 1000FD. 40
- 22. Apply SMG 400 mastic in the gap between the barrel of the connector and the phase insulation ensure tape is level with phase insulation. 50

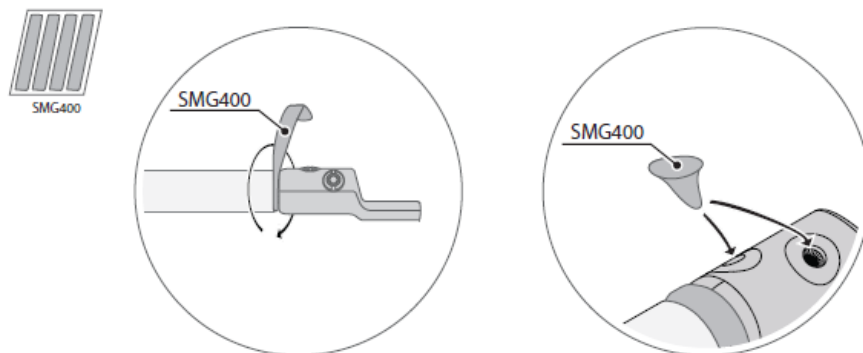

- 23. Apply two layers of PEE 225W tape over the barrel of the connector and SMG 400 tape applied in 21. --

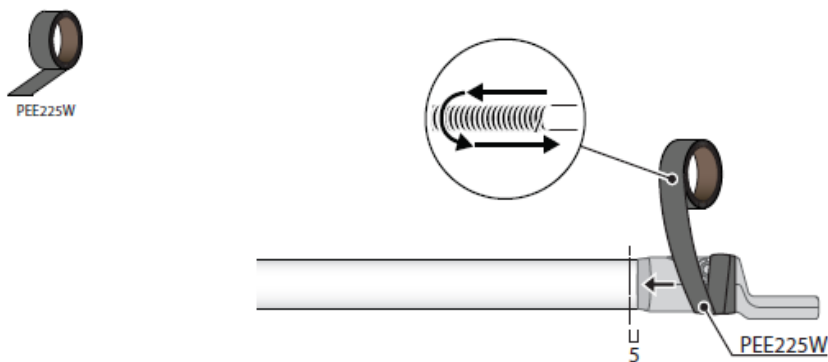

25. Apply silicon grease to the insulation for the length of the first termination body and 10mm onto the PEE225W applied in 19. --

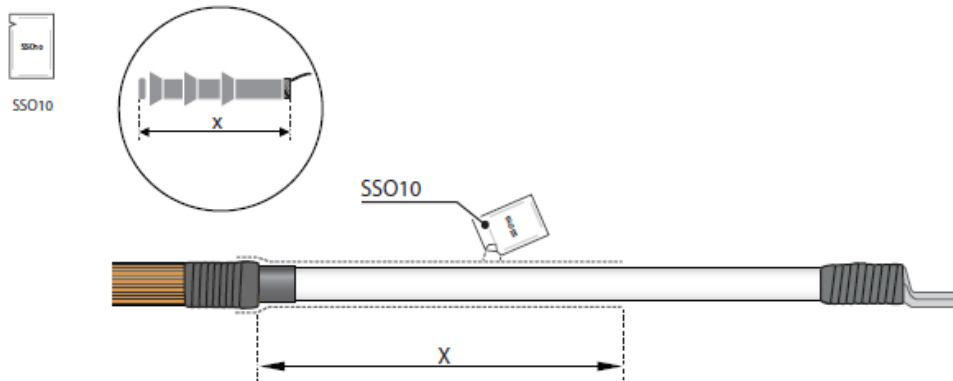

26. Apply first termination body CTSBGEL27-70L, remove the binder and flip over the skirt. 50

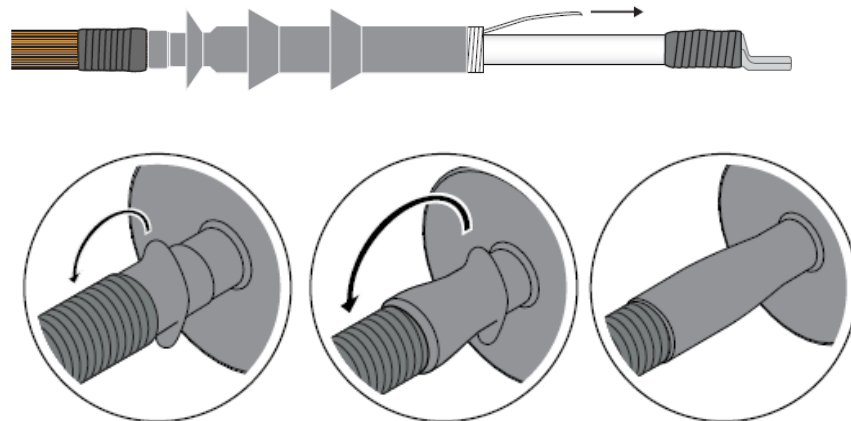

27. At the end of the first termination body CTSBGEL27-70L apply one layer of SMG 400 tape for a distance of 10mm. --

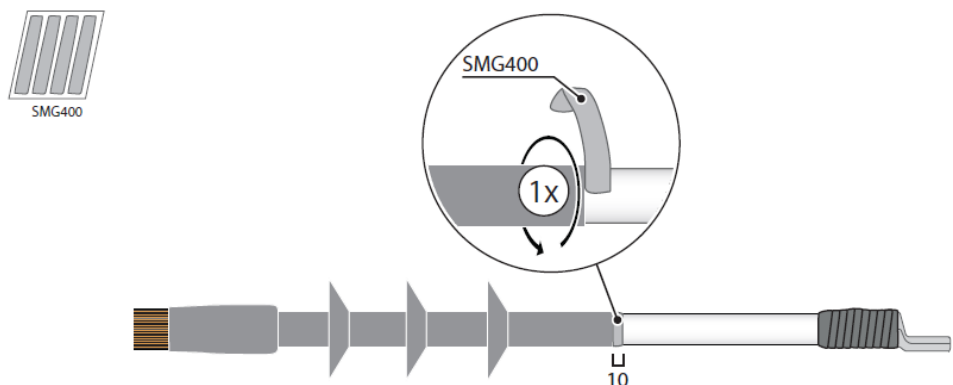

28. For a distance of 20mm and straddling the SMG 400 tape applied in 27 apply two layers of 50% overlap PEE225W tape under slight tension. --

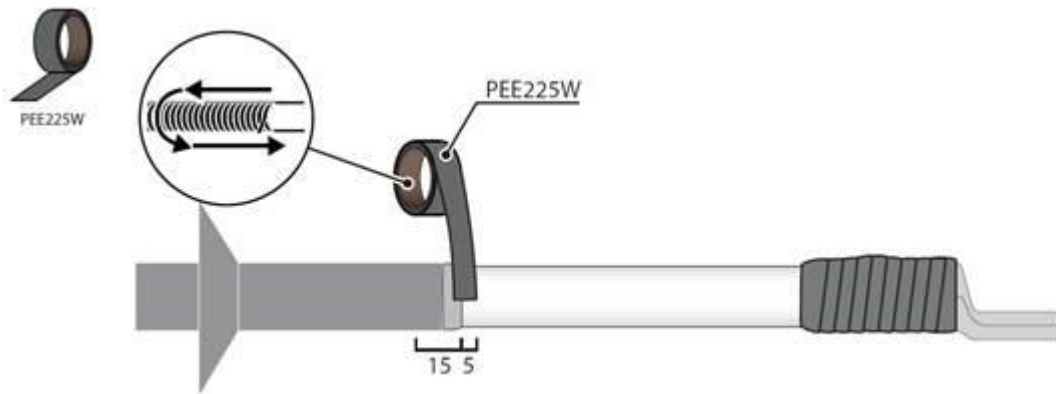

29. Apply silicon lubricant SSO 10 up to the first shed of the first termination body over the insulation and the PEE 225W tape applied to the cable lug. --

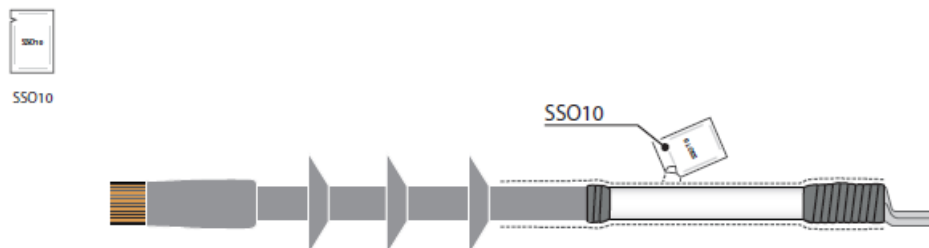

30. Apply second termination body CTSCGE27-70L leaving a 30mm gap between the first shed and the end of the body. 50

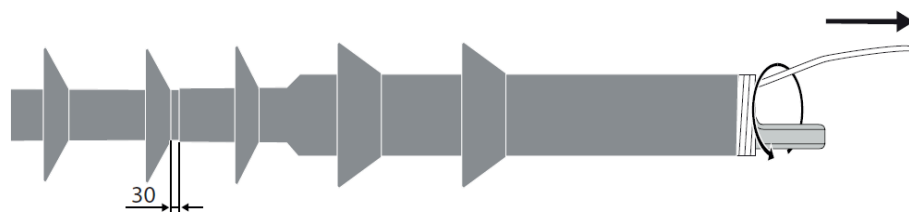

31. Apply four turns minimum of Scotch 88 tape around copper screen wires 10mm below termination body. On top of the Scotch 88 tape apply relevant phase colour PVC tape. --

Do not apply PVC tape to the termination body.

32. Form copper screen wires into a bunch and remove 20 swg binder applied in 14. --

33. Form copper screen wire bunches into one conductor terminating into a earth connector, and connect to crucifix earth stud. 33

All dimensions in mm

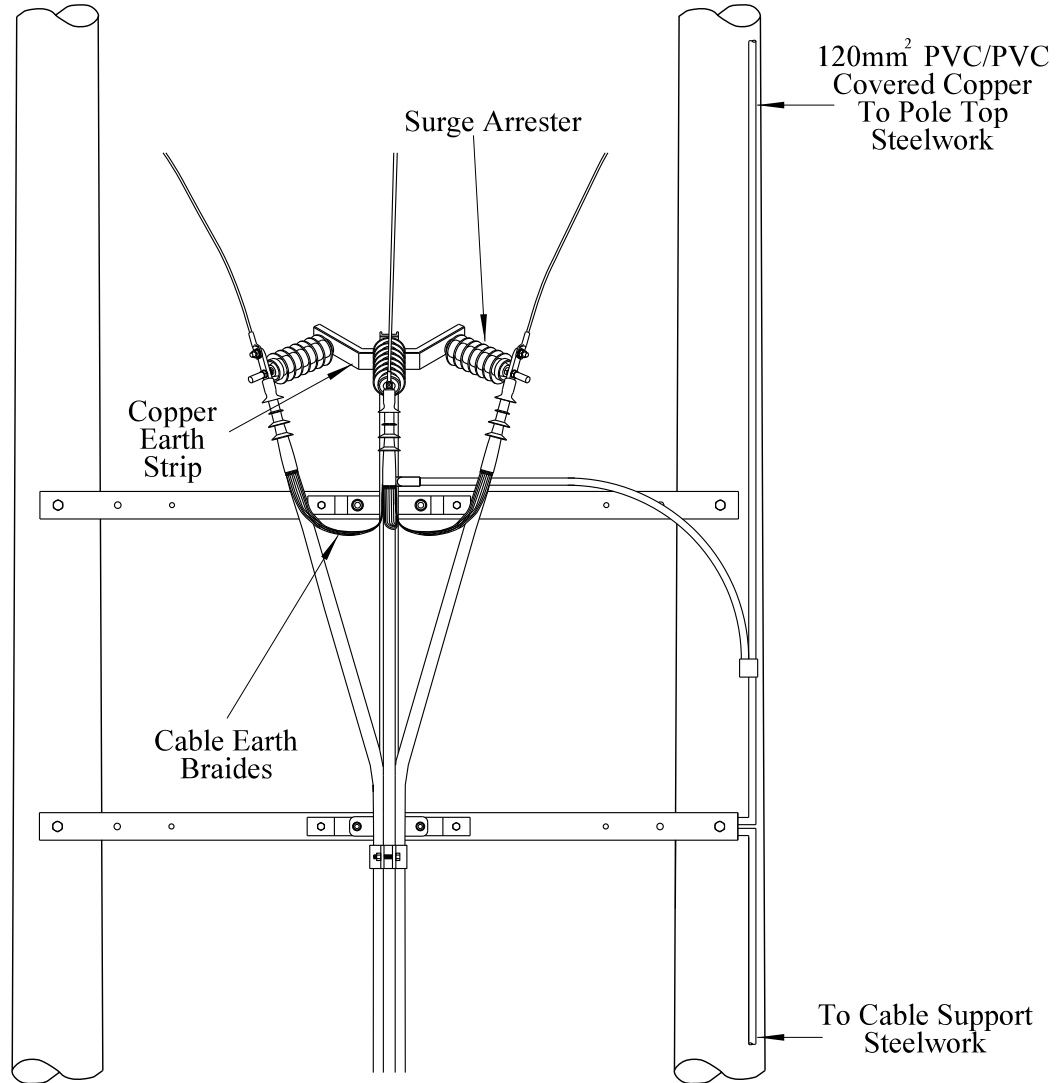

Rev No	Drawn	Chk'd	App'd	Date	Revision		
ORIGINAL ISSUE					WESTERN POWER DISTRIBUTION Design Department. Avonbank, Feeder Road, Bristol BS2 0TB Tel: 0117 933 2000 Fax: 0117 933 2001.		
Drawn	RJB	10/16		WESTERN POWER DISTRIBUTION			
Checked							Drg. No.
Approved				JP3D 7.402.6			
SCALE	N.T.S.		Title 185/300/400/630mm ² Cu EPR SINGLE CORE 33kV OUTDOOR TERMINATION STRIPPING DIMENSIONS				

ALL RIGHTS ARE RESERVED TO WPD (South West) plc. NO PART OF THIS DRAWING MAY BE REPRODUCED OR TRANSMITTED IN ANY FORM OR BY ANY MEANS, INCLUDING PHOTOCOPYING AND RECORDING, OR STORED IN A RETRIEVAL SYSTEM OF ANY NATURE, WITHOUT PERMISSION.

ST: CA3V/4 PROCEDURES FOR MAKING 33kV CABLE TERMINATIONS

JOINTING PROCEDURE 7.403

**185/300mm² and 400/630mm² SINGLE CORE CABLE 33kV COMPOUND
FILLED TERMINATION**

(This Jointing Procedure also makes provision for Island Layer Assemblies)

**This procedure is to be read in conjunction with the appropriate
General Requirements ST: CA3C/3 Section 6
of the 33kV Jointing Manual**

JOINTING PROCEDURE 7.403

TERMINATION KIT MATERIALS

CABLE SIZE: - 185/300mm² Single core

Item	Quantity
185mm²	
Connector VETB 21-12/16UTB	3
Connector BET-120	2
3M QT3 94-EP630-WPD (set of 3)	1
Sealing Sleeves WCSM 120/40 x 350	3
Resin Module RM-B	1
Silicon Compound 4.7 litres	Quantity to suit Cable box
Earth Stud	1
Y Gland - non-ferrous	3

300mm²

Connector VETC28-12/16UTB	3
Connector BET-120	2
3M QT3 94-EP630-WPD (set of 3)	1
Sealing Sleeves WCSM 120/40 x 350	3
Resin Module RM-B	1
Silicon Compound 47 litres	Quantity to suit Cable box
Earth Stud	1
Y gland – non-ferrous	3

CABLE SIZE: - 400/630mm² Single core

Item	Quantity
400mm²	
Connector VETC28-12/16UTB	3
Connector BET-120	2
Termination Module 3M QT3 94-EP640 (set of 3)	1
Sealing Sleeves WCSM 120/40 x 350	3
Resin Module RM-B	1
Silicon Compound 4.7 litres	Quantity to suit Cable box
Earth Stud	1
Y Gland - non-ferrous	3

630mm²

Connector VETC33-12/16UTB	3
Connector BET-120	2
Termination Module 3M QT3 94-EP640 (set of 3)	1
Sealing Sleeves WCSM 120/40 x 350	3
Resin Module RM-B	1

Silicon Compound 47 litres	Quantity to suit Cable box
Earth Stud	1
Y gland – non-ferrous	3

Note: - Two part resin packs not used within Resin Module-B must be mixed before disposal.

ADDITIONAL ITEMS FOR EACH TERMINATION

PVC tape
 Scotch 70
 Scotch 13 tape
 Tinned copper wire 16 swg
 Tinned copper wire 20 swg
 De-solvit 1000 FD
 De-solvit 1000
 Workhorse dry wipes
 Emery cloth
 5313 Water block tape
 Cable ties
 Sealing putty
 Aluminium oxide cloth 320 grit
 Aluminium oxide cloth 400 grit
 Copaslip
 Siligasket

Note: - Individual material item numbers (E 5) are to be found in Section 4 of the 33kV Jointing Manual.

JOINTING PROCEDURE 7.403

CABLE BOX PREPARATION

Before commencing this jointing procedure the following points must be observed and followed.

Where possible the existing cable box should be removed and replaced with new, a new box to fit existing transformers/switchgear may be obtained from Webster Wilkinson Ltd, the details are as follows: -

1. Establish the make and type of transformer/switchgear.
2. Contact Webster Wilkinson Ltd in Telford on 01952 585701 ask for Mr Kevin Allison Sales Manager. Give details of the make and type of switchgear/transformer cable box required. When ordering the new box ask for single cable entry and a stainless steel gland plate, giving the diameter of hole size required to fit the appropriate gland and insulated earth stud. The new cable box must come complete with through bushings.
3. When installing the new gaskets siligasket is to be applied to both surfaces of the new gasket prior to the gasket being fitted, this will provide a leak proof seal.

Where it is not possible to change the complete cable box, then the existing cable box must be prepared as follows: -

1. Firstly the cable box needs to be 'burnt out' using infra-red lamps to heat up the G 38 and get it flowing, this needs to be captured to prevent an environmental issue, the G 38 then needs to be disposed as hazardous waste. The cable box needs to be cleared of the majority of the G38 looking for high 95-97% of G 38 removal, using De-Solvit 1000FD will hasten the cleaning.
2. Ideally the plumbs should be removed from the Y glands so that they can be reused for the cable this will mean they don't have to find glands that fit, also the alignment for the cables will be right for the connection points. The island layer of the insulated gland can be removed so the gland becomes 'solid', *unless frame leakage protection is fitted to the switchgear.*
3. The gland plate needs to be checked as being non-ferrous metal. If it is made from ferrous metal it shall be replaced with a non-ferrous metal of similar configuration and dimensions.

4. Once the existing cables have been removed then the new flexible connections are to be provided as the original flexibles are designed for two ½” BSF HTS fine screws and nyloc nuts are fitted to each flexible. These shall be changed to one 12mm stainless steel nut and bolt to marry up with the palm of the respective end termination or lug.
5. With the new flexibles in place complete with the lug fitted in place the dimension from the bottom of the lug’s barrel to the gland plate shall be checked there should be 551mm. Place a connector on each flexible, measure and mark internal depth of barrel onto outside of connector.

This mark becomes the reference point for the procedure.

6. If phase barriers are fitted which drop down to the gland plate then three insulated brass studs shall be fitted to the gland plate E 5 No 41409.
7. All cork gaskets to be replaced with new cork gaskets when these gaskets are re-applied then Sili-gasket E 5 No 42350 shall be applied on both surfaces of the cork gasket to prevent the Lovisil from leaking out.

JOINTING PROCEDURE 7.403

Actions	General Requirements (ST: CA3C/3)
Refer to Drawing JP3D 7.403.1, 7.404.1, 7.403.2 and 7.403.3 whilst undertaking this Jointing Procedure.	
1. Ensure cable box dimensions are suitable for terminations.	--
2. Remove existing and fit new cable box, alternatively prepare existing cable box.	--
3. Unravel and straighten individual cores.	--
4. Identify and mark core phasing clear of termination position.	--
5. Set and align cores into their termination positions, ensuring that any cross is undertaken well away from termination position.	5/6
6. Clean each oversheath for a distance of 1.5m.	--
7. Apply a temporary earth continuity bond clear of termination position.	11
8. Park a mastic lined heat shrink tube next to temporary earth continuity bond of each core.	--
9. Park a heat shrink sealing sleeve over cores.	--
10. Park gland plate and gland over cores.	--
11. Set and mark cores into their required positions.	5/6
12. Cut each core 300mm above its connection point.	--
13. Place a connector on each bushing, measure and mark internal depth of barrel onto outside of connector.	--
Note: - This mark becomes the reference point for the procedure.	
14. Remove oversheaths and bedding tapes.	17
15. Abrade oversheaths the full length of gland.	18
16. Apply a tum of mastic tape around oversheaths.	--

JOINTING PROCEDURE 7.403 – Continued

Actions	General Requirements (ST: CA3C/3)
17. Straighten copper screen wires and bend back over oversheath termination ensuring copper wire screens are spaced evenly and bedded into mastic tape applied in 16.	--
18. Apply three turns of 20 swg binder over copper screen wires at a point 500mm down from the reference point.	--
19. Apply a second layer of mastic tape over copper screen wires and mastic tape applied in 16.	--
20. Cover mastic tape seal with two layers of Scotch 88 tape overlapping onto copper screen wires by 5mm.	--
21. Offer cores to reference point marked on connectors, mark and cut the cores.	27
22. Offer cores to reference point marked on connectors, mark and cut cores.	--
23. Remove semi-conducting screens ensuring insulation is free from all conductive material.	25
24. Remove connectors from bushings or flexibles and connect to phase conductors, ensure connector palm is in correct position to the bushings or flexibles before shearing bolts.	33
25. Apply termination bodies.	50
26. Apply build up tape to centralise cable within gland.	56
27. Fit gland plate to cable box.	--
28. Position heat shrink breakout over gland and shrink into position.	45
29. Position cores into their final position maintaining a gap between each core and gland inner face.	--
30. Connect phase connectors to bushings or flexibles	--
31. Fill gland with "Lovifit" glue and allow to harden.	39
32. Form copper screen wire bunches into one conductor terminating into an earth connector, and connect to earth stud.	36

JOINTING PROCEDURE 7.403 – Continued

Actions	General Requirements (ST: CA3C/3)
33. Connect switchgear/transformer earth to gland plate earth stud.	--
Note: - For Island layer assemblies the earth must be insulated from the cable box steelwork.	
34. Remove temporary earth continuity bond applied in 7 and reseal oversheaths.	11/45
35. Replace cable box cover ensuring all external bolt threads are treated with “Copaslip” paste.	--
36. Fill cable box with Lovisil compound to required level and replace filling cover; ensure external bolt threads are treated with “Copaslip” paste.	--
37. Mix and dispose correctly the un-used Pu resin.	--

All dimensions in mm

Note :- 185mm² Conductor X = 65
 240/400/630mm² Conductor X = 70

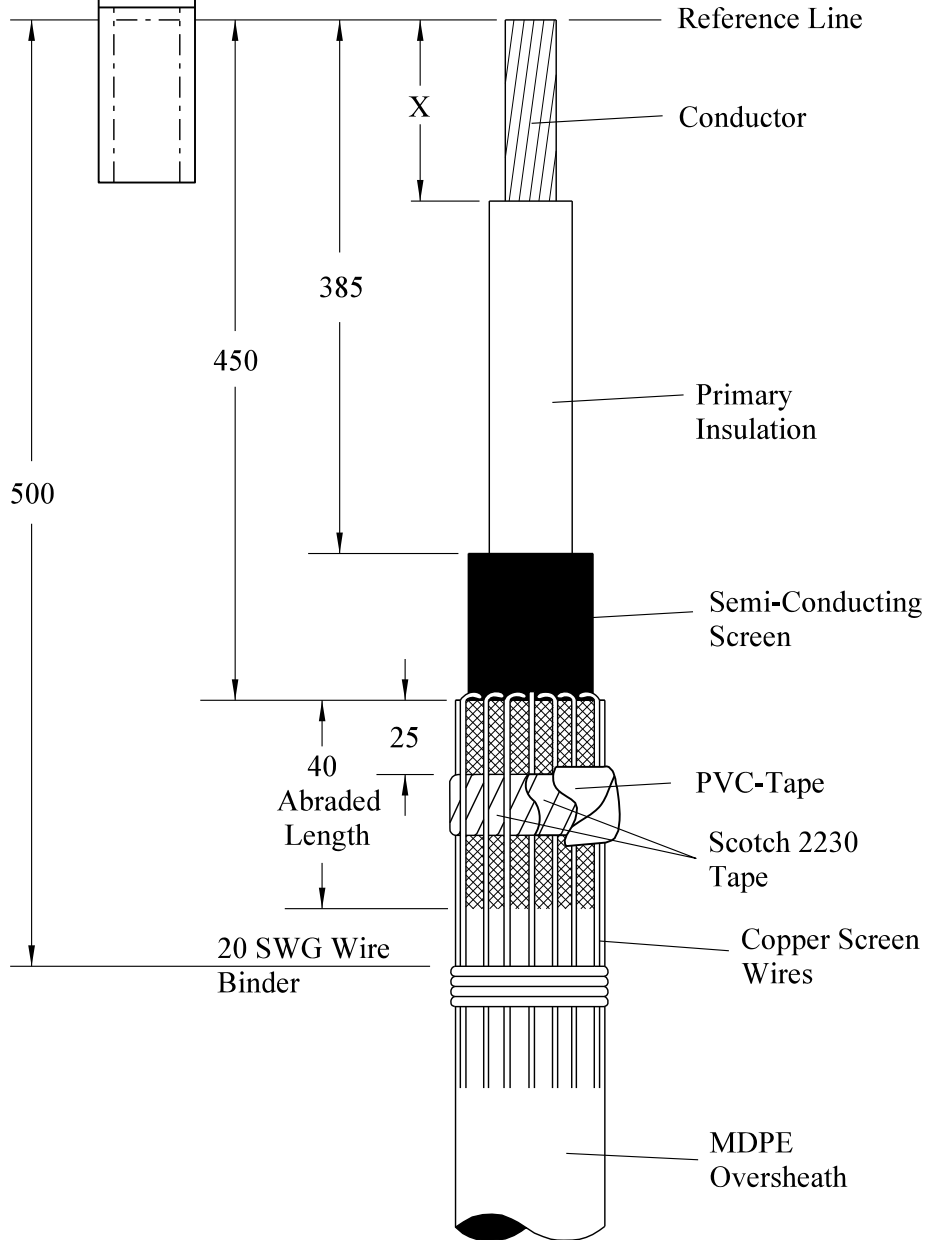



Rev No	Drawn	Chk'd	App'd	Date	Revision	
ORIGINAL ISSUE	DATE	WESTERN POWER DISTRIBUTION Design Department. Avonbank, Feeder Road, Bristol BS2 0TB Tel: 0117 933 2000 Fax: 0117 933 2001.				
Drawn	RJB	03/17	Title			
Checked			185/300mm ²		Drg. No.	Rev No
Approved			COMPOUND FILLED TERMINATION		JP3D 7.403.1	
SCALE	N.T.S.					

ALL RIGHTS ARE RESERVED TO WPD (South West) plc. NO PART OF THIS DRAWING MAY BE REPRODUCED OR TRANSMITTED IN ANY FORM OR BY ANY MEANS, INCLUDING PHOTOCOPYING AND RECORDING, OR STORED IN A RETRIEVAL SYSTEM OF ANY NATURE, WITHOUT PERMISSION.

All dimensions in mm

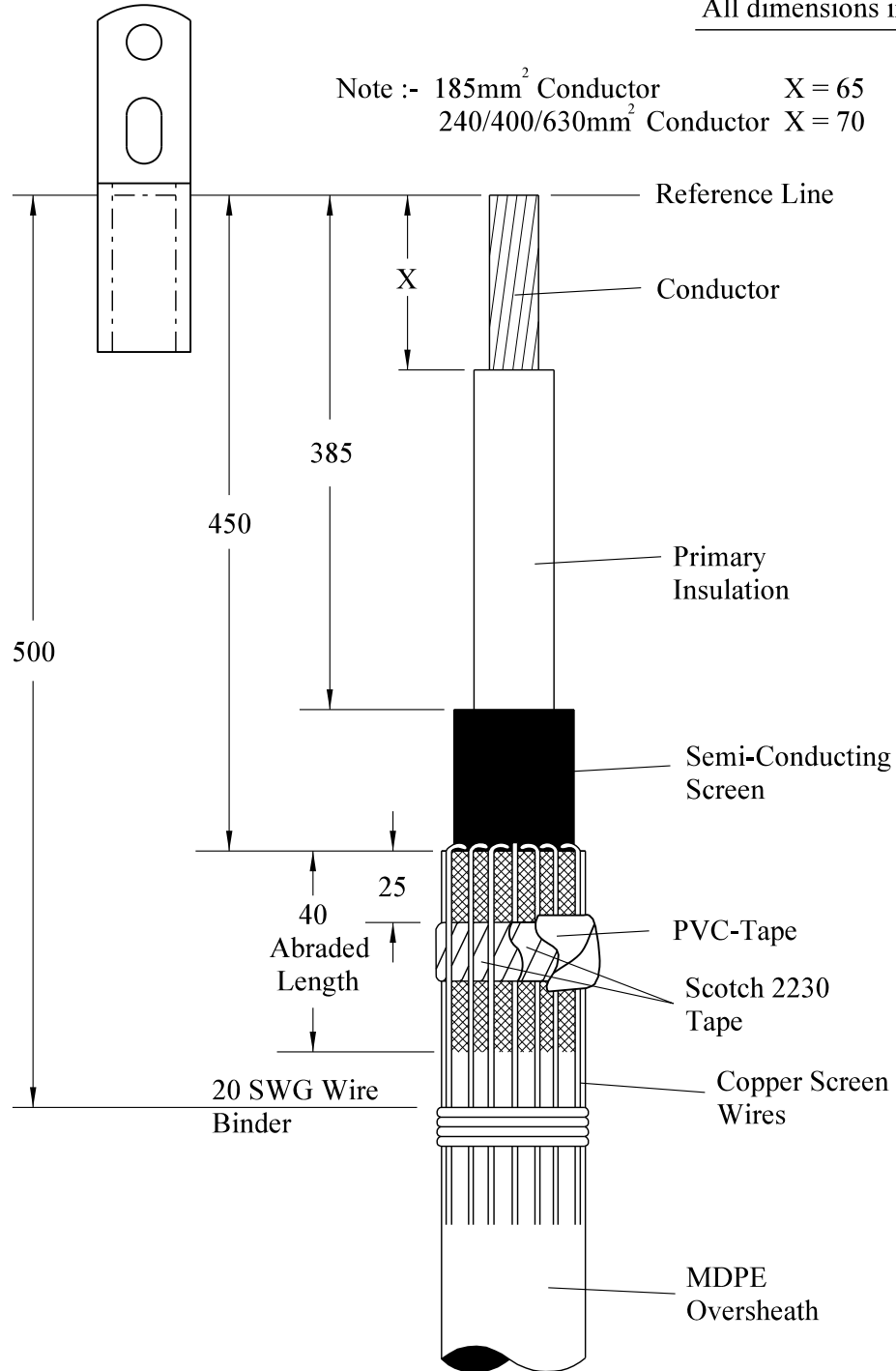
Note :- 185mm² Conductor X = 65
 240/400/630mm² Conductor X = 70



Rev No	Drawn	Chk'd	App'd	Date	Revision	
ORIGINAL ISSUE	DATE	WESTERN POWER DISTRIBUTION Design Department. Avonbank, Feeder Road, Bristol BS2 0TB Tel: 0117 933 2000 Fax: 0117 933 2001.			 WESTERN POWER DISTRIBUTION	
Drawn	RJB	03/17	Title			
Checked			400/630mm ²		JP3D 7.404.1	
Approved			COMPOUND FILLED TERMINATION			
SCALE	N.T.S.					

ALL RIGHTS ARE RESERVED TO WPD (South West) p.l.c. NO PART OF THIS DRAWING MAY BE REPRODUCED OR TRANSMITTED IN ANY FORM OR BY ANY MEANS, INCLUDING PHOTOCOPYING AND RECORDING, OR STORED IN A RETRIEVAL SYSTEM OF ANY NATURE, WITHOUT PERMISSION.

All dimensions in mm

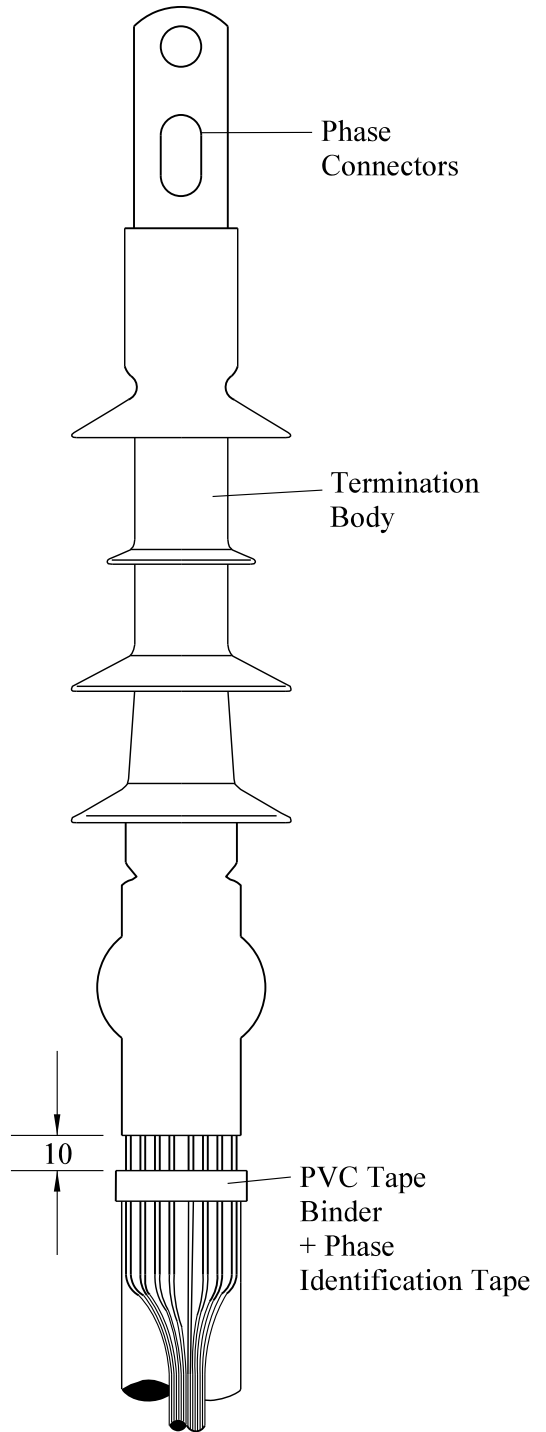
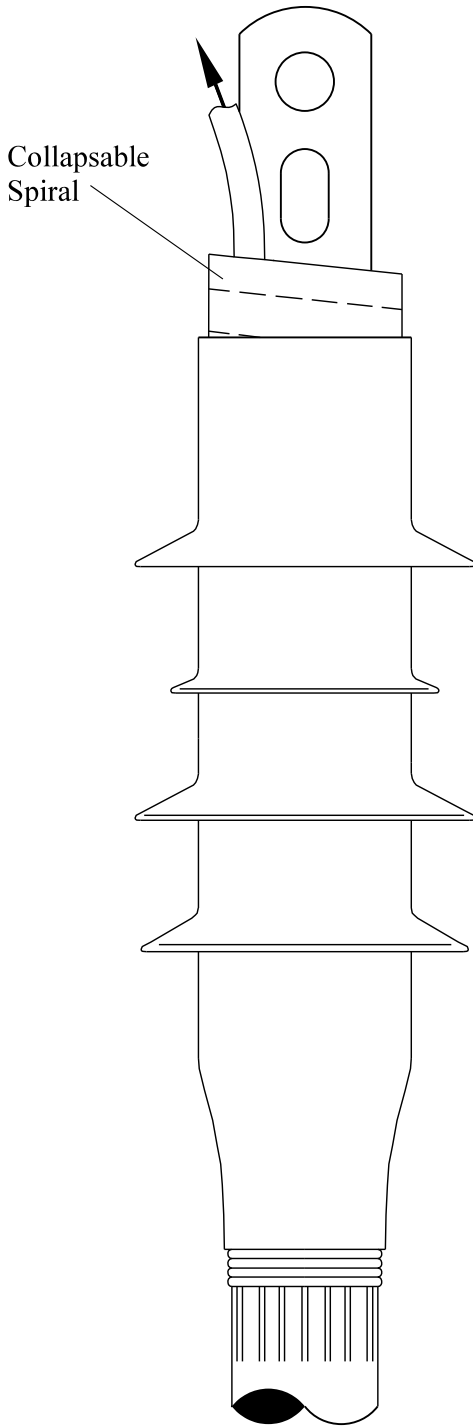



Rev No	Drawn	Chk'd	App'd	Date	Revision	
ORIGINAL ISSUE	DATE	WESTERN POWER DISTRIBUTION Design Department. Avonbank, Feeder Road, Bristol BS2 0TB Tel: 0117 933 2000 Fax: 0117 933 2001.				
Drawn	RJB	01/07	Title			
Checked			GENERAL LAYOUT 185/630mm ² COMPOUND FILLED TERMINATION		JP3D 7.403.2	
Approved						
SCALE	N.T.S.					

ALL RIGHTS ARE RESERVED TO WPD (South West) plc. NO PART OF THIS DRAWING MAY BE REPRODUCED OR TRANSMITTED IN ANY FORM OR BY ANY MEANS, INCLUDING PHOTOCOPYING AND RECORDING, OR STORED IN A RETRIEVAL SYSTEM OF ANY NATURE, WITHOUT PERMISSION.

All dimensions in mm

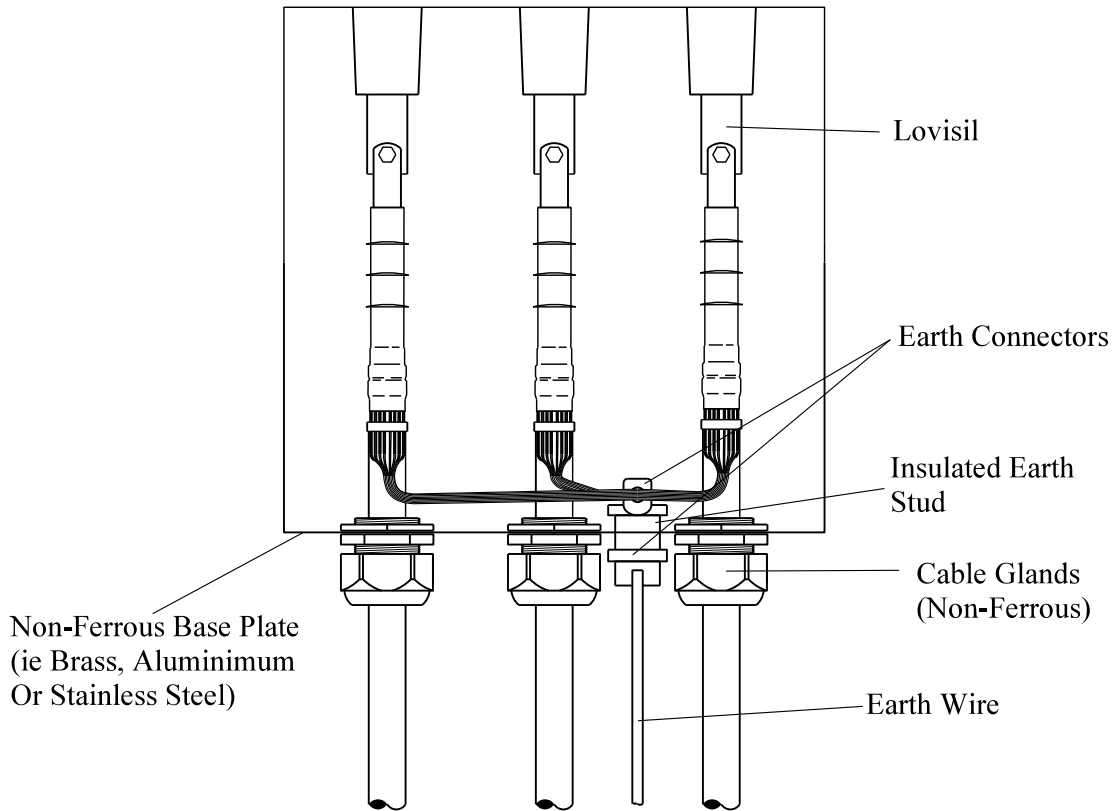
Inline Bushings



Rev No	Drawn	Chk'd	App'd	Date	Revision		
ORIGINAL ISSUE	DATE	WESTERN POWER DISTRIBUTION Design Department. Avonbank, Feeder Road, Bristol BS2 0TB Tel: 0117 933 2000 Fax: 0117 933 2001.					
Drawn	RJB	04/13	Title				Drg. No.
Checked			INDOOR TERMINATION GENERAL LAYOUT			JP3D 7.403.3	
Approved			SCALE			N.T.S.	

ALL RIGHTS ARE RESERVED TO WPD (South West) plc. NO PART OF THIS DRAWING MAY BE REPRODUCED OR TRANSMITTED IN ANY FORM OR BY ANY MEANS, INCLUDING PHOTOCOPYING AND RECORDING, OR STORED IN A RETRIEVAL SYSTEM OF ANY NATURE, WITHOUT PERMISSION.

ST: CA3V/4 PROCEDURES FOR MAKING 33kV CABLE TERMINATIONS

JOINTING PROCEDURE 7.405

**185mm² COPPER WIRE SCREEN 33kV EUROMOLD (M) 430 TB/G
INTERFACE C, 630A, SEPARABLE CONNECTOR TERMINATIONS.**

**This procedure is to be read in conjunction with the appropriate
General Requirements ST: CA3C/3 Section 6
of the 33kV Jointing Manual**

JOINTING PROCEDURE 7.405

TERMINATION KIT MATERIALS LIST

CABLE SIZES —185mm² Single core

Item	Quantity
M 430 TB / G Series Separable Connector 630A (set of 3)	1
Connector BET 120-12 or BET 35-12	1
Atlas cable cleat AR2-A13-TB	3

ADDITIONAL ITEMS FOR EACH TERMINATION

PVC tape
Scotch 70
Scotch 13 tape
Tinned copper wire 16 swg
Tinned copper wire 20 swg
De-solvit 1000 FD
De-solvit 1000
Workhorse dry wipes
Emery cloth
5313 Water block tape
Cable ties
Sealing putty
Aluminium oxide cloth 320 grit
Aluminium oxide cloth 400 grit
Copaslip

Note: - Individual material item numbers (E 5) are to be found in Section 4 of the 33kV Jointing Manual.

JOINTING PROCEDURE 7.405

Actions	General Requirement (ST: CA3C/3)
Refer to Drawings JP3D 7.405.1, 7.405.2, 7.405.3, 7.405.4, 7.405.5, 7.405.6, 7.405.7, 7.405.8 and 7.405.9 whilst undertaking this Jointing Procedure.	
1. Ensure cable box dimensions are suitable for termination.	--
2. Identify and mark core phasing clear of termination position.	--
3. Set and align cores into their termination positions.	5/6
4. Clean each oversheath for a distance of 2m.	--
5. Apply a temporary earth continuity bond clear of termination position.	11
6. Park a mastic lined heat shrink tube next to temporary earth continuity bond of each core.	--
7. Park a compression gland and gland plate over each core.	--
8. Set and mark cores into their required positions.	5/6
9. Cut each core 500mm above its connection point ensuring a sufficient length of the copper screen wires for connection to cable box earth stud.	--
10. Place a connector onto each bushing, measure and mark internal depth of barrel onto outside of connector.	--
Note: - This mark becomes the reference point for the procedure.	
11. Remove oversheaths and bedding tapes.	17
12. Abrade oversheaths.	18
13. Apply a turn of mastic tape around oversheath.	--
14. Straighten copper screen wires and bend back over oversheath termination ensure copper screen wires are spaced evenly into mastic tape applied in 13.	--
15. Apply three turns of 20swg binder over copper screen wires at a point 275mm down from the reference point.	--
16. Place a PVC tape marker 300mm from the reference point onto the copper screen wires.	--

JOINTING PROCEDURE 7.405 - Continued

Actions	General Requirement (ST: CA3C/3)
17. Offer cores to reference point marked on connectors, mark and cut cores.	--
18. Remove semi-conducting screens, ensuring insulation is free from all conductive material.	25
19. Remove core insulation making a 3mm bevel to insulation end.	28
20. Apply a few turns of PVC tape to the conductor end as protection.	--
21. Thoroughly clean core insulation.	--
22. Apply field control mastic strip, type MFC, slightly stretch one end applying with a 5mm overlap onto both semi-conducting screen and core insulation, push the mastic in place while stretching it progressively until both ends overlap and tear-off excess mastic.	--
Note: - Ensure mastic does not break during application.	
23. Apply the insulation coned rod to conductor end, thoroughly clean coned rod and lubricate coned rod and core up to the MFC mastic tape.	--
Note: - Alternatively the conductor can be coned using PVC tape adhesive side up to start and tapered to insulation diameter, it is important to apply a cover to the stranded conductor to prevent internal damage to the bore of the reducer when applied.	
24. Lubricate internal face (stepped end of the cable reducer, slide reducer down the core without hesitation and in one smooth movement until the end reaches the PVC tape marker applied in 16.	--
25. Remove connectors from bushings and connect to phase conductors, ensure connector palm is in correct position to bushings before shearing bolts.	33
Note: - <u>Check distance between top of connector and top of reducer is between 150 and 160mm. Adjust the reducer to suit.</u>	
26. Clean cable reducer, core insulation and connector.	--
27. Lightly lubricate the inner surface of the tee connector housing and cable reducer.	--

JOINTING PROCEDURE 7.405 - Continued

Actions	General Requirement (ST: CA3C/3)
28. Check the angle of the tee connector housing is correct to connector palm and longer interface is pointing towards the bushing. Whilst supporting the cable reducer at its stepped end preventing movement, gently slide the housing onto the cable until it cannot advance any further. Check correct installation by trying to pull back the connector, it is correct when it stays in its locked position, also check to ensure cable reducer has stayed in place during installation.	--
29. Clean and lightly lubricate both inner face of connector housing and bushing, push connector housing onto bushing.	--
30. Insert clamping screw (longer thread) into threaded hole of bushing and tighten.	--
Note: - The screw must be tightened with a torque wrench exerting 50Nm of torque using a 22mm socket in order to achieve correct torque, ensure there is to be no lubrication on the threaded parts.	
31. Clean and lubricate plug and inner face of connector housing.	--
32. Insert the plug into connector housing and tighten assembly.	--
Note: - The plug must be tightened with a torque wrench exerting 30Nm of torque using a 22mm socket in order to achieve correct torque, ensure there is to be no lubrication on the threaded parts.	
33. Clean inside of protective cap and outer face of connector housing and insulating plug.	--
34. Push protective cap over connector housing onto the insulating plug, slightly pull the edge of the protective cap to exhaust any air whilst pressing cap centre onto its locking point until it snaps into place. Position cap with the pulling tab facing downwards.	--
35. Apply four turns of Scotch tape of the relevant phase colour around the copper the screen wires 10mm below cable reducer end.	--
Note: - Do not apply PVC tape to cable reducer or connector housing.	
36. Form copper screen wires into a bunch, remove 20swg binder and PVC tape binder applied in 15/16.	--

JOINTING PROCEDURE 7.405 - Continued

Actions	General Requirement (ST: CA3C/3)
37. Fit gland plate to cable box.	--
38. Fit compression gland to each core.	54
39. Form copper screen wires bunches into one conductor terminating into a terminating into an earth connector, and connect to earth stud.	--
40. Connect earth leads from connector housings to earth stud.	--
41. Fit and secure cables into cable cleats.	--
42. Connect switchgear/transformer earth to gland plate earth stud.	--
43. Remove temporary earth continuity bond applied in 5 and reseal oversheaths with heat shrink tubes applied in 6.	11/45
44. Replace cable box cover ensuring all external bolt threads are treated with "Copaslip" paste and security bolts are in place.	--

All Dimensions in mm

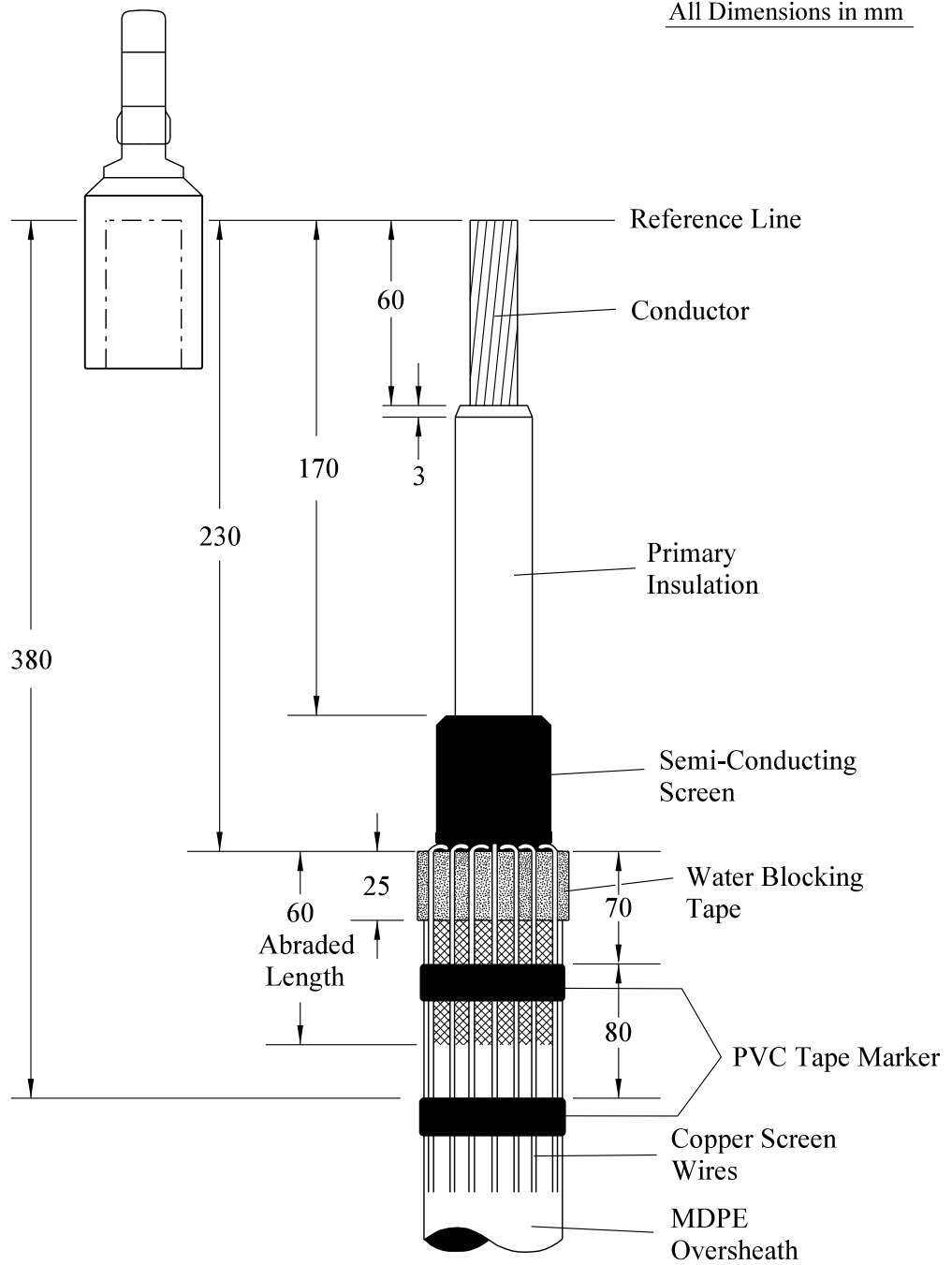



Fig 1

1	RJB			05/17	DIMENSIONS ALTERED	
Rev No	Drawn	Chk'd	App'd	Date	Revision	
ORIGINAL ISSUE	DATE	WESTERN POWER DISTRIBUTION Design Department. Avonbank, Feeder Road, Bristol BS2 0TB Tel: 0117 933 2000 Fax: 0117 933 2001.				
Drawn	RJB	03/17	Title			
Checked			M430TBG TEE CONNECTOR TERMINATION STRIPPING DIMENSIONS			Drg. No.
Approved						JP3D 7.405.1
SCALE	N.T.S.					Rev No
						1

ALL RIGHTS ARE RESERVED TO WPD (South West) plc. NO PART OF THIS DRAWING MAY BE REPRODUCED OR TRANSMITTED IN ANY FORM OR BY ANY MEANS, INCLUDING PHOTOCOPYING AND RECORDING, OR STORED IN A RETRIEVAL SYSTEM OF ANY NATURE, WITHOUT PERMISSION.

All Dimensions in mm

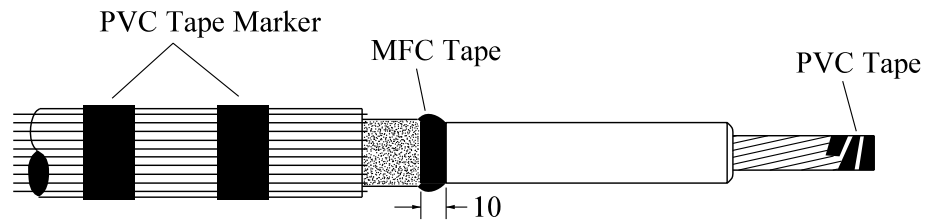

Fig 2

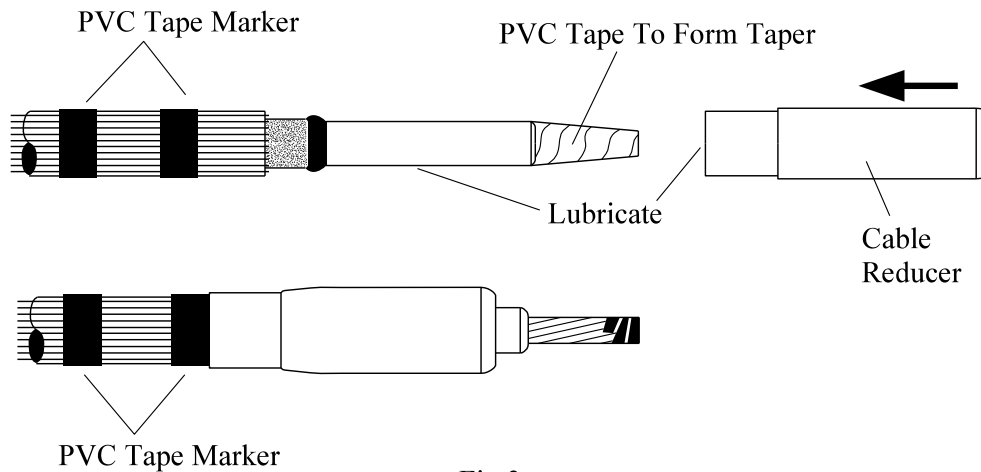



Fig 3

Rev No	Drawn	Chk'd	App'd	Date	Revision		
ORIGINAL ISSUE	DATE	WESTERN POWER DISTRIBUTION Design Department. Avonbank, Feeder Road, Bristol BS2 0TB Tel: 0117 933 2000 Fax: 0117 933 2001.					
Drawn	RJB	03/17	Title				Drg. No.
Checked			M430TBG TEE CONNECTOR TERMINATION TERMINATION COMPLETION			JP3D 7.405.2	
Approved							
SCALE	N.T.S.						

ALL RIGHTS ARE RESERVED TO WPD (South West) plc. NO PART OF THIS DRAWING MAY BE REPRODUCED OR TRANSMITTED IN ANY FORM OR BY ANY MEANS, INCLUDING PHOTOCOPYING AND RECORDING, OR STORED IN A RETRIEVAL SYSTEM OF ANY NATURE, WITHOUT PERMISSION.

All Dimensions in mm

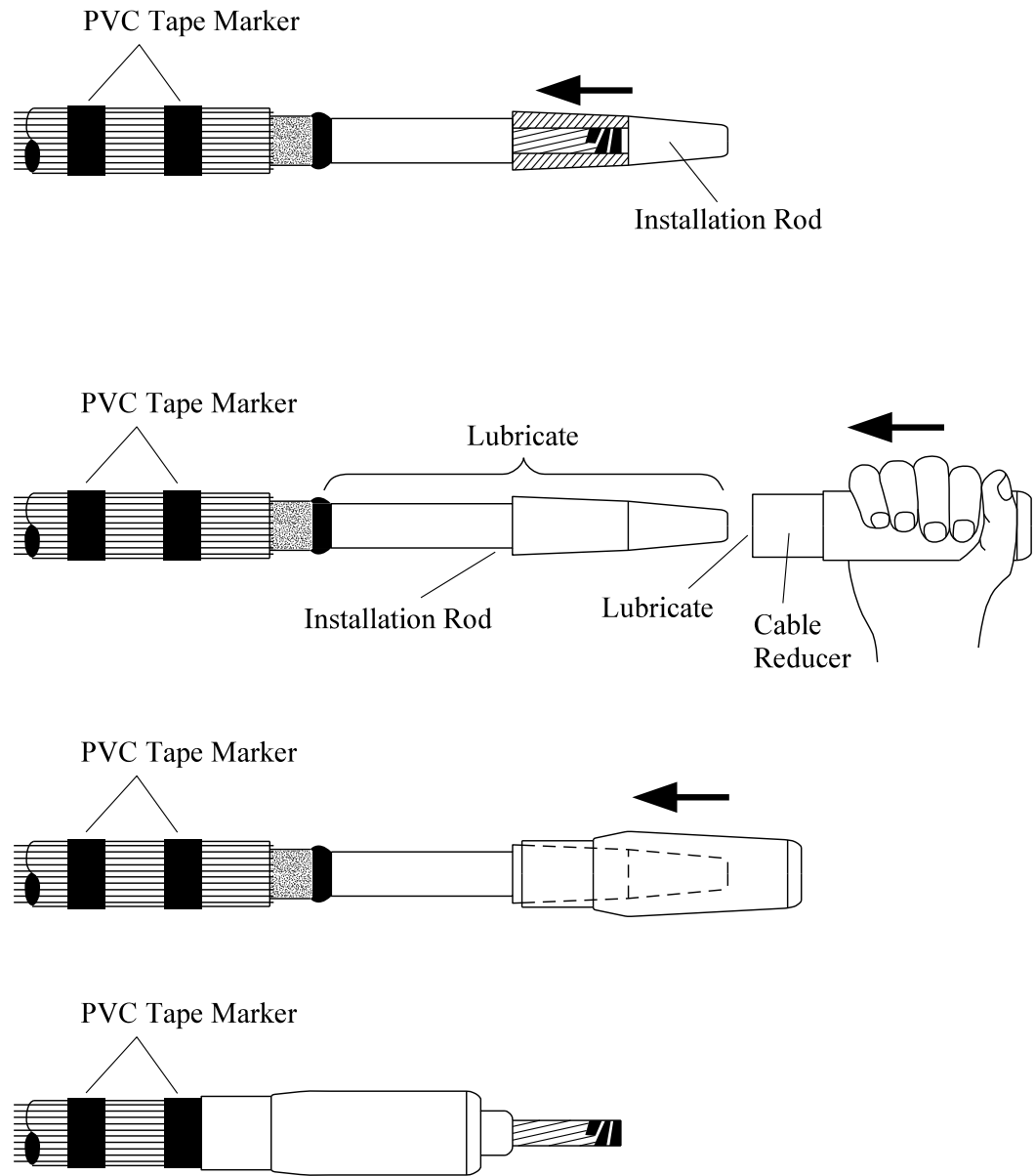



Fig 4

Rev No	Drawn	Chk'd	App'd	Date	Revision		
ORIGINAL ISSUE	DATE	WESTERN POWER DISTRIBUTION Design Department. Avonbank, Feeder Road, Bristol BS2 0TB Tel: 0117 933 2000 Fax: 0117 933 2001.					
Drawn	RJB	03/17	Title				
Checked			M430TBG TEE CONNECTOR TERMINATION TERMINATION COMPLETION			Drg. No.	Rev No
Approved						JP3D 7.405.3	
SCALE	N.T.S.						

ALL RIGHTS ARE RESERVED TO WPD (South West) plc. NO PART OF THIS DRAWING MAY BE REPRODUCED OR TRANSMITTED IN ANY FORM OR BY ANY MEANS, INCLUDING PHOTOCOPYING AND RECORDING, OR STORED IN A RETRIEVAL SYSTEM OF ANY NATURE, WITHOUT PERMISSION.

All Dimensions in mm

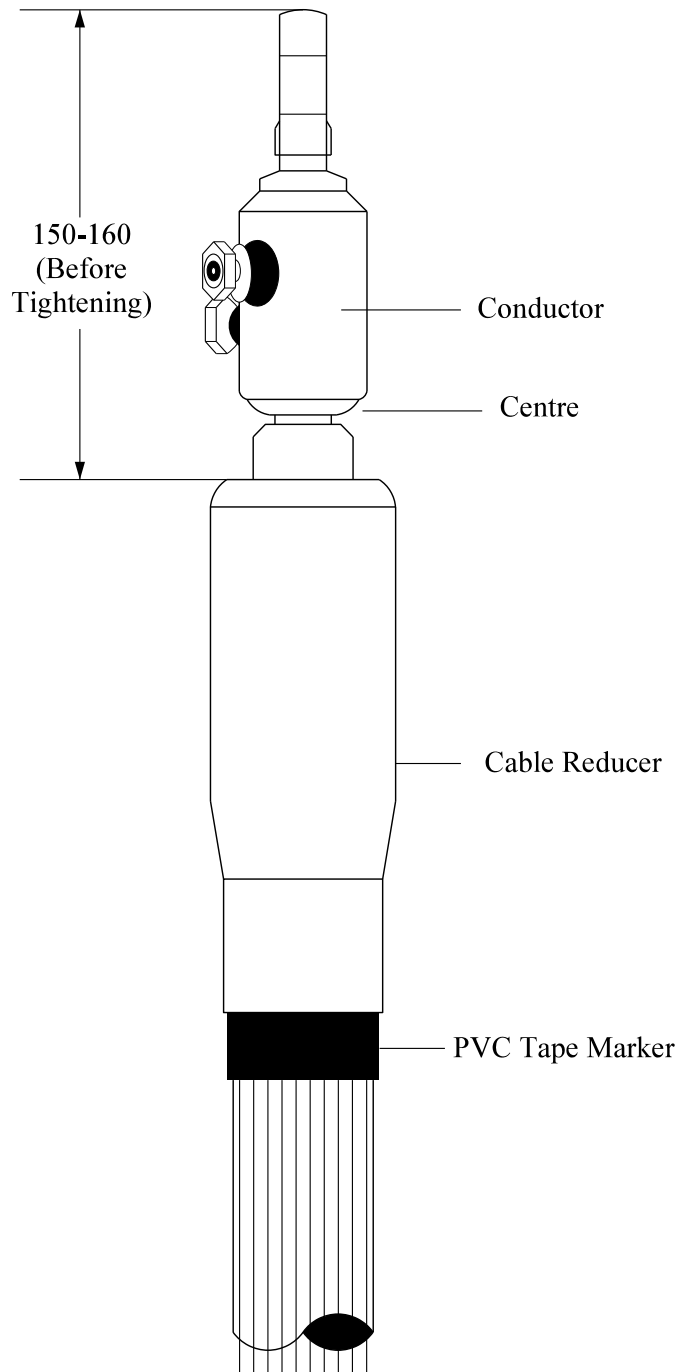

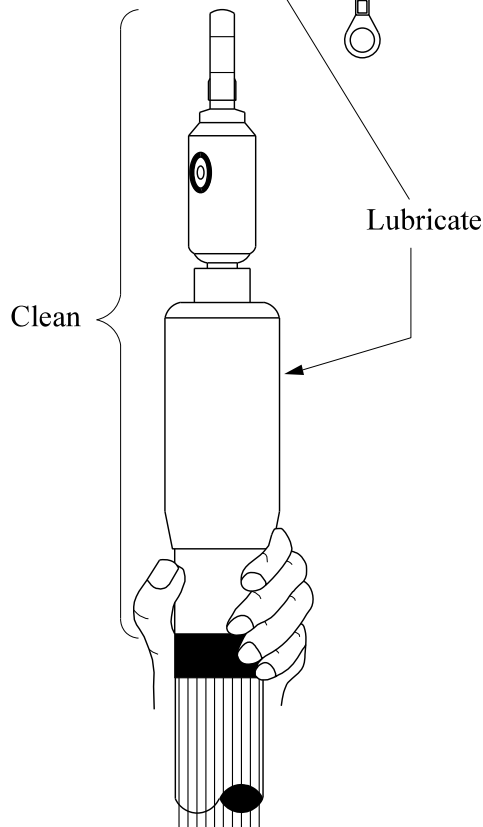
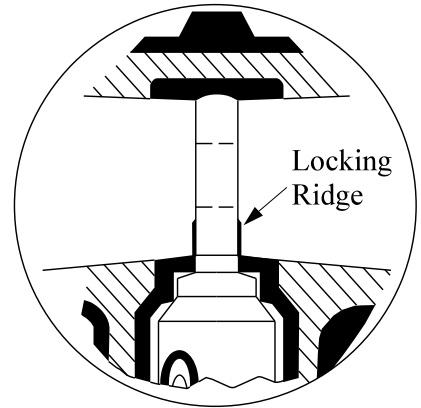
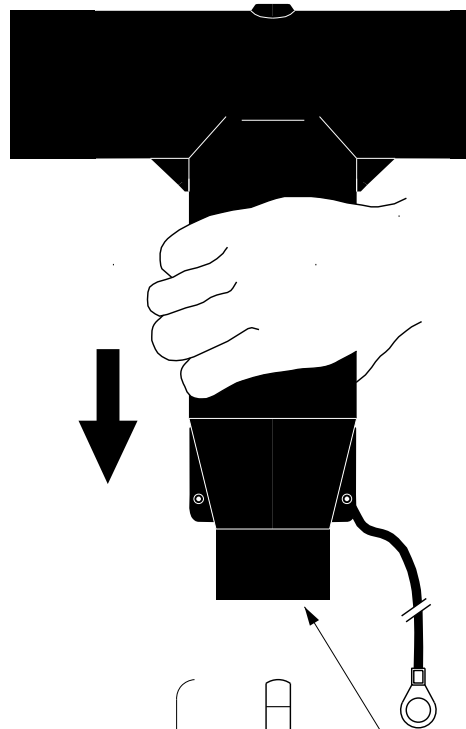



Fig 5

Rev No	Drawn	Chk'd	App'd	Date	Revision	
ORIGINAL	ISSUE	DATE	WESTERN POWER DISTRIBUTION Design Department. Avonbank, Feeder Road, Bristol BS2 0TB Tel: 0117 933 2000 Fax: 0117 933 2001.			
Drawn	RJB	03/17	Title			
Checked			M430TBG TEE CONNECTOR TERMINATION TERMINATION COMPLETION			Drg. No.
Approved						Rev No
SCALE	N.T.S.					JP3D 7.405.4

ALL RIGHTS ARE RESERVED TO WPD (South West) plc. NO PART OF THIS DRAWING MAY BE REPRODUCED OR TRANSMITTED IN ANY FORM OR BY ANY MEANS, INCLUDING PHOTOCOPYING AND RECORDING, OR STORED IN A RETRIEVAL SYSTEM OF ANY NATURE, WITHOUT PERMISSION.

All Dimensions in mm



Rev No	Drawn	Chk'd	App'd	Date	Revision	
ORIGINAL ISSUE	DATE	WESTERN POWER DISTRIBUTION Design Department. Avonbank, Feeder Road, Bristol BS2 0TB Tel: 0117 933 2000 Fax: 0117 933 2001.				
Drawn	RJB 03/17	Title				
Checked		M430TBG TEE CONNECTOR TERMINATION			JP3D 7.405.5	
Approved						
SCALE	N.T.S.					

ALL RIGHTS ARE RESERVED TO WPD (South West) plc. NO PART OF THIS DRAWING MAY BE REPRODUCED OR TRANSMITTED IN ANY FORM OR BY ANY MEANS, INCLUDING PHOTOCOPYING AND RECORDING, OR STORED IN A RETRIEVAL SYSTEM OF ANY NATURE, WITHOUT PERMISSION.

All dimensions in mm

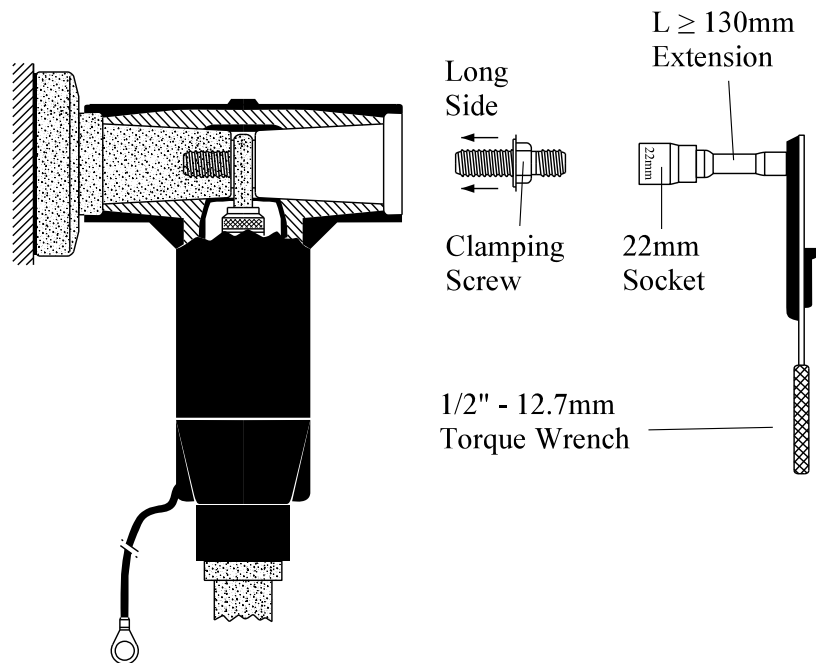
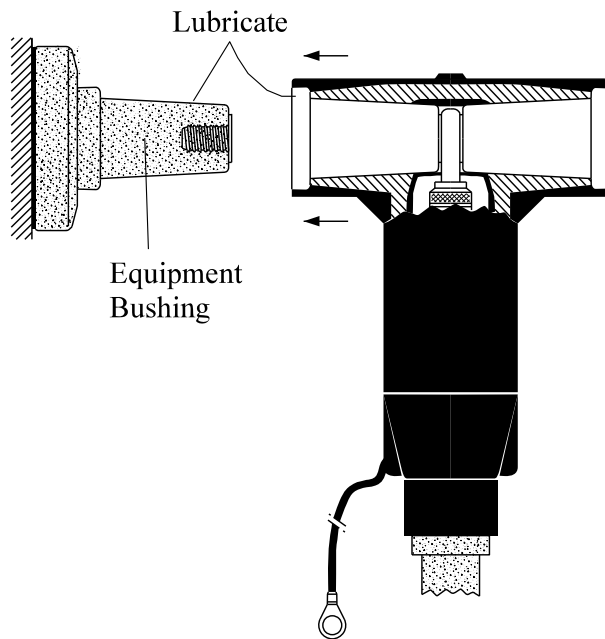

Rev No	Drawn	Chk'd	App'd	Date	Revision	
ORIGINAL ISSUE	DATE	WESTERN POWER DISTRIBUTION Design Department. Avonbank, Feeder Road, Bristol BS2 0TB Tel: 0117 933 2000 Fax: 0117 933 2001.				
Drawn	RJB	04/13	Title			
Checked			M430TBG TEE CONNECTOR TERMINATION TERMINATION BOLTING TOGETHER		JP3D 7.405.6	
Approved						
SCALE	N.T.S.					

ALL RIGHTS ARE RESERVED TO WPD (South West) plc. NO PART OF THIS DRAWING MAY BE REPRODUCED OR TRANSMITTED IN ANY FORM OR BY ANY MEANS, INCLUDING PHOTOCOPYING AND RECORDING, OR STORED IN A RETRIEVAL SYSTEM OF ANY NATURE, WITHOUT PERMISSION.

All dimensions in mm

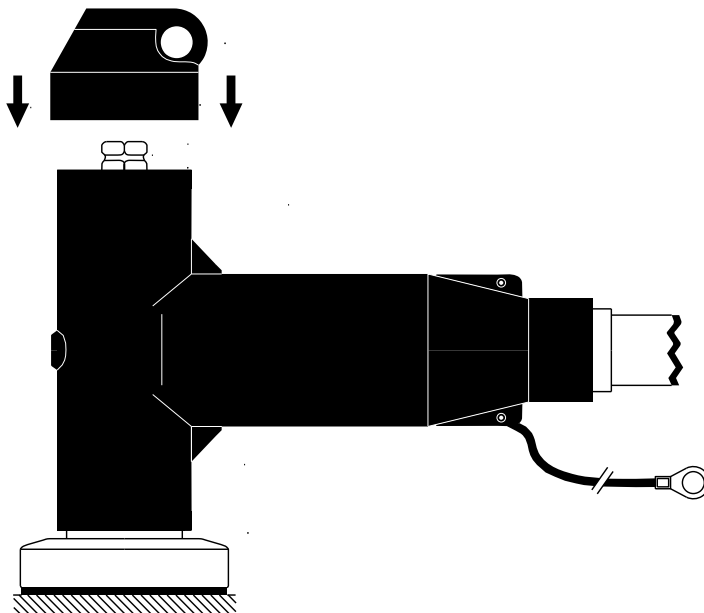
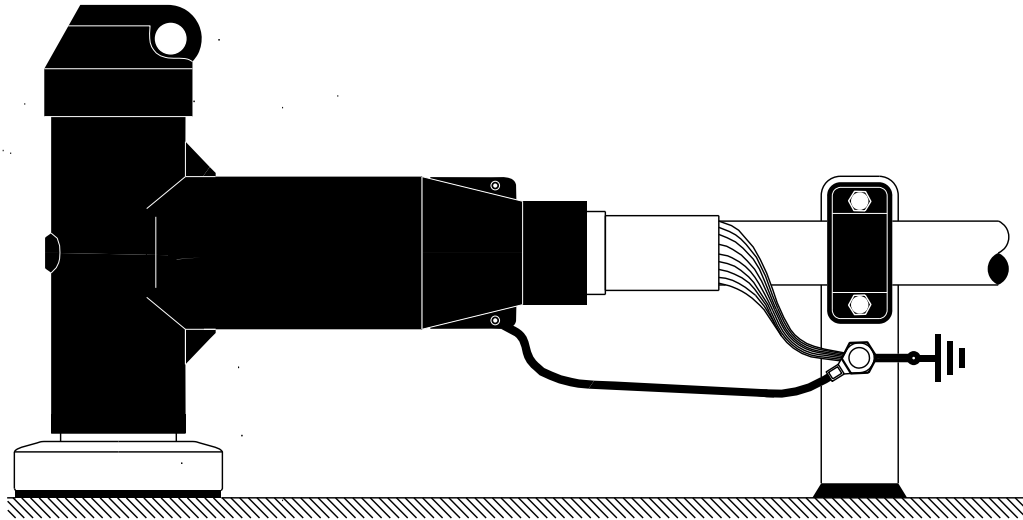

Rev No	Drawn	Chk'd	App'd	Date	Revision	
ORIGINAL ISSUE	DATE	WESTERN POWER DISTRIBUTION Design Department. Avonbank, Feeder Road, Bristol BS2 0TB Tel: 0117 933 2000 Fax: 0117 933 2001.				
Drawn	RJB	03/17	Title			
Checked			M430 SEPARABLE TEE CONNECTOR TERMINATION COMPLETION		JP3D 7.405.7	
Approved						
SCALE	N.T.S.					

ALL RIGHTS ARE RESERVED TO WPD (South West) plc. NO PART OF THIS DRAWING MAY BE REPRODUCED OR TRANSMITTED IN ANY FORM OR BY ANY MEANS, INCLUDING PHOTOCOPYING AND RECORDING, OR STORED IN A RETRIEVAL SYSTEM OF ANY NATURE, WITHOUT PERMISSION.

All dimensions in mm

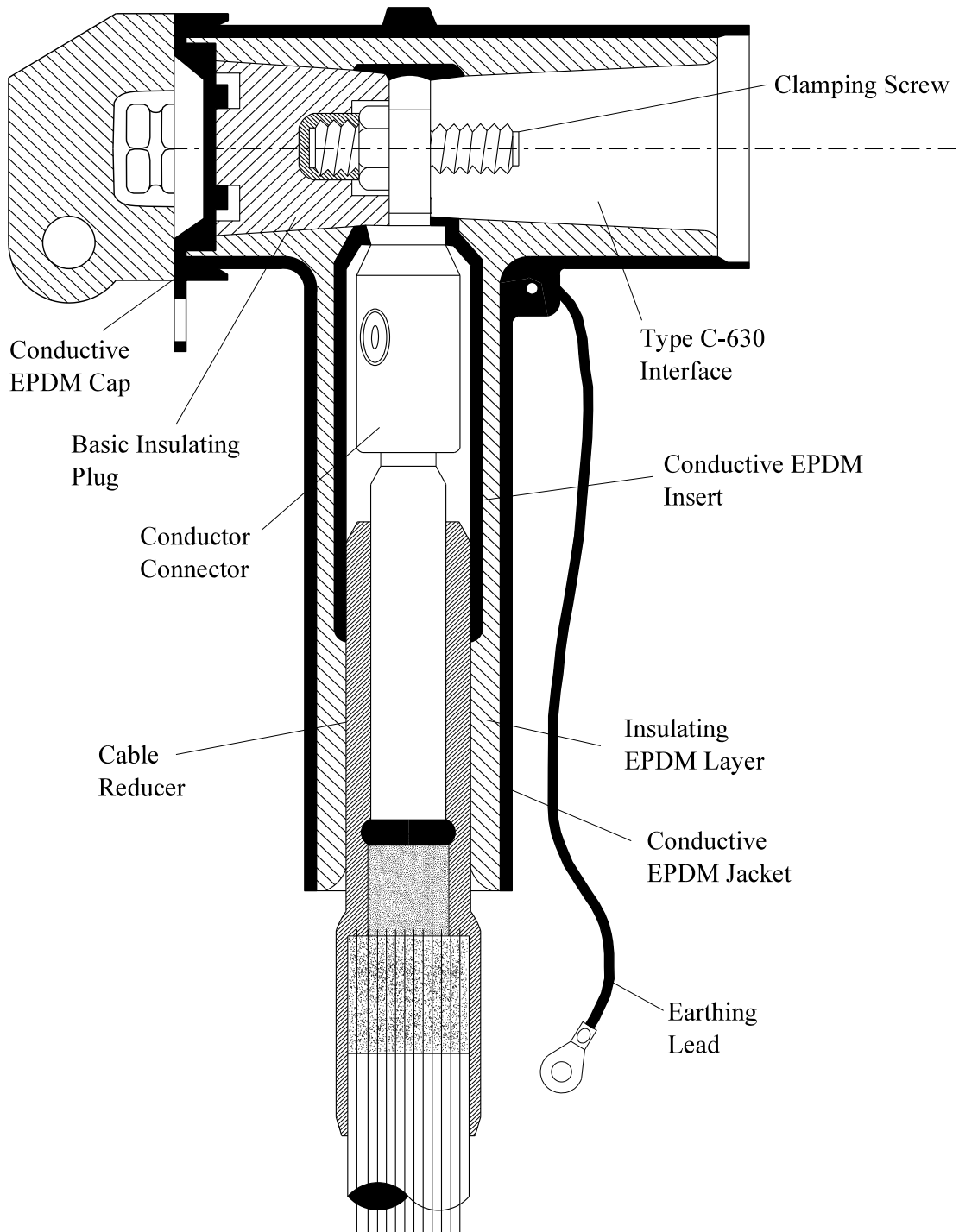



Fig 8

Rev No	Drawn	Chk'd	App'd	Date	Revision	
ORIGINAL ISSUE	DATE	WESTERN POWER DISTRIBUTION Design Department. Avonbank, Feeder Road, Bristol BS2 0TB Tel: 0117 933 2000 Fax: 0117 933 2001.				
Drawn	RJB	03/17	Title			
Checked			M430TBG TEE CONNECTOR TERMINATION TERMINATION COMPLETION		JP3D 7.405.8	
Approved						
SCALE	N.T.S.					

ALL RIGHTS ARE RESERVED TO WPD (South West) plc. NO PART OF THIS DRAWING MAY BE REPRODUCED OR TRANSMITTED IN ANY FORM OR BY ANY MEANS, INCLUDING PHOTOCOPYING AND RECORDING, OR STORED IN A RETRIEVAL SYSTEM OF ANY NATURE, WITHOUT PERMISSION.

All dimensions in mm

Right Angle Bushings

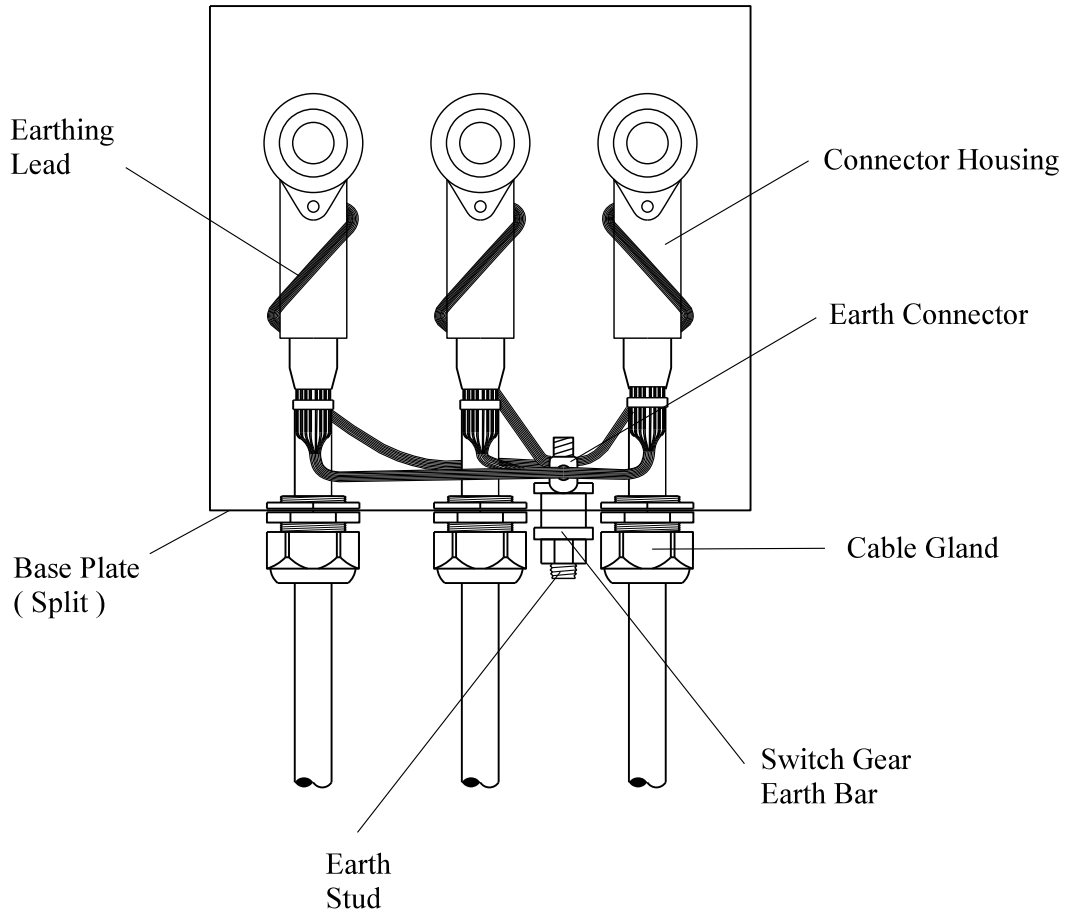

Rev No	Drawn	Chk'd	App'd	Date	Revision	
ORIGINAL ISSUE	DATE	WESTERN POWER DISTRIBUTION Design Department. Avonbank, Feeder Road, Bristol BS2 0TB Tel: 0117 933 2000 Fax: 0117 933 2001.				
Drawn	RJB	04/13	Title			
Checked			M430TBG TEE CONNECTOR TERMINATION EQUALISATION BONDING ARRANGEMENT.		JP3D 7.405.9	
Approved						
SCALE	N.T.S.					

ALL RIGHTS ARE RESERVED TO WPD (South West) plc. NO PART OF THIS DRAWING MAY BE REPRODUCED OR TRANSMITTED IN ANY FORM OR BY ANY MEANS, INCLUDING PHOTOCOPYING AND RECORDING, OR STORED IN A RETRIEVAL SYSTEM OF ANY NATURE, WITHOUT PERMISSION.

ST: CA3V/4 PROCEDURES FOR MAKING 33kV CABLE TERMINATIONS

JOINTING PROCEDURE 7.406

**300/400/630 and 800mm² COPPER WIRE SCREEN CABLE 33kV EUROMOLD
(M) 440 TB/G INTERFACE C SEPARABLE CONNECTOR TERMINATIONS.**

**This procedure is to be read in conjunction with the appropriate
General Requirements ST: CA3C/3 Section 6
of the 33kV Jointing Manual**

JOINTING PROCEDURE 7.406

TERMINATION KIT MATERIALS LIST

CABLE SIZES — 300mm²

Item	Quantity
(M)440TB/G-32-120.300-14.5MWS Separable Connector 630A (each)	3
Connector BET 120-12 or BET 35-12	3
Cable cleat AR2-A13-TB	3

CABLE SIZES — 400mm² CWS

Item	Quantity
(M)440TB/G-37-TBMC-400.630-12.5MWS Separable Connector 630A (each)	3
Connector BET 120-12 or BET 35-12	3
Cable cleat AR2-A13-TB	3

CABLE SIZES — 630mm² CWS

Item	Quantity
(M)440TB/G-44-TBMC-400.630-12.5.MWS Separable Connector 630A (each)	3
Connector BET 120-12 or BET 35-12	3
Cable cleat AR2-A14-TB	3

CABLE SIZES — 800mm² CWS

Item	Quantity
(M)440TB/G-44-TBMC-400.800-12.5.MWS Separable Connector 630A (each)	3
Connector BET 120-12 or BET 35-12	3
Cable cleat AR2-A14-TB	3

Note: - The 800mm² (M) 440 TB/G uses a compression lug therefore ensure you have the correct compression tool and dies sets before commencing work.

ADDITIONAL ITEMS FOR EACH TERMINATION

PVC tape
Scotch 70
Scotch 13 tape
Tinned copper wire 16 swg
Tinned copper wire 20 swg
De-solvit 1000 FD
De-solvit 1000
Workhorse dry wipes
Emery cloth
5313 Water block tape
Cable ties
Sealing putty
Aluminium oxide cloth 320 grit
Aluminium oxide cloth 400 grit
Copaslip

Note: - Individual material item numbers (E 5) are to be found in Section 4 of the 33kV Jointing Manual.

JOINTING PROCEDURE 7.406

Actions	General Requirement (ST: CA3C/3)
Refer to Drawings JP3D 7.406.1, 7.406.2, 7.406.3 7.406.4, 7.406.5, 7.406.6, 7.406.7 and 7.406.8 whilst undertaking this Jointing Procedure.	
1. Identify and mark core phasing clear of termination position.	--
2. Set and align cables into their termination positions.	--
3. Clean each oversheath for a distance of 1 .5m.	--
4. Apply a temporary earth continuity bond clear of termination position.	11
5. Park a mastic lined heat shrink tube next to temporary earth continuity bond of each core.	--
6. Park a compression gland over each core.	54
7. Set and mark cables into their required positions.	5/6
8. Cut each cable 300mm above its connection point.	--
9. Place a connector on each bushing, measure and mark internal depth of barrel onto outside of connector.	--
This mark becomes the reference point for the procedure.	
10. Remove oversheaths and bedding tapes — Fig 1.	--
11. Abrade oversheaths — Fig 1.	--
12. Apply a turn of mastic around oversheath — Fig 1.	--
13. Straighten copper screen wires and bend back over oversheath termination ensure copper screen wires are spaced evenly and bedded into mastic applied in 11.	--
14. Apply three turns of 20swg binder over copper wires at a point 275mm down from the reference point.	--
15. Place a PVC tape marker 245mm from the reference point onto the copper screen wires — Fig 1.	--
16. Offer cores to reference point marked on connectors, mark and cut cores.	--

JOINTING PROCEDURE 7.406 - Continued

Actions	General Requirement (ST: CA3C/3)
17. Remove semi-conducting screens, ensuring insulation is free from all conductive material — Fig 1.	25
18. Remove core insulation making a 3mm bevel to insulation end — Fig 1.	31
19. Apply a few turns of PVC tape to the conductor end as a protection.	--
20. Thoroughly clean core insulation.	--
21. Apply field control mastic strip, type MFC, slightly stretch one end applying with a 5mm overlap onto both semi-conducting screen and core insulation, push the mastic in place while stretching it progressively until both ends overlap and tear-off excess mastic — Fig 2	--
Note: - Ensure mastic does not break during application.	
22. Apply the installation coned rod to conductor end, thoroughly clean coned rod and lubricate coned rod and core up to the MFC mastic tape — Fig 4.	--
23. Lubricate internal face (stepped end) of the cable reducer, slide cable reducer down the core without hesitation and in one smooth movement until the end reaches the PVC tape marker applied in 9—Fig 4.	--
24. Remove connectors from bushings and connect to phase conductors, ensure connector palm is in correct position to bushings before shearing; before and after shearing <u>check distance between top of shearbolt connector and top of cable reducer is between 155 and 165mm see Fig 5. Adjust the reducer to suit</u>	36
25. Clean cable reducer, core insulation and connector — Fig 6.	--
26. Lightly lubricate the inner surface of the tee connector housing and cable reducer — Fig 6.	--
27. Check the angle of the tee connector housing is correct to connector palm and longer interface is pointing towards the bushing. Whilst supporting the cable reducer at its stepped end preventing movement, gently slide the housing onto the cable until it cannot advance no further — Fig 6.	--
28. Check correct installation by trying to pull back the connector, it is correct when it stays in its locked position, also check to ensure cable reducer has stayed in place during installation — Fig 7.	--

JOINTING PROCEDURE 7.406 - Continued

Actions	General Requirement (ST: CA3C/3)
29. Clean and lightly lubricate both inner face of connector housing and bushing, push connector housing onto bushing.	--
30. Insert clamping screw (longer thread) into threaded hole of bushing and tighten — Fig 8.	--
Note: - The screw must be tighten with a torque wrench exerting a 50Nm of torque using a 22mm socket in order to achieve correct torque, ensure there is to be no lubricate on the threaded parts.	
31. Clean and lubricate plug and inner face of connector housing. Insert nylon venting rod into the connector interface.	--
32. Insert the plug into connector housing, remove nylon venting rod and tighten assembly - Fig 8.	--
Note: - The plug must be tighten with a torque wrench exerting 50Nm of torque using a 22mm socket in order to achieve correct torque, ensure there is to be no lubricate on the threaded parts.	
33. Clean inside of protective cap and outer face of the connector housing and insulating plug.	--
34. Push protective cap over connector housing onto the insulating plug, slightly pull the edge of the protective cap to exhaust any air whilst pressing cap centre onto its locking point until it snaps into place. Position the cap with the pulling tab facing downwards — Fig 8.	--
35. Apply four turns of Scotch tape of the relevant phase colour around copper screen wires 10mm below cable reducer end.	--
Note: - Do not apply PVC tape to cable reducer or connector housing.	
36. Form copper screen wires into a bunch and removing 20swg binder and PVC tape binder applied in 13/14.	--
37. Fit gland plate to cable box.	--
38. Fit compression glands to gland plate and each cable.	60
39. Form copper screen wire bunches into one conductor terminating into a earth connector, and connect to earth stud.	36
40. Remove temporary earth continuity bond applied in 4 and reseal oversheaths.	51

JOINTING PROCEDURE 7.406 - Continued

Actions	General Requirement (ST: CA3C/3)
41. Replace cable box cover ensuring all external bolt threads are treated with “Copaslip” paste and security bolts are in place.	--

All Dimensions in mm

Note:- "X" = Depth Of Connector
Entry + 5

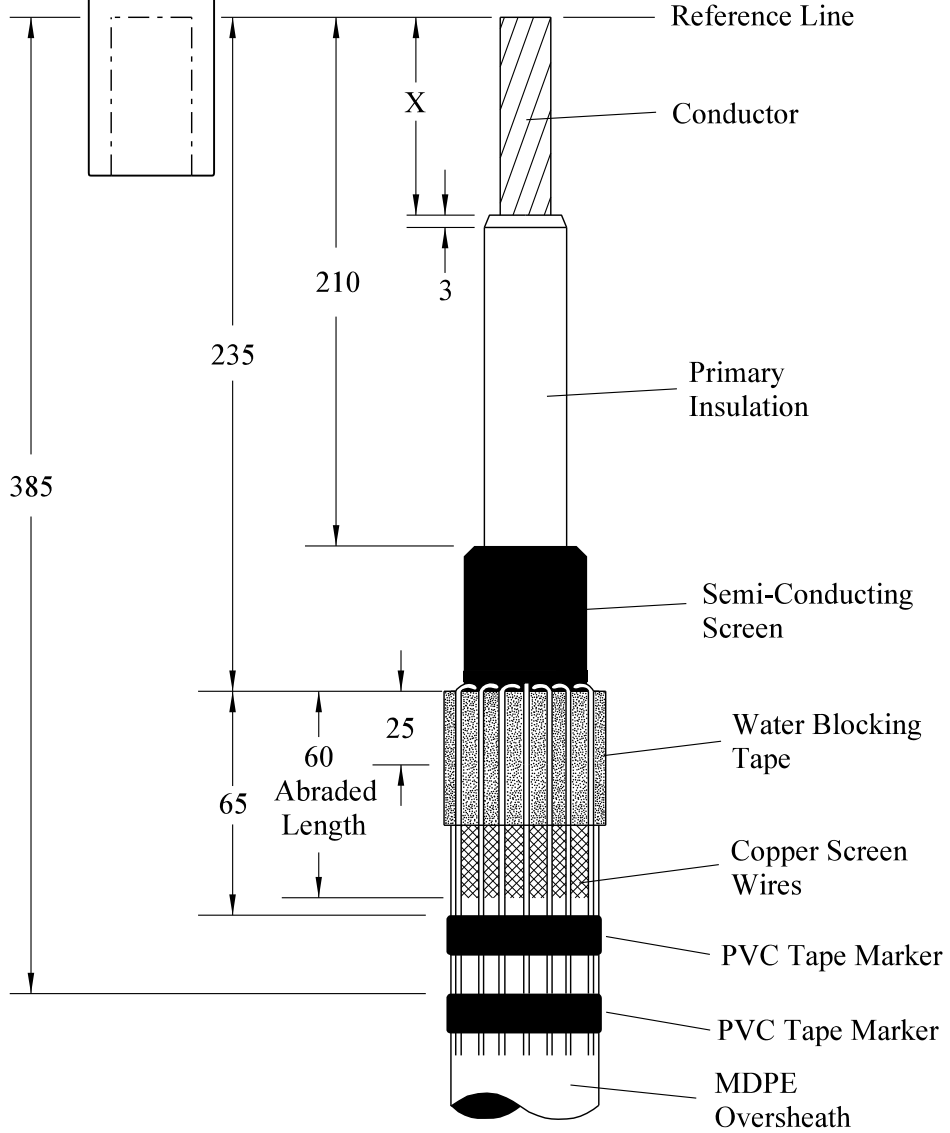



Fig 1

Rev No	Drawn	Chk'd	App'd	Date	Revision	
ORIGINAL ISSUE	DATE	WESTERN POWER DISTRIBUTION Design Department. Avonbank, Feeder Road, Bristol BS2 0TB Tel: 0117 933 2000 Fax: 0117 933 2001.				
Drawn	RJB	03/17	Title 300/400/630/800mm ² EPR SINGLE CORE M440TBG TEE CONNECTOR TERMINATION STRIPPING DIMENSIONS			
Checked					JP3D 7.406.1	
Approved						
SCALE	N.T.S.					

ALL RIGHTS ARE RESERVED TO WPD (South West) plc. NO PART OF THIS DRAWING MAY BE REPRODUCED OR TRANSMITTED IN ANY FORM OR BY ANY MEANS, INCLUDING PHOTOCOPYING AND RECORDING, OR STORED IN A RETRIEVAL SYSTEM OF ANY NATURE, WITHOUT PERMISSION.

All Dimensions in mm

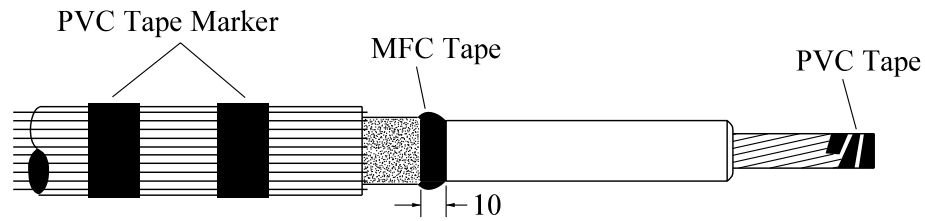

Fig 2

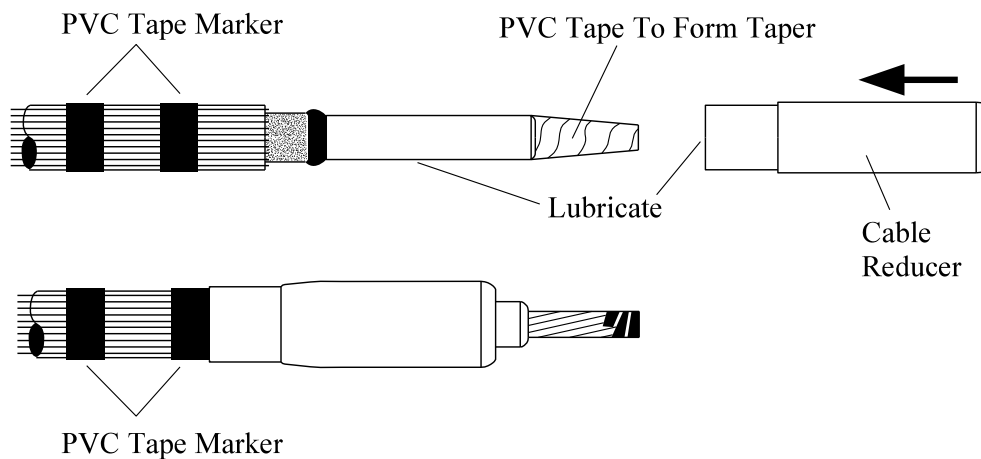



Fig 3

Rev No	Drawn	Chk'd	App'd	Date	Revision					
ORIGINAL ISSUE	DATE	WESTERN POWER DISTRIBUTION Design Department. Avonbank, Feeder Road, Bristol BS2 0TB Tel: 0117 933 2000 Fax: 0117 933 2001.								
Drawn	RJB						03/17	Title 300/400/630/800mm ² EPR SINGLE CORE M440TBG TEE CONNECTOR TERMINATION STRIPPING DIMENSIONS	Drg. No. JP3D 7.406.2	Rev No
Checked										
Approved										
SCALE	N.T.S.									

ALL RIGHTS ARE RESERVED TO WPD (South West) plc. NO PART OF THIS DRAWING MAY BE REPRODUCED OR TRANSMITTED IN ANY FORM OR BY ANY MEANS, INCLUDING PHOTOCOPYING AND RECORDING, OR STORED IN A RETRIEVAL SYSTEM OF ANY NATURE, WITHOUT PERMISSION.

All Dimensions in mm

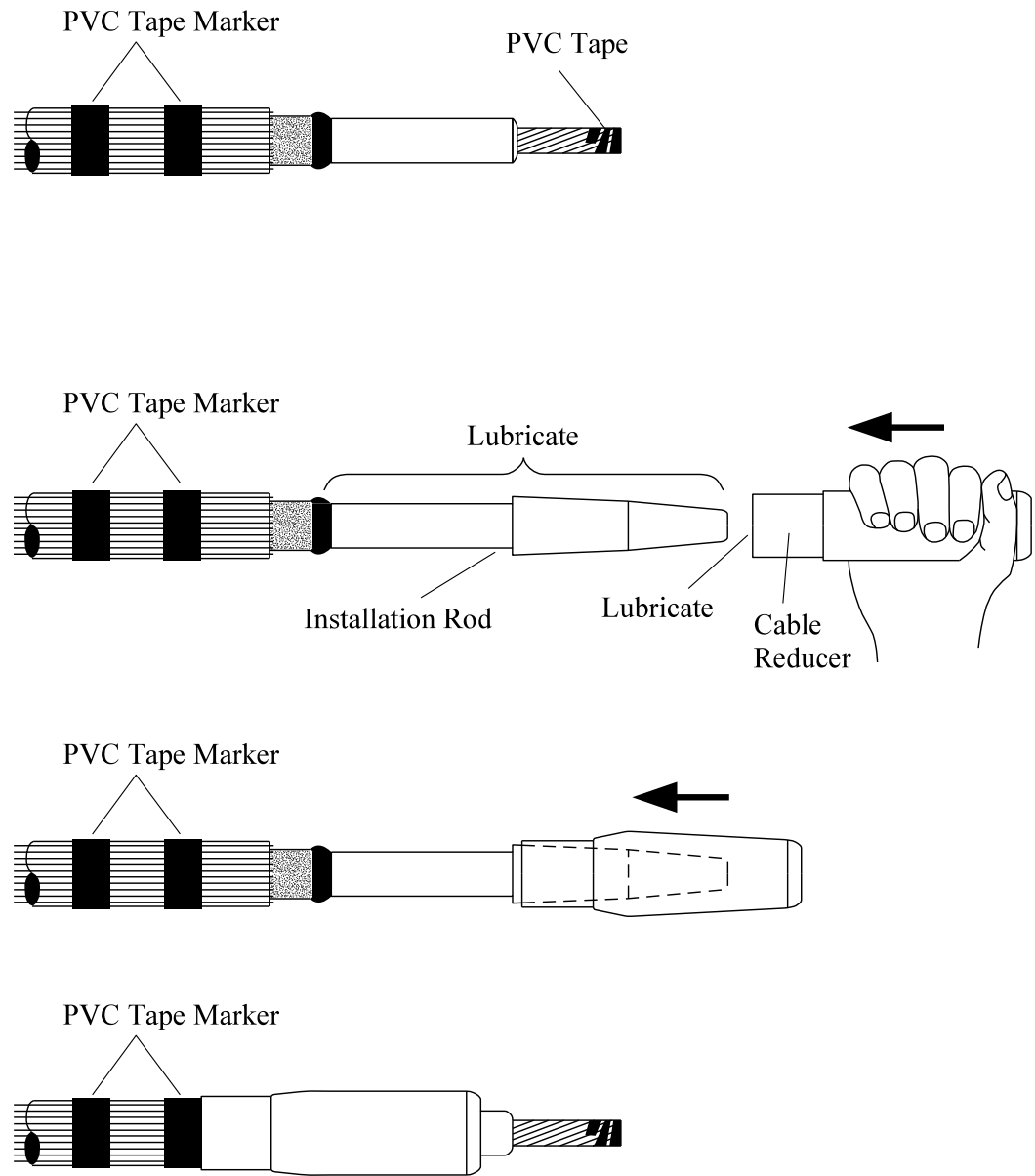



Fig 4

Rev No	Drawn	Chk'd	App'd	Date	Revision	
ORIGINAL ISSUE	DATE	WESTERN POWER DISTRIBUTION Design Department. Avonbank, Feeder Road, Bristol BS2 0TB Tel: 0117 933 2000 Fax: 0117 933 2001.				
Drawn	RJB	03/17	Title 300/400/630/800mm ² EPR SINGLE CORE M440TBG TEE CONNECTOR TERMINATION TERMINATION COMPLETION			
Checked					JP3D 7.406.3	
Approved						
SCALE	N.T.S.					

ALL RIGHTS ARE RESERVED TO WPD (South West) plc. NO PART OF THIS DRAWING MAY BE REPRODUCED OR TRANSMITTED IN ANY FORM OR BY ANY MEANS, INCLUDING PHOTOCOPYING AND RECORDING, OR STORED IN A RETRIEVAL SYSTEM OF ANY NATURE, WITHOUT PERMISSION.

All Dimensions in mm

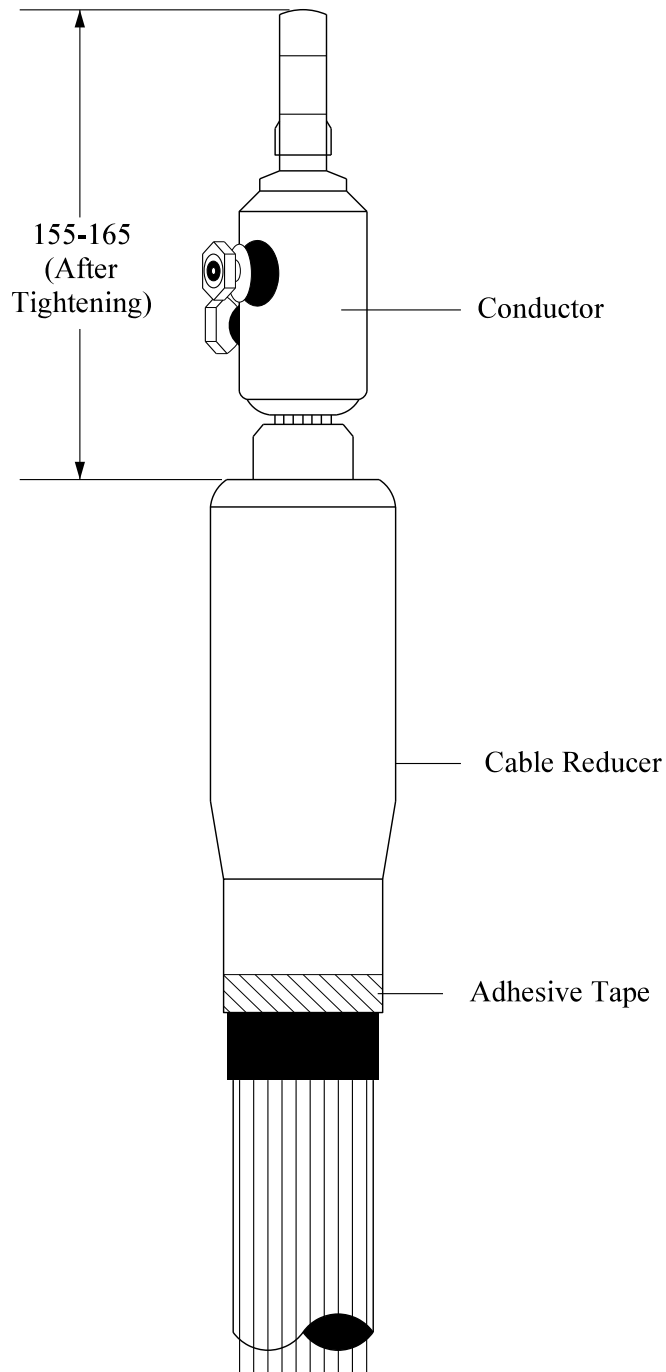



Fig 5

Rev No	Drawn	Chk'd	App'd	Date	Revision		
ORIGINAL	ISSUE	DATE	WESTERN POWER DISTRIBUTION Design Department. Avonbank, Feeder Road, Bristol BS2 0TB Tel: 0117 933 2000 Fax: 0117 933 2001.				
Drawn	RJB	03/17					
Checked							
Approved							
SCALE	N.T.S.		Title 300/400/630/800mm ² EPR SINGLE CORE M440TBG TEE CONNECTOR TERMINATION TERMINATION COMPLETION			Drg. No. JP3D 7.406.4	Rev No

ALL RIGHTS ARE RESERVED TO WPD (South West) plc. NO PART OF THIS DRAWING MAY BE REPRODUCED OR TRANSMITTED IN ANY FORM OR BY ANY MEANS, INCLUDING PHOTOCOPYING AND RECORDING, OR STORED IN A RETRIEVAL SYSTEM OF ANY NATURE, WITHOUT PERMISSION.

All Dimensions in mm

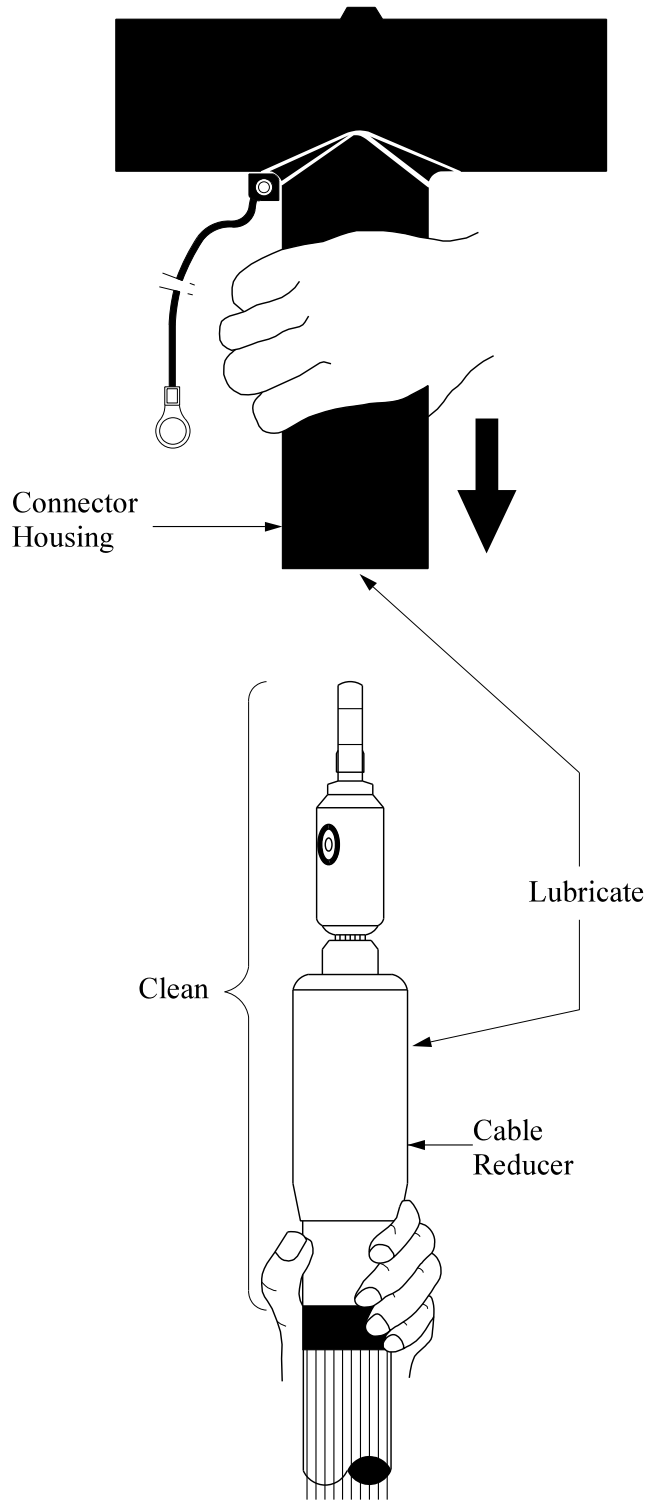

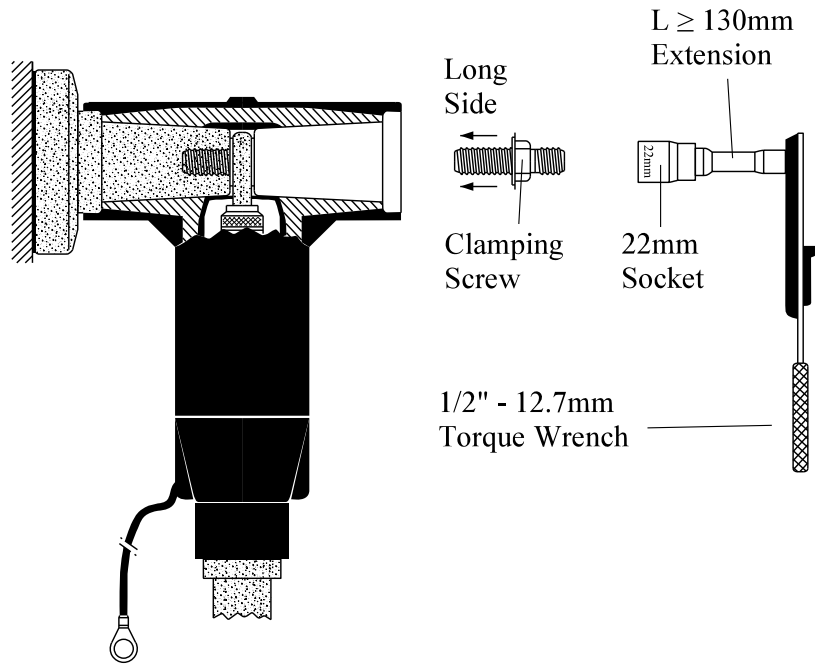
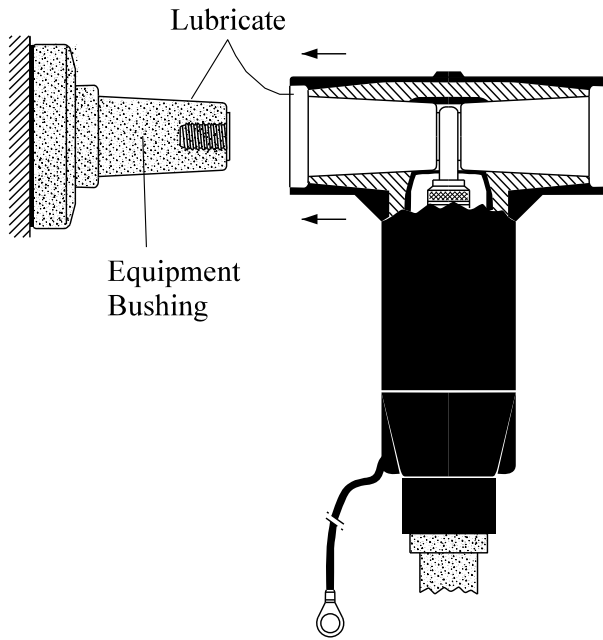



Fig 6

Rev No	Drawn	Chk'd	App'd	Date	Revision	
ORIGINAL ISSUE	DATE	WESTERN POWER DISTRIBUTION Design Department. Avonbank, Feeder Road, Bristol BS2 0TB Tel: 0117 933 2000 Fax: 0117 933 2001.				
Drawn	RJB	03/17	Title 300/400/630/800mm ² EPR SINGLE CORE M440TBG TEE CONNECTOR TERMINATION TERMINATION COMPLETION			
Checked					JP3D 7.406.5	
Approved						
SCALE	N.T.S.					

ALL RIGHTS ARE RESERVED TO WPD (South West) plc. NO PART OF THIS DRAWING MAY BE REPRODUCED OR TRANSMITTED IN ANY FORM OR BY ANY MEANS, INCLUDING PHOTOCOPYING AND RECORDING, OR STORED IN A RETRIEVAL SYSTEM OF ANY NATURE, WITHOUT PERMISSION.

All dimensions in mm



Rev No	Drawn	Chk'd	App'd	Date	Revision	
ORIGINAL ISSUE	DATE	WESTERN POWER DISTRIBUTION Design Department. Avonbank, Feeder Road, Bristol BS2 0TB Tel: 0117 933 2000 Fax: 0117 933 2001.				
Drawn	RJB	03/17	Title 300/400/630/800mm ² EPR SINGLE CORE M440TBG TEE CONNECTOR TERMINATION TERMINATION COMPLETION			
Checked					JP3D 7.406.6	
Approved						
SCALE	N.T.S.					

ALL RIGHTS ARE RESERVED TO WPD (South West) plc. NO PART OF THIS DRAWING MAY BE REPRODUCED OR TRANSMITTED IN ANY FORM OR BY ANY MEANS, INCLUDING PHOTOCOPYING AND RECORDING, OR STORED IN A RETRIEVAL SYSTEM OF ANY NATURE, WITHOUT PERMISSION.

All dimensions in mm

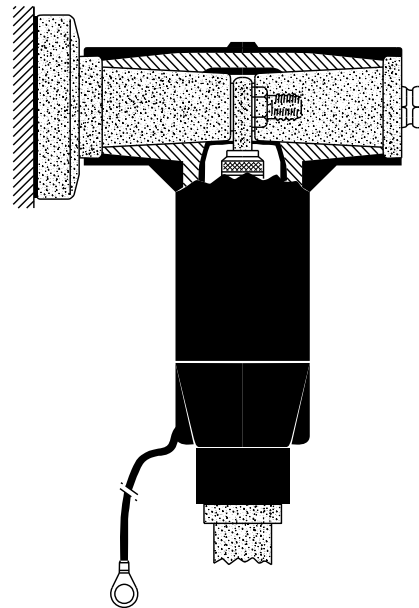
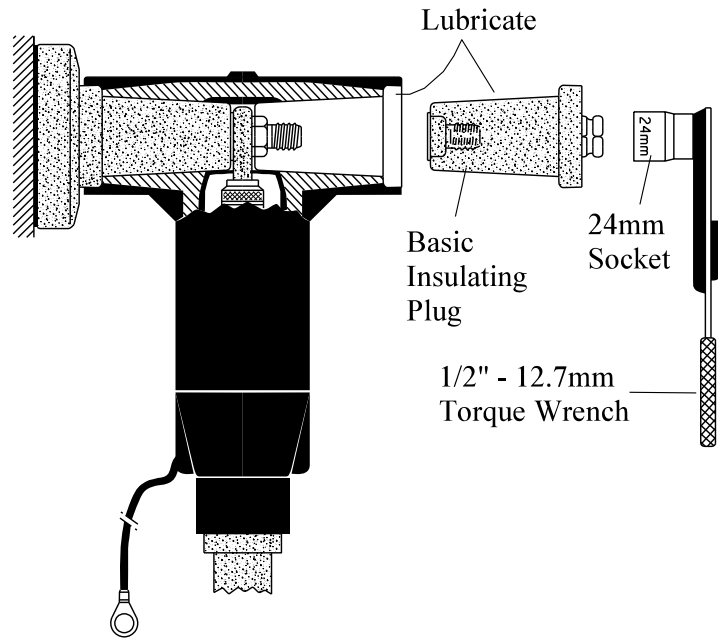

Rev No	Drawn	Chk'd	App'd	Date	Revision	
ORIGINAL ISSUE	DATE	WESTERN POWER DISTRIBUTION Design Department. Avonbank, Feeder Road, Bristol BS2 0TB Tel: 0117 933 2000 Fax: 0117 933 2001.				
Drawn	RJB	03/17	Title 300/400/630/800mm ² EPR SINGLE CORE M440TBG TEE CONNECTOR TERMINATION TERMINATION COMPLETION			
Checked					JP3D 7.406.7	
Approved						
SCALE	N.T.S.					

ALL RIGHTS ARE RESERVED TO WPD (South West) plc. NO PART OF THIS DRAWING MAY BE REPRODUCED OR TRANSMITTED IN ANY FORM OR BY ANY MEANS, INCLUDING PHOTOCOPYING AND RECORDING, OR STORED IN A RETRIEVAL SYSTEM OF ANY NATURE, WITHOUT PERMISSION.

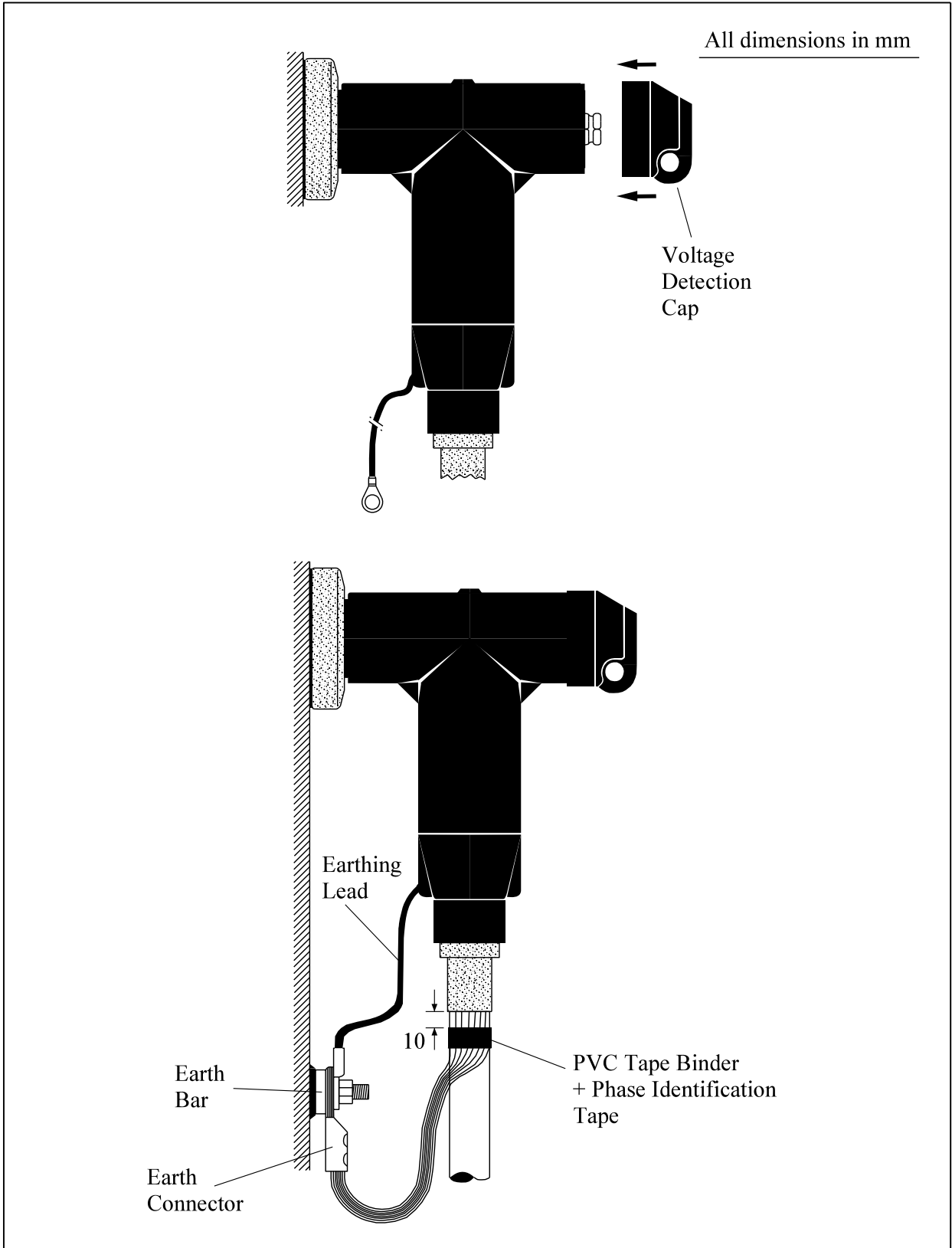

Rev No	Drawn	Chk'd	App'd	Date	Revision
ORIGINAL ISSUE	DATE	WESTERN POWER DISTRIBUTION Design Department. Avonbank, Feeder Road, Bristol BS2 0TB Tel: 0117 933 2000 Fax: 0117 933 2001.			 WESTERN POWER DISTRIBUTION
Drawn	RJB	03/17	Title 300/400/630/800mm ² EPR SINGLE CORE M440TBG TEE CONNECTOR TERMINATION TERMINATION COMPLETION		
Checked			Drg. No.		Rev No
Approved			JP3D 7.406.8		
SCALE	N.T.S.				

ALL RIGHTS ARE RESERVED TO WPD (South West) plc. NO PART OF THIS DRAWING MAY BE REPRODUCED OR TRANSMITTED IN ANY FORM OR BY ANY MEANS, INCLUDING PHOTOCOPYING AND RECORDING, OR STORED IN A RETRIEVAL SYSTEM OF ANY NATURE, WITHOUT PERMISSION.

ST: CA3V/4 PROCEDURES FOR MAKING 33kV CABLE TERMINATIONS

JOINTING PROCEDURE 7.407

300/400/630 and 800mm², COPPER WIRE SCREEN, 33kV EUROMOLD (M) 440 TB/G INTERFACE C, 1250A, in BACK to BACK CONFIGURATION SEPARABLE CONNECTOR TERMINATIONS.

This procedure is to be read in conjunction with the appropriate General Requirements ST: CA3C/3 Section 6 of the 33kV Jointing Manual

JOINTING PROCEDURE 7.407

TERMINATION KIT MATERIALS LIST

CABLE SIZES — 300mm² CWS

Item	Quantity
(M)440TB/G-32-120.300-14.5MWS Separable Connector 1250A (each)	6
(M)400CP-Connector Plug	3
Connector BET 120-12 or BET 35-12	6
Cable cleat AR2-A13-TB	6

CABLE SIZES — 400mm² CWS

Item	Quantity
(M)440TB/G-37-TBMC-400.630-12.5MWS Separable Connector 1250A (each)	6
(M)400CP-Connector Plug	3
Connector BET 120-12 or BET 35-12	6
Cable cleat AR2-A13-TB	6

CABLE SIZES — 630mm² CWS

Item	Quantity
(M)440TB/G-44-TBMC-400.630-12.5.MWS Separable Connector 1250A (each)	6
(M)400CP-Connector Plug	3
Connector BET 120-12 or BET 35-12	6
Cable cleat AR2-A14-TB	6

CABLE SIZES — 800mm² CWS

Item	Quantity
(M)440TB/G-44-TBMC-400.800-12.5.MWS Separable Connector 1250A (each)	6
(M)400CP-Connector Plug	3
Connector BET 120-12 or BET 35-12	6
Cable cleat AR2-A14-TB	6

Note: - The 800mm² (M) 440 TB/G uses a compression lug therefore ensure you have the correct compression tool and dies sets before commencing work.

ADDITIONAL ITEMS FOR EACH TERMINATION

PVC tape
Scotch 70
Scotch 13 tape
Tinned copper wire 16 swg
Tinned copper wire 20 swg
De-Solvit 1000 FD
De-Solvit 1000
Workhorse dry wipes
Emery cloth
5313 Water block tape
Cable ties
Sealing putty
Aluminium oxide cloth 320 grit
Aluminium oxide cloth 400 grit
Copaslip

Note: - Individual material item numbers (E 5) are to be found in Section 4 of the 33kV Jointing Manual.

JOINTING PROCEDURE 7.407

Actions	General Requirement (ST: CA3C/3)
Refer to Drawings JP3D 7.407.1, 7.407.2, 7.407.3 7.407.4, 7.407.5, 7.407.6, 7.407.7, 7.407.8, 7.407.9, 7.407.10, 7.407.11, 7.407.12 and 7.407.13 whilst undertaking this Jointing Procedure.	
1. Identify and mark core phasing clear of termination position.	--
2. Set and align cables into their termination positions.	--
3. Clean each oversheath for a distance of 1 .5m.	--
4. Apply a temporary earth continuity bond clear of termination position.	11
5. Park a mastic lined heat shrink tube next to temporary earth. continuity bond of each core.	--
6. Park a compression gland over each core.	54
7. Set and mark cables into their required positions.	5/6
8. Cut each cable 300mm above its connection point.	--
9. Place a connector on each bushing, measure and mark internal depth of barrel onto outside of connector.	--
This mark becomes the reference point for the procedure.	
10. Remove oversheaths and bedding tapes — Fig 1.	17
11. Abrade oversheaths — Fig 1.	18
12. Apply a turn of mastic around oversheath — Fig 1.	--
13. Straighten copper screen wires and bend back over oversheath termination ensure copper screen wires are spaced evenly and bedded into mastic applied in 11.	--
14. Apply three turns of 20swg binder over copper wires at a point 275mm down from the reference point.	--
15. Place a PVC tape marker 245mm from the reference point onto the copper screen wires — Fig 1.	--
16. Offer cores to reference point marked on connectors, mark and cut cores.	--

JOINTING PROCEDURE 7.407 - Continued

Actions	General Requirement (ST: CA3C/3)
17. Remove semi-conducting screens, ensuring insulation is free from all conductive material — Fig 1.	25
18. Remove core insulation making a 3mm bevel to insulation end — Fig 1.	27
19. Apply a few turns of PVC tape to the conductor end as a protection.	--
20. Thoroughly clean core insulation.	--
21. Apply field control mastic strip, type MFC, slightly stretch one end applying with a 5mm overlap onto both semi-conducting screen and core insulation, push the mastic in place while stretching it progressively until both ends overlap and tear-off excess mastic — Fig 2	--
Note: - Ensure mastic does not break during application.	
22. Lubricate internal face (stepped end) of the cable reducer, slide cable reducer down the core without hesitation and in one smooth movement until the end reaches the PVC tape marker applied in 9—Fig 4.	--
23. Remove connectors from bushings and connect to phase conductors, ensure connector palm is in correct position to bushings before shearing- Fig 5.	33
24. Remove any burrs resulting from tightening.	--
25. Clean cable reducer, core insulation and connector — Fig 6.	--
26. Lightly lubricate the inner surface of the tee connector housing and cable reducer — Fig 6.	--
27. Check the angle of the tee connector housing is correct to connector palm and longer interface is pointing towards the bushing. Whilst supporting the cable reducer at its stepped end preventing movement, gently slide the housing onto the cable until it cannot advance no further — Fig 6.	--
28. Check correct installation by trying to pull back the connector, it is correct when it stays in its locked position, also check to ensure cable reducer has stayed in place during installation — Fig 7.	--
29. Clean and lightly lubricate both inner face of connector housing and bushing, push connector housing onto bushing.	--
30. Insert clamping screw (longer thread) into threaded hole of bushing and tighten — Fig 8.	--

JOINTING PROCEDURE 7.407 - Continued

Actions	General Requirement (ST: CA3C/3)
Note: - The screw must be tighten with a torque wrench exerting a 50Nm of torque using a 22mm socket in order to achieve correct torque, ensure there is to be no lubricate on the threaded parts.	
31. Clean and lightly lubricate both, connector interface and connecting plug interface.	--
32. Push the connecting plug into the connector, engage the threads and hand tighten - Fig 8.	--
Note: - The plug must be tighten with a torque wrench exerting 50Nm of torque using a 10mm hex key in order to achieve correct torque, ensure there is to be no lubricate on the threaded parts.	
33. Clean and lightly lubricate both, the second connector and the connecting plug interface. Push the connector on to the connecting plug.	--
34. Insert the second 400TCS clamping screw (longer thread) into threaded hole of the connecting plug and tighten.	--
Note: - The screw must be tighten with a torque wrench exerting a 50Nm of torque using a 22mm socket in order to achieve correct torque, ensure there is to be no lubricate on the threaded parts.	
35. Clean and lightly lubricate both, connector interface and connecting plug interface.	--
36. Push the connecting plug into the connector, engage the threads and hand tighten.	--
Note: - The plug must be tighten with a torque wrench exerting 50Nm of torque using a 24mm socket in order to achieve correct torque, ensure there is to be no lubricate on the threaded parts.	
37. Clean inside of protective cap and outer face of the connector housing and insulating plug.	--
38. Push protective cap over connector housing onto the insulating plug, slightly pull the edge of the protective cap to exhaust any air whilst pressing cap centre onto its locking point until it snaps into place. Position the cap with the pulling tab facing downwards.	--

JOINTING PROCEDURE 7.407 - Continued

Actions	General Requirement (ST: CA3C/3)
39. Apply four turns of Scotch tape of the relevant phase colour around copper screen wires 10mm below cable reducer end.	--
Do not apply PVC tape to the cable reducer or connector housing.	
40. Form copper screen wires into a bunch and removing 20swg binder and PVC tape binder applied in 13/14.	--
41. Fit gland plate to cable box.	--
42. Fit compression glands to gland plate and each cable.	--
43. Form copper screen wire bunches into one conductor terminating into a earth connector, and connect to earth stud.	--
44. Remove temporary earth continuity bond applied in 4 and reseal oversheaths.	--
45. Replace cable box cover ensuring all external bolt threads are treated with "Copaslip" paste and security bolts are in place.	--
46. Ensure all cables are adequately cleated and carry the weight of the cables.	--

All Dimensions in mm

Note:- "X" = Depth Of Connector
Entry + 5

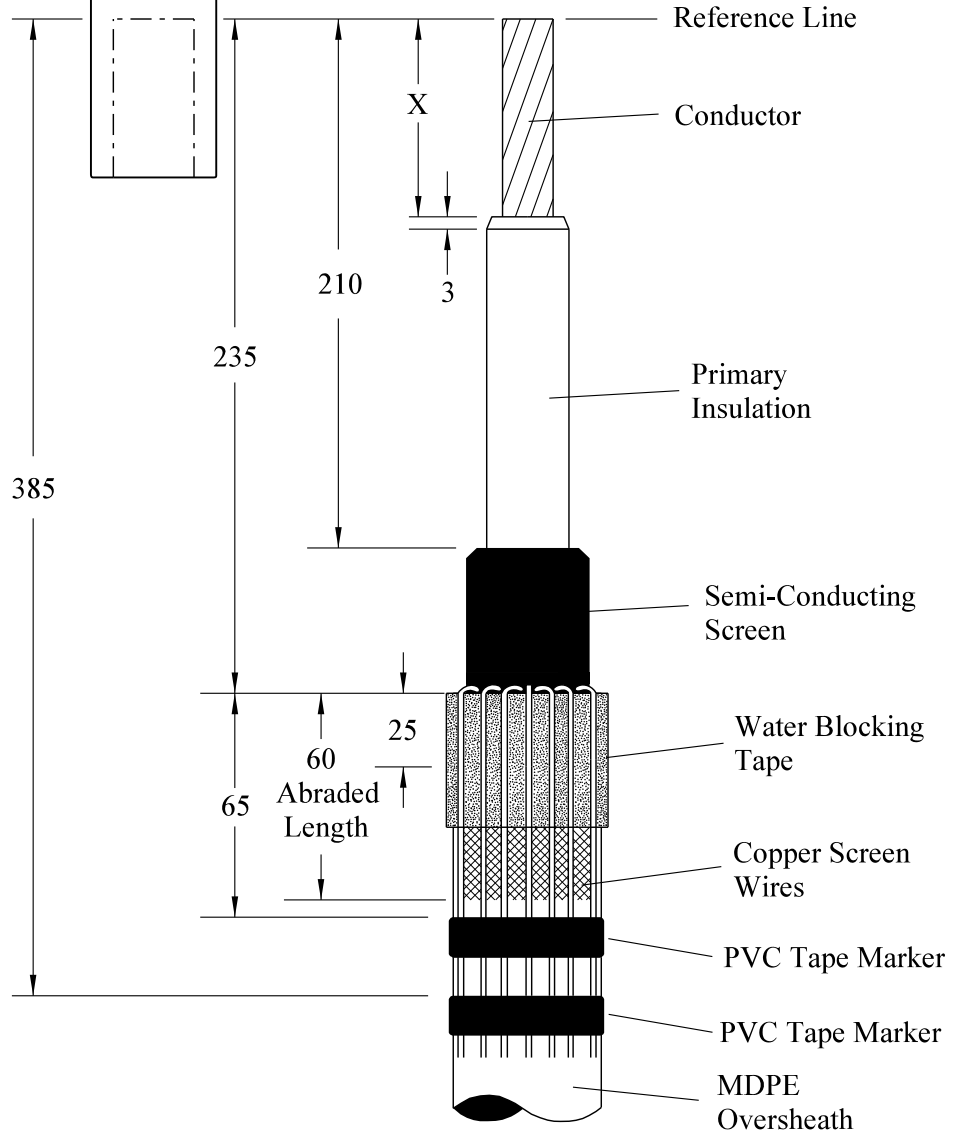



Fig 1

Rev No	Drawn	Chk'd	App'd	Date	Revision	
ORIGINAL ISSUE	DATE	WESTERN POWER DISTRIBUTION Design Department. Avonbank, Feeder Road, Bristol BS2 0TB Tel: 0117 933 2000 Fax: 0117 933 2001.				
Drawn	RJB	03/17	Title 300/400/630/800mm ² EPR SINGLE CORE M44OTBG TEE CONNECTOR TERMINATION STRIPPING DIMENSIONS			
Checked					JP3D 7.407.1	
Approved						
SCALE	N.T.S.					

ALL RIGHTS ARE RESERVED TO WPD (South West) plc. NO PART OF THIS DRAWING MAY BE REPRODUCED OR TRANSMITTED IN ANY FORM OR BY ANY MEANS, INCLUDING PHOTOCOPYING AND RECORDING, OR STORED IN A RETRIEVAL SYSTEM OF ANY NATURE, WITHOUT PERMISSION.

All Dimensions in mm

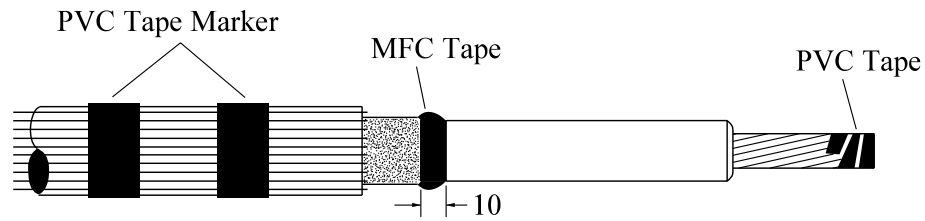

Fig 2

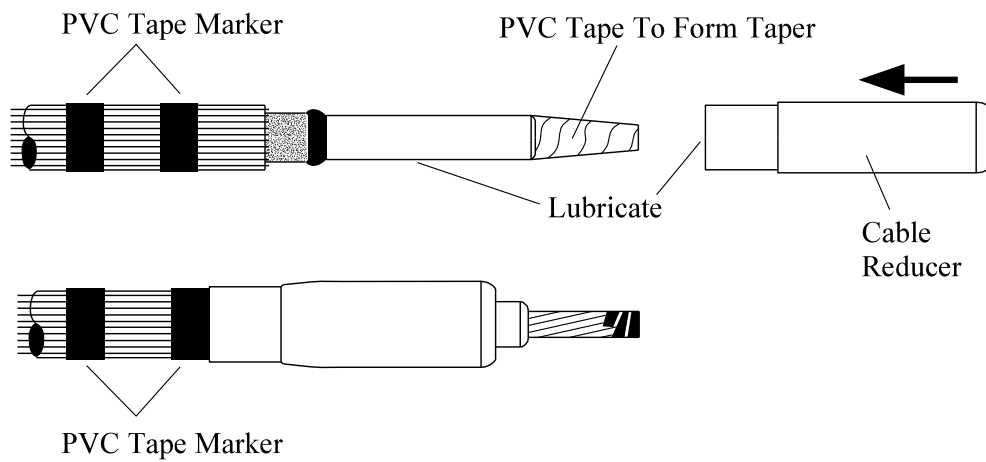



Fig 3

Rev No	Drawn	Chk'd	App'd	Date	Revision					
ORIGINAL ISSUE	DATE	WESTERN POWER DISTRIBUTION Design Department. Avonbank, Feeder Road, Bristol BS2 0TB Tel: 0117 933 2000 Fax: 0117 933 2001.								
Drawn	RJB						03/17	Title	Drg. No.	Rev No
Checked										
Approved										
SCALE	N.T.S.									

ALL RIGHTS ARE RESERVED TO WPD (South West) plc. NO PART OF THIS DRAWING MAY BE REPRODUCED OR TRANSMITTED IN ANY FORM OR BY ANY MEANS, INCLUDING PHOTOCOPYING AND RECORDING, OR STORED IN A RETRIEVAL SYSTEM OF ANY NATURE, WITHOUT PERMISSION.

All Dimensions in mm

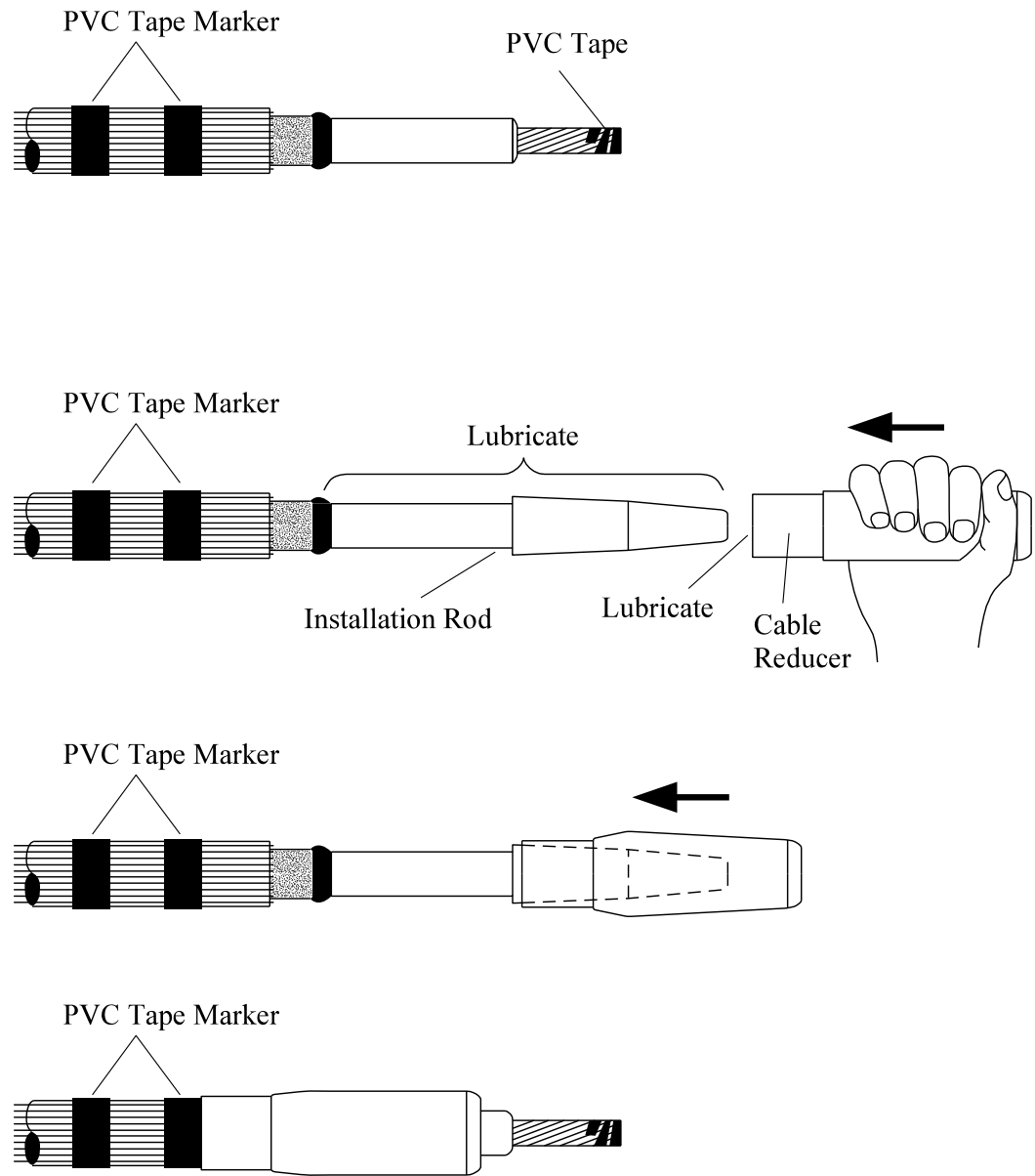



Fig 4

Rev No	Drawn	Chk'd	App'd	Date	Revision	
ORIGINAL ISSUE	DATE	WESTERN POWER DISTRIBUTION Design Department. Avonbank, Feeder Road, Bristol BS2 0TB Tel: 0117 933 2000 Fax: 0117 933 2001.				
Drawn	RJB	03/17	Title 300/400/630/800mm ² EPR SINGLE CORE M440TBG TEE CONNECTOR TERMINATION TERMINATION COMPLETION			
Checked					Drg. No.	Rev No
Approved					JP3D 7.407.3	
SCALE	N.T.S.					

ALL RIGHTS ARE RESERVED TO WPD (South West) plc. NO PART OF THIS DRAWING MAY BE REPRODUCED OR TRANSMITTED IN ANY FORM OR BY ANY MEANS, INCLUDING PHOTOCOPYING AND RECORDING, OR STORED IN A RETRIEVAL SYSTEM OF ANY NATURE, WITHOUT PERMISSION.

All Dimensions in mm

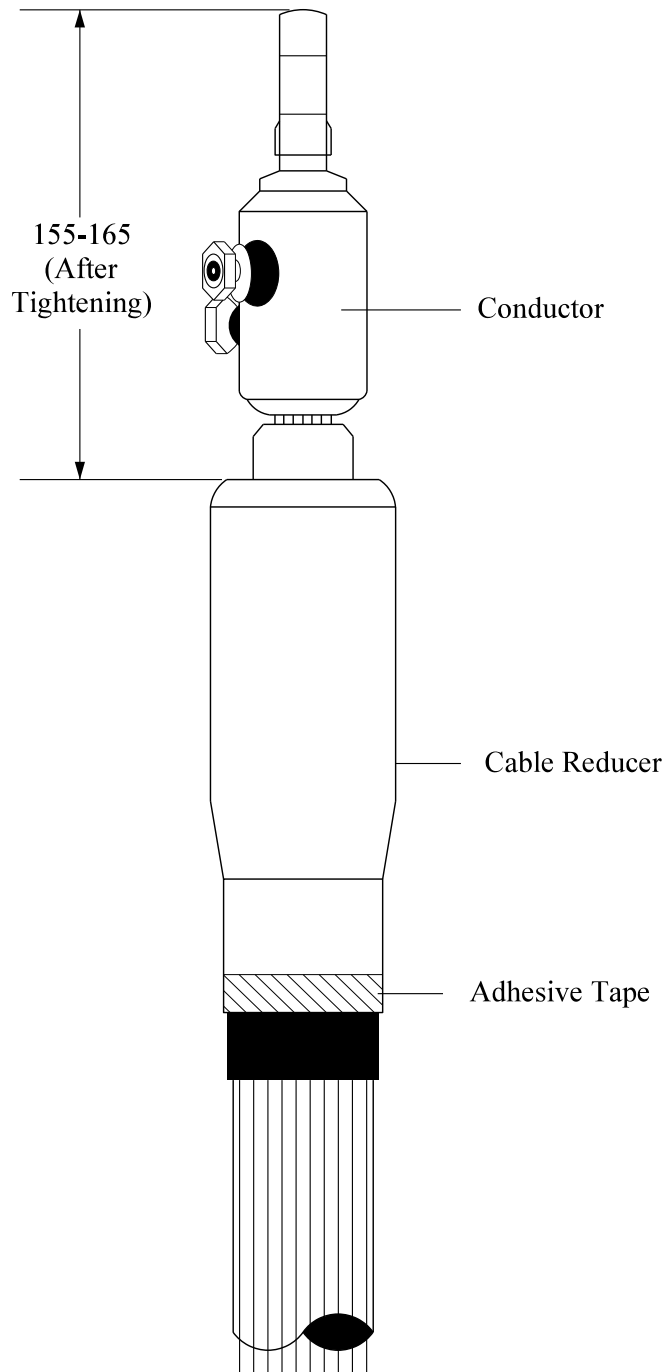



Fig 5

Rev No	Drawn	Chk'd	App'd	Date	Revision	
ORIGINAL	ISSUE	DATE	WESTERN POWER DISTRIBUTION Design Department. Avonbank, Feeder Road, Bristol BS2 0TB Tel: 0117 933 2000 Fax: 0117 933 2001.			
Drawn	RJB	03/17	Title 300/400/630/800mm ² EPR SINGLE CORE M440TBG TEE CONNECTOR TERMINATION TERMINATION COMPLETION			
Checked			Drg. No.			Rev No
Approved			JP3D 7.407.4			
SCALE	N.T.S.					

ALL RIGHTS ARE RESERVED TO WPD (South West) plc. NO PART OF THIS DRAWING MAY BE REPRODUCED OR TRANSMITTED IN ANY FORM OR BY ANY MEANS, INCLUDING PHOTOCOPYING AND RECORDING, OR STORED IN A RETRIEVAL SYSTEM OF ANY NATURE, WITHOUT PERMISSION.

All Dimensions in mm

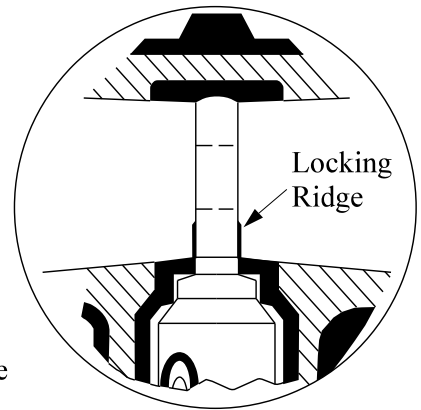
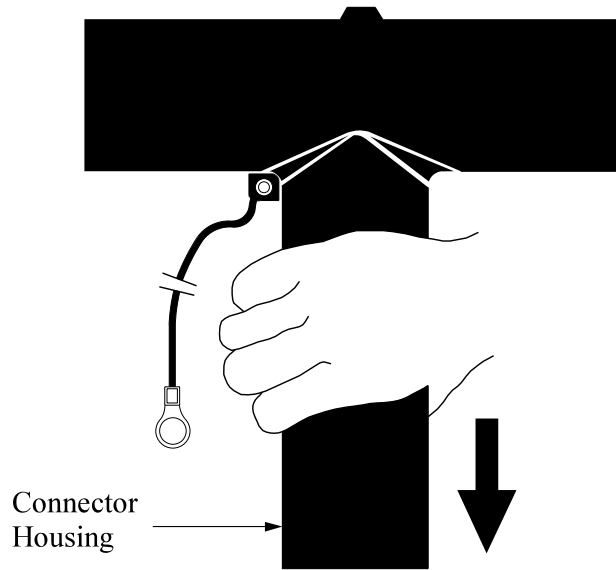

Fig 7

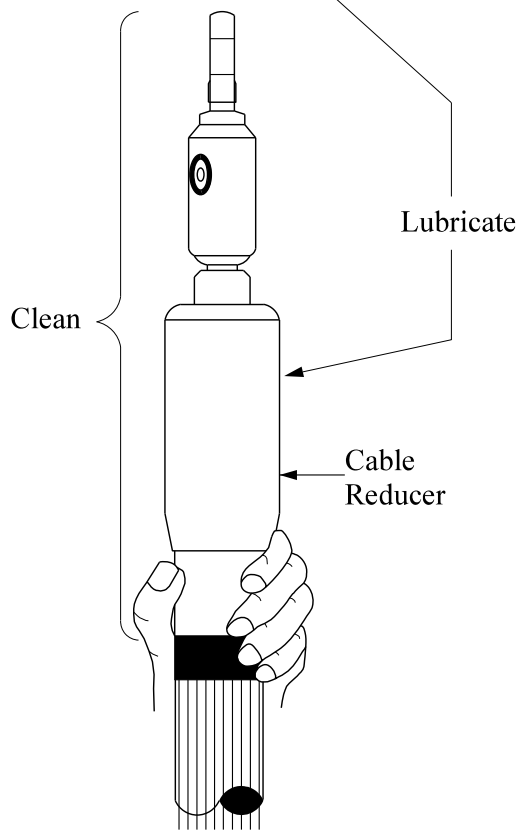

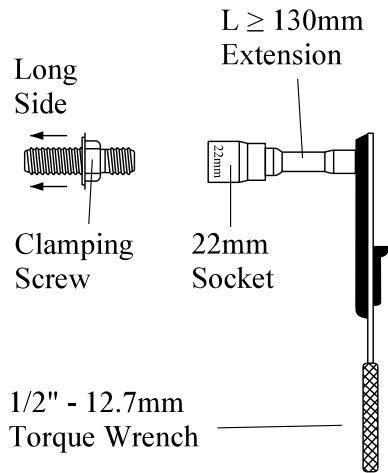
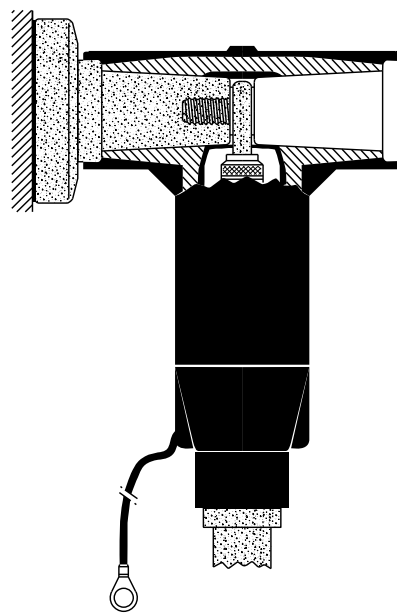
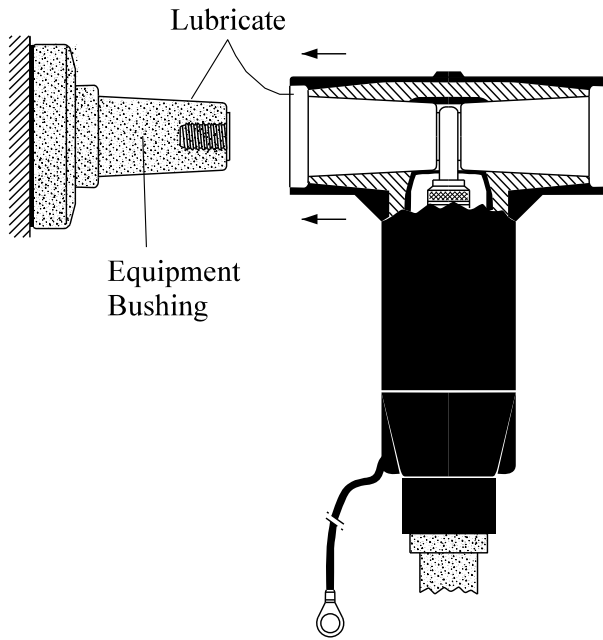



Fig 6

Rev No	Drawn	Chk'd	App'd	Date	Revision	
ORIGINAL ISSUE	DATE	WESTERN POWER DISTRIBUTION Design Department. Avonbank, Feeder Road, Bristol BS2 0TB Tel: 0117 933 2000 Fax: 0117 933 2001.				
Drawn	RJB 03/17	Title				
Checked		M440TBG TEE CONNECTOR TERMINATION TERMINATION COMPLETION			JP3D 7.407.5	
Approved		SCALE			N.T.S.	

ALL RIGHTS ARE RESERVED TO WPD (South West) plc. NO PART OF THIS DRAWING MAY BE REPRODUCED OR TRANSMITTED IN ANY FORM OR BY ANY MEANS, INCLUDING PHOTOCOPYING AND RECORDING, OR STORED IN A RETRIEVAL SYSTEM OF ANY NATURE, WITHOUT PERMISSION.

All dimensions in mm



Rev No	Drawn	Chk'd	App'd	Date	Revision		
ORIGINAL ISSUE	DATE	WESTERN POWER DISTRIBUTION Design Department. Avonbank, Feeder Road, Bristol BS2 0TB Tel: 0117 933 2000 Fax: 0117 933 2001.					
Drawn	RJB	03/17	Title				Drg. No.
Checked			M440TBG (P2) TEE CONNECTOR TERMINATION BACK TO BACK			JP3D 7.407.6	
Approved			SCALE				N.T.S.

ALL RIGHTS ARE RESERVED TO WPD (South West) plc. NO PART OF THIS DRAWING MAY BE REPRODUCED OR TRANSMITTED IN ANY FORM OR BY ANY MEANS, INCLUDING PHOTOCOPYING AND RECORDING, OR STORED IN A RETRIEVAL SYSTEM OF ANY NATURE, WITHOUT PERMISSION.

All dimensions in mm

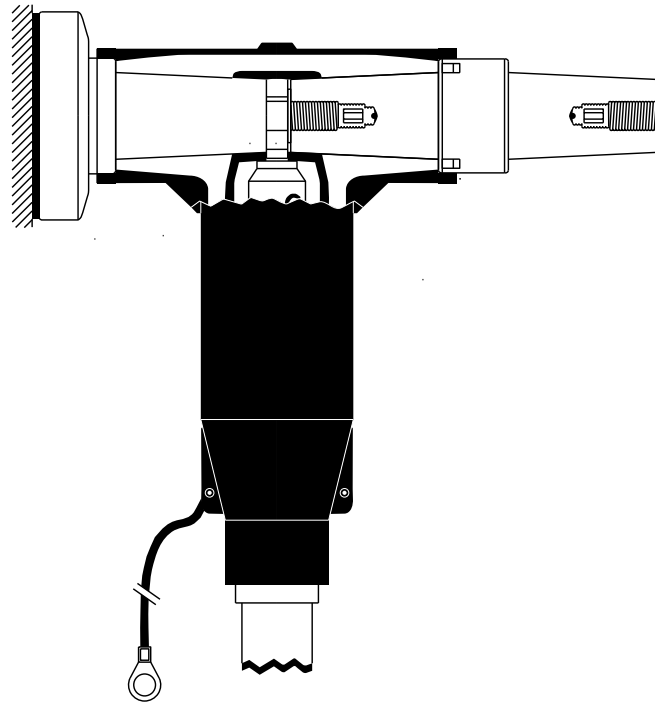
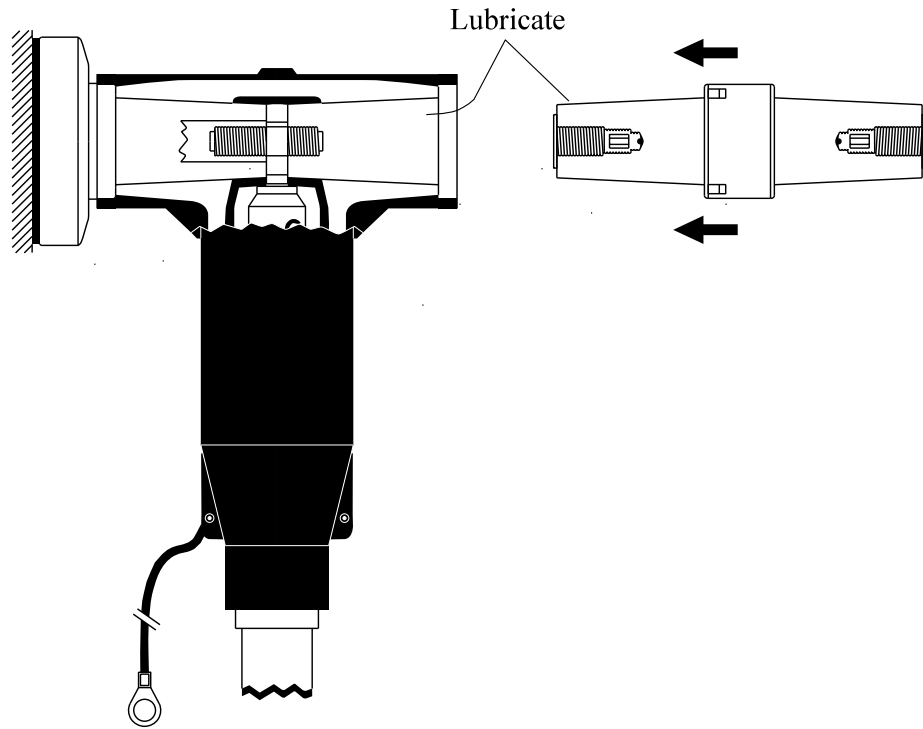

Rev No	Drawn	Chk'd	App'd	Date	Revision	
ORIGINAL ISSUE	DATE	WESTERN POWER DISTRIBUTION Design Department. Avonbank, Feeder Road, Bristol BS2 0TB Tel: 0117 933 2000 Fax: 0117 933 2001.				
Drawn	RJB	03/17	Title			
Checked			M440TBG (P2) TEE CONNECTOR BACK TO BACK		JP3D 7.407.7	
Approved						
SCALE	N.T.S.					

ALL RIGHTS ARE RESERVED TO WPD (South West) plc. NO PART OF THIS DRAWING MAY BE REPRODUCED OR TRANSMITTED IN ANY FORM OR BY ANY MEANS, INCLUDING PHOTOCOPYING AND RECORDING, OR STORED IN A RETRIEVAL SYSTEM OF ANY NATURE, WITHOUT PERMISSION.

All dimensions in mm

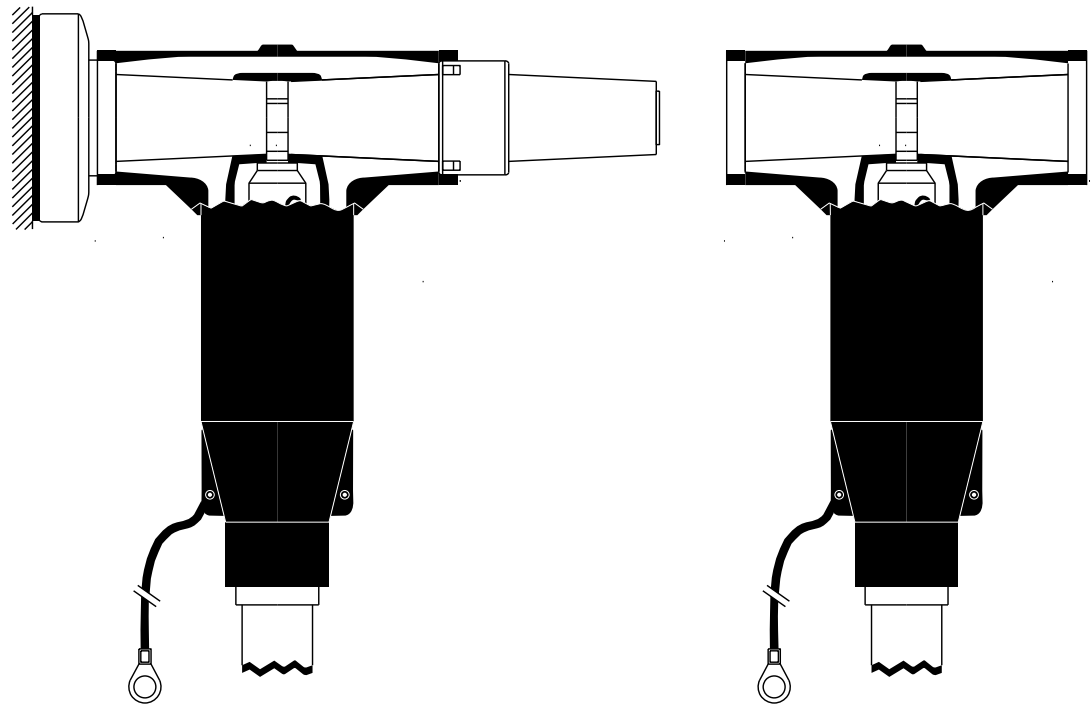
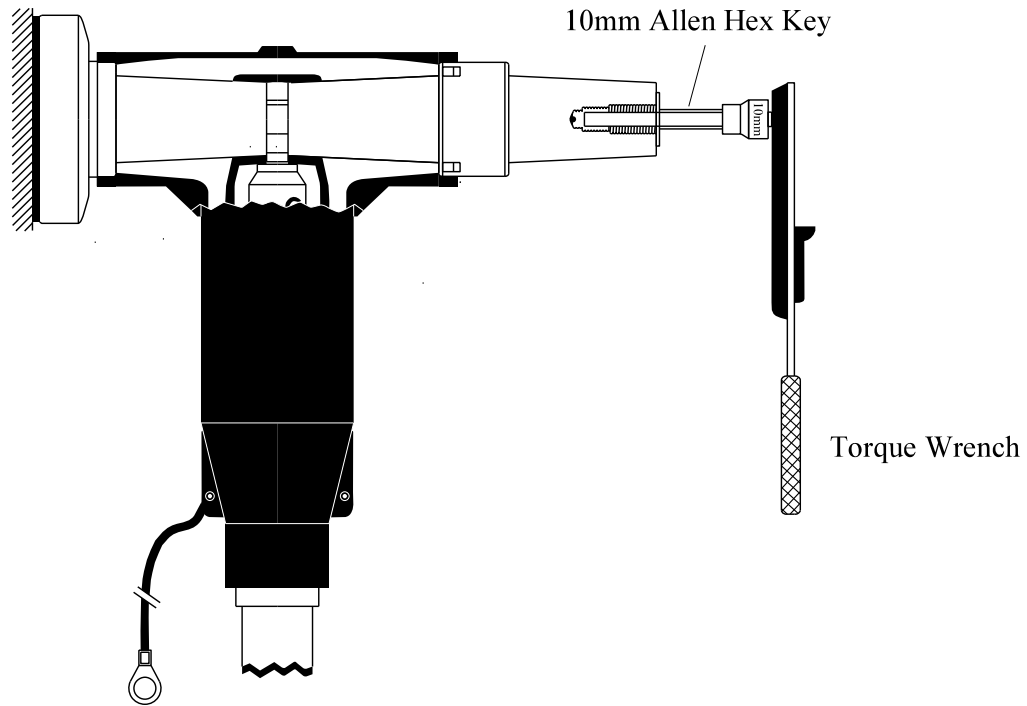

Rev No	Drawn	Chk'd	App'd	Date	Revision					
ORIGINAL ISSUE	DATE	WESTERN POWER DISTRIBUTION Design Department. Avonbank, Feeder Road, Bristol BS2 0TB Tel: 0117 933 2000 Fax: 0117 933 2001.								
Drawn	RJB						03/17	Title	Drg. No.	Rev No
Checked								M440TBG (P2) TEE CONNECTOR	JP3D 7.407.8	
Approved								BACK TO BACK		
SCALE	N.T.S.									

ALL RIGHTS ARE RESERVED TO WPD (South West) plc. NO PART OF THIS DRAWING MAY BE REPRODUCED OR TRANSMITTED IN ANY FORM OR BY ANY MEANS, INCLUDING PHOTOCOPYING AND RECORDING, OR STORED IN A RETRIEVAL SYSTEM OF ANY NATURE, WITHOUT PERMISSION.

All dimensions in mm

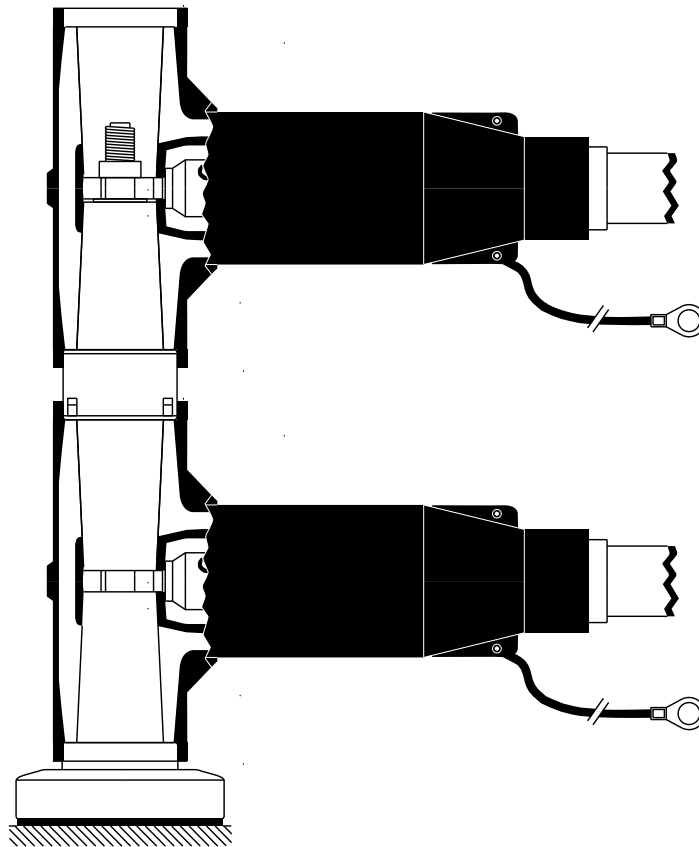

Rev No	Drawn	Chk'd	App'd	Date	Revision	
ORIGINAL ISSUE	DATE	WESTERN POWER DISTRIBUTION Design Department. Avonbank, Feeder Road, Bristol BS2 0TB Tel: 0117 933 2000 Fax: 0117 933 2001.				
Drawn	RJB	03/17	Title			
Checked			M440TBG (P2) TEE CONNECTOR BACK TO BACK			Drg. No.
Approved						Rev No
SCALE	N.T.S.					JP3D 7.407.9

ALL RIGHTS ARE RESERVED TO WPD (South West) plc. NO PART OF THIS DRAWING MAY BE REPRODUCED OR TRANSMITTED IN ANY FORM OR BY ANY MEANS, INCLUDING PHOTOCOPYING AND RECORDING, OR STORED IN A RETRIEVAL SYSTEM OF ANY NATURE, WITHOUT PERMISSION.

All dimensions in mm

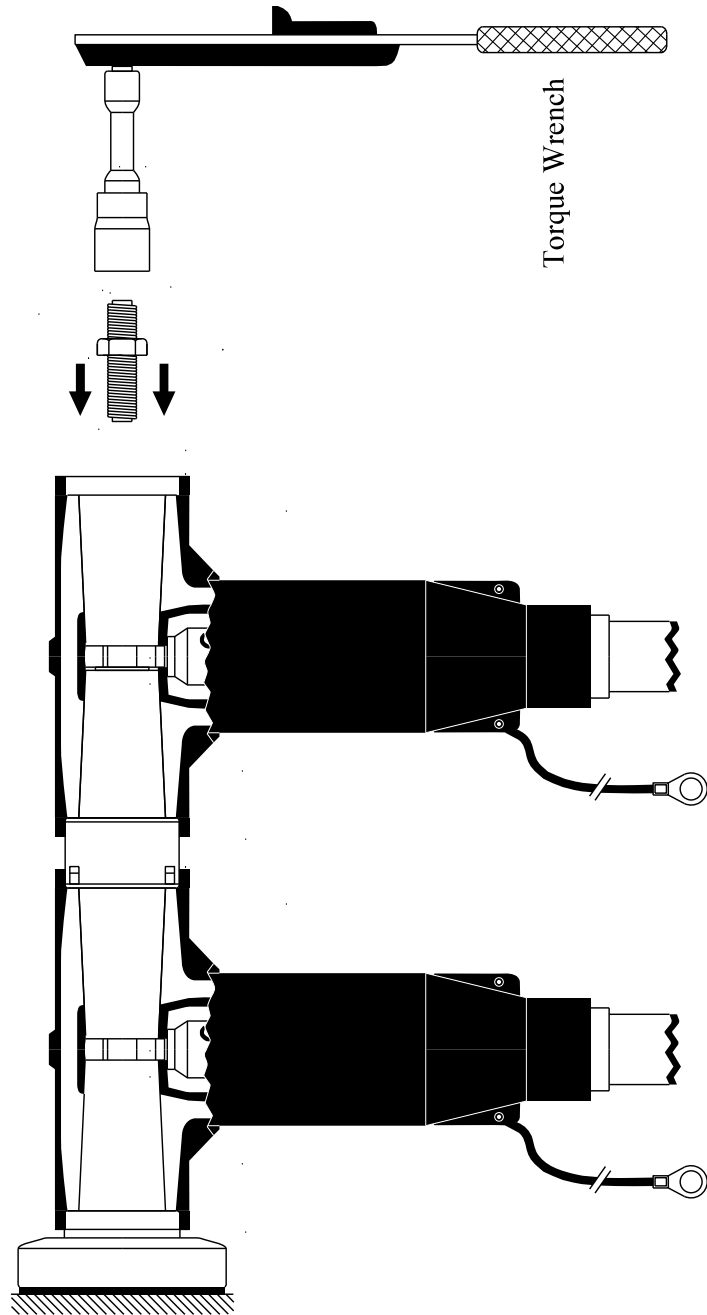

Rev No	Drawn	Chk'd	App'd	Date	Revision	
ORIGINAL ISSUE	DATE	WESTERN POWER DISTRIBUTION Design Department. Avonbank, Feeder Road, Bristol BS2 0TB Tel: 0117 933 2000 Fax: 0117 933 2001.				
Drawn	RJB	03/17	Title			
Checked			M440TBG (P2) TEE CONNECTOR BACK TO BACK		Drg. No.	Rev No
Approved					JP3D 7.407.10	
SCALE	N.T.S.					

ALL RIGHTS ARE RESERVED TO WPD (South West) plc. NO PART OF THIS DRAWING MAY BE REPRODUCED OR TRANSMITTED IN ANY FORM OR BY ANY MEANS, INCLUDING PHOTOCOPYING AND RECORDING, OR STORED IN A RETRIEVAL SYSTEM OF ANY NATURE, WITHOUT PERMISSION.

All dimensions in mm

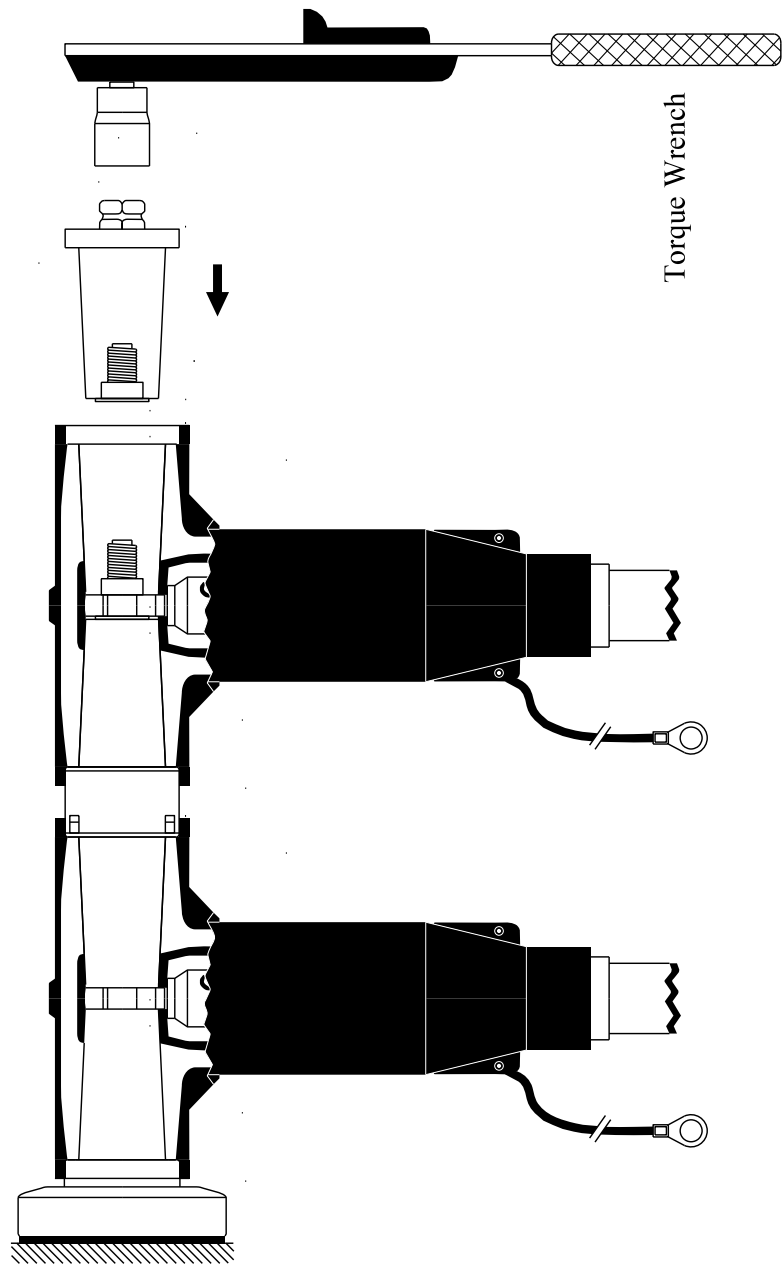



Torque Wrench

Rev No	Drawn	Chk'd	App'd	Date	Revision	
ORIGINAL ISSUE	DATE	WESTERN POWER DISTRIBUTION Design Department. Avonbank, Feeder Road, Bristol BS2 0TB Tel: 0117 933 2000 Fax: 0117 933 2001.				
Drawn	RJB	03/17	Title			
Checked			M440TBG (P2) TEE CONNECTOR BACK TO BACK		Drg. No.	Rev No
Approved					JP3D 7.407.11	
SCALE	N.T.S.					

ALL RIGHTS ARE RESERVED TO WPD (South West) plc. NO PART OF THIS DRAWING MAY BE REPRODUCED OR TRANSMITTED IN ANY FORM OR BY ANY MEANS, INCLUDING PHOTOCOPYING AND RECORDING, OR STORED IN A RETRIEVAL SYSTEM OF ANY NATURE, WITHOUT PERMISSION.

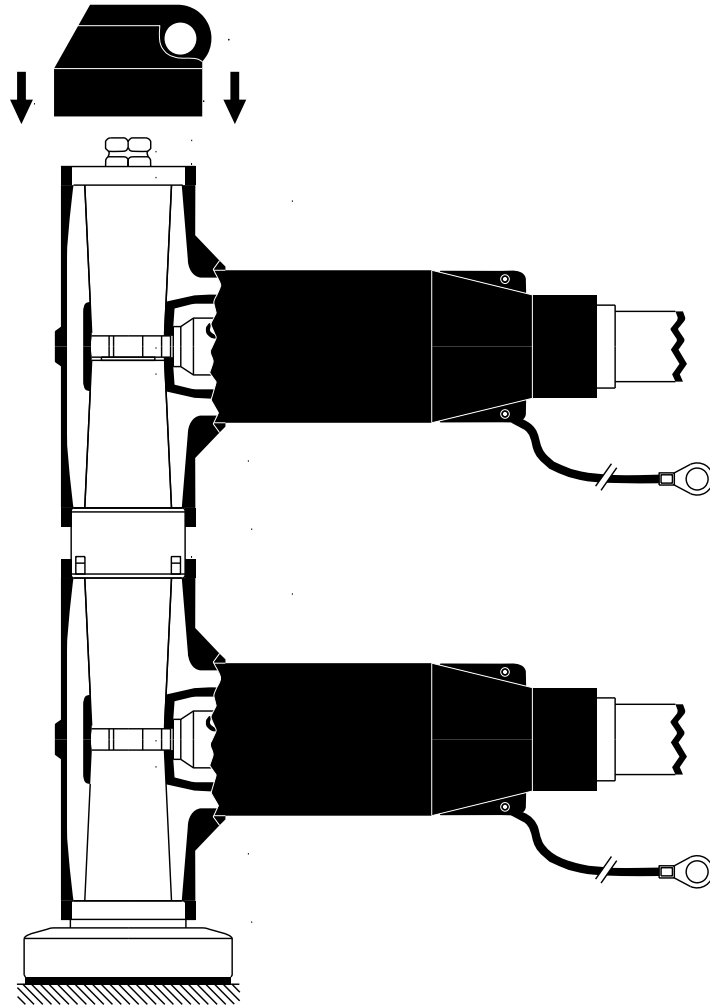
All dimensions in mm



Rev No	Drawn	Chk'd	App'd	Date	Revision	
ORIGINAL ISSUE	DATE	WESTERN POWER DISTRIBUTION Design Department. Avonbank, Feeder Road, Bristol BS2 0TB Tel: 0117 933 2000 Fax: 0117 933 2001.				
Drawn	RJB	03/17	Title			
Checked			M440TBG TEE CONNECTOR TERMINATION TERMINATION COMPLETION			Drg. No.
Approved						JP3D 7.407.12
SCALE	N.T.S.					Rev No

ALL RIGHTS ARE RESERVED TO WPD (South West) plc. NO PART OF THIS DRAWING MAY BE REPRODUCED OR TRANSMITTED IN ANY FORM OR BY ANY MEANS, INCLUDING PHOTOCOPYING AND RECORDING, OR STORED IN A RETRIEVAL SYSTEM OF ANY NATURE, WITHOUT PERMISSION.

All dimensions in mm

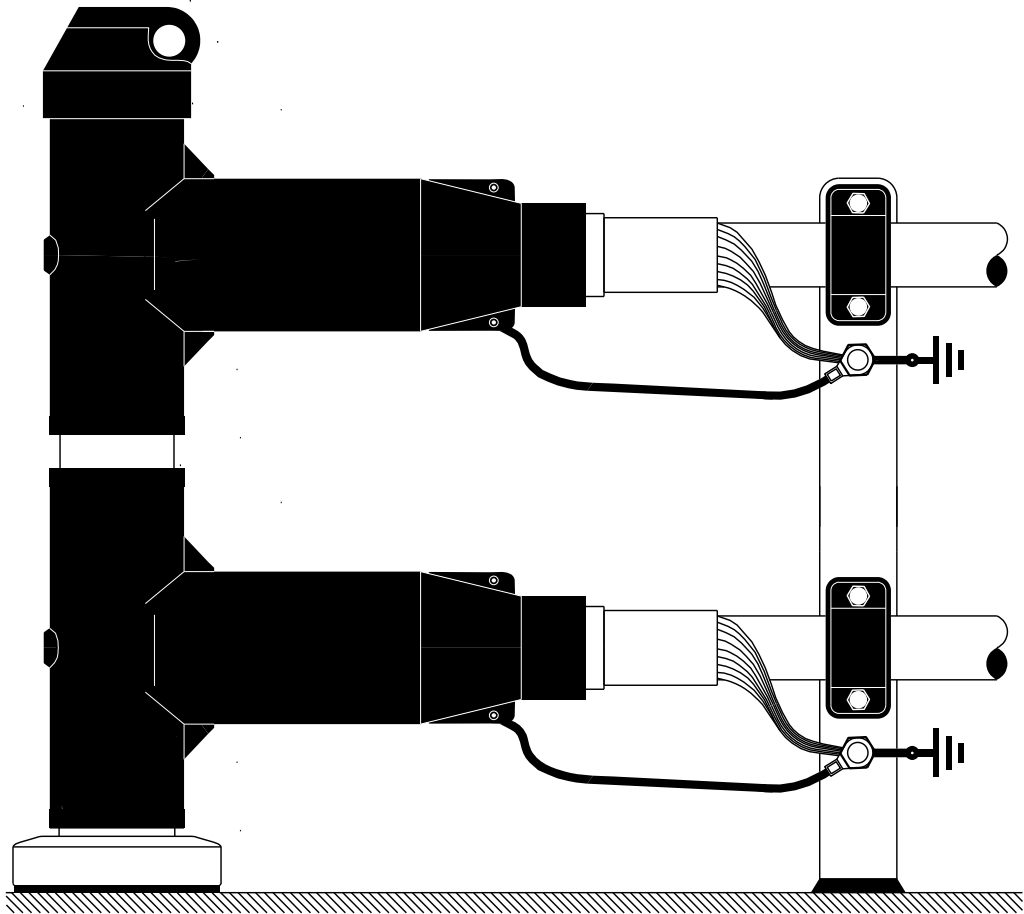

Rev No	Drawn	Chk'd	App'd	Date	Revision	
ORIGINAL ISSUE	DATE	WESTERN POWER DISTRIBUTION Design Department. Avonbank, Feeder Road, Bristol BS2 0TB Tel: 0117 933 2000 Fax: 0117 933 2001.				
Drawn	RJB	03/17	Title			
Checked			M440TBG (P2) TEE CONNECTOR BACK TO BACK		Drg. No.	Rev No
Approved					JP3D 7.407.13	
SCALE	N.T.S.					

ALL RIGHTS ARE RESERVED TO WPD (South West) plc. NO PART OF THIS DRAWING MAY BE REPRODUCED OR TRANSMITTED IN ANY FORM OR BY ANY MEANS, INCLUDING PHOTOCOPYING AND RECORDING, OR STORED IN A RETRIEVAL SYSTEM OF ANY NATURE, WITHOUT PERMISSION.

ST: CA3V/4 PROCEDURES FOR MAKING 33kV CABLE TERMINATIONS

JOINTING PROCEDURE 7.408

**33kV EUROMOLD 400PB-10SA-36/45N INTERFACE C SURGE DIVERTER
SEPARABLE CONNECTOR.**

**This procedure is to be read in conjunction with the appropriate
General Requirements ST: CA3C/3 Section 6
of the 33kV Jointing Manual**

JOINTING PROCEDURE 7.408

TERMINATION KIT MATERIALS LIST

SURGE DIVERTER — 400PB-10SA-36/45N

Item	Quantity
400PB-10SA-35/45N Surge Diverter	3

These surge diverters are on C contract i.e. a call off purchase order needs to be raised on Nexans to get these surge diverters.

Note: - Individual material item numbers (E 5) are to be found in Section 4 of the 33kV Jointing Manual.

JOINTING PROCEDURE 7.408

Actions

General Requirement (ST: CA3C/3)

1. If fitted remove the voltage cap, insulating plug, and clamping screw (retain for later use) --

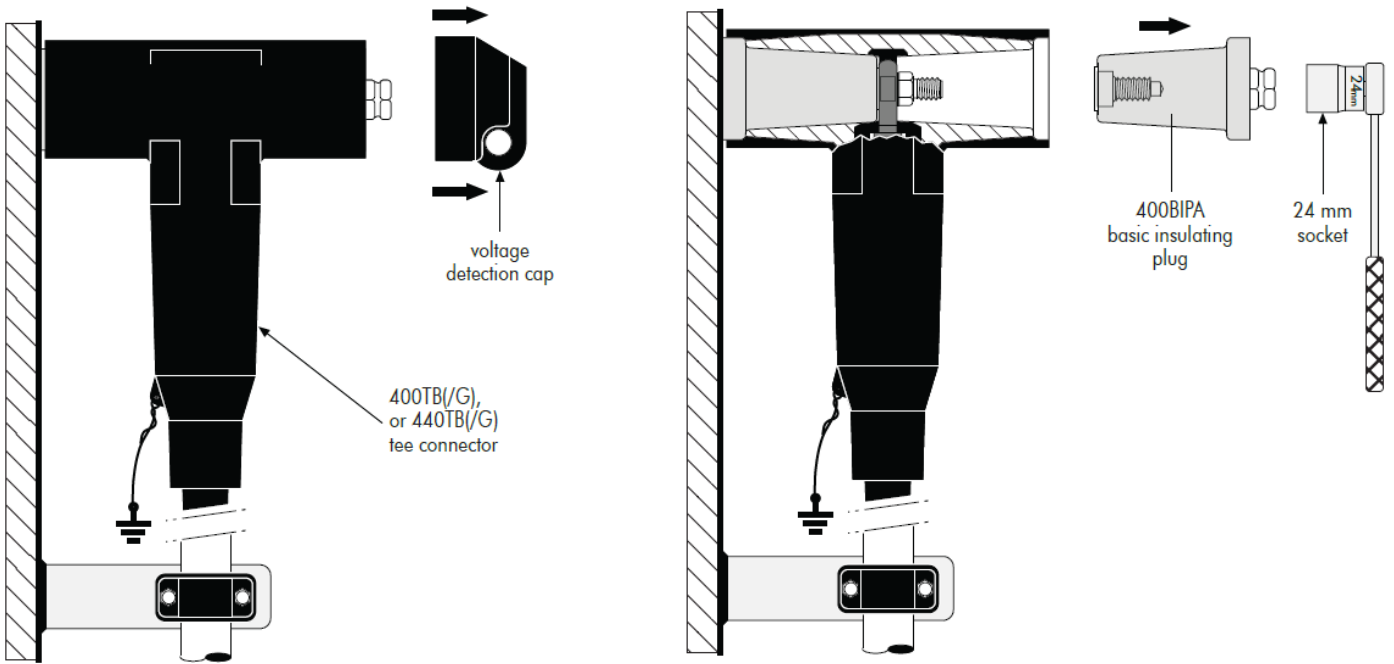

2. Remove the clamping screw and retain for later use --

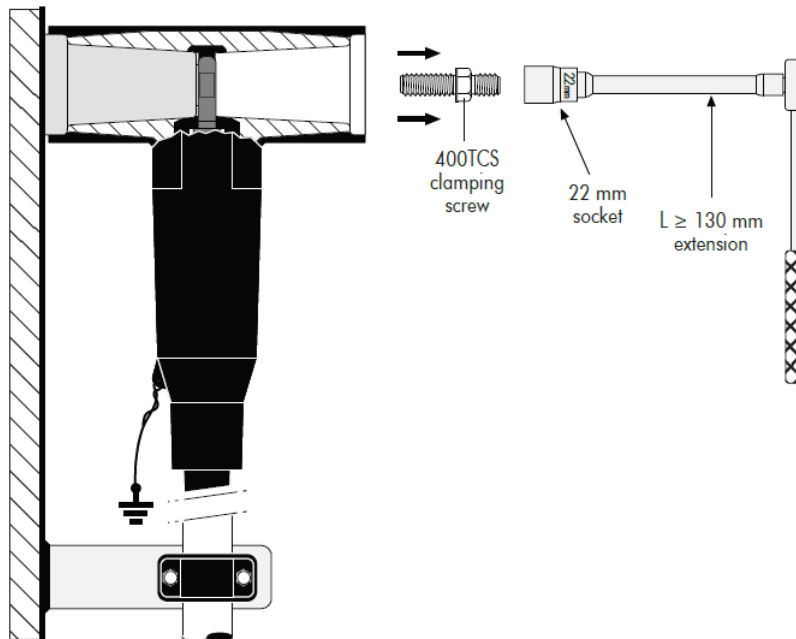

3. Clean and lubricate the inner interface of the tee connector using only the supplied silicone lubricant. --
4. Insert the contact rod (first by hand to ensure the threads are correctly engaged). Tighten the contact rod using a 10mm hex key and torque wrench. **Tighten to 50Nm**. Do **not** contaminate the threaded parts with lubricant. --

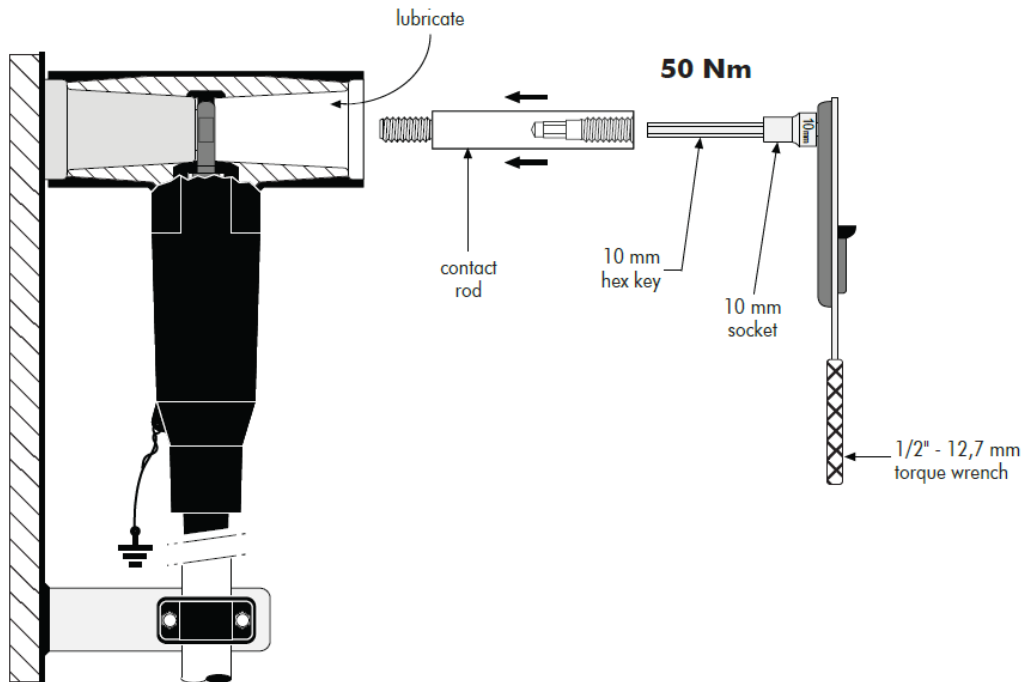

5. Lubricate the male cone of the surge diverter and plug into the back Of the tee connector using only the supplied lubricant --

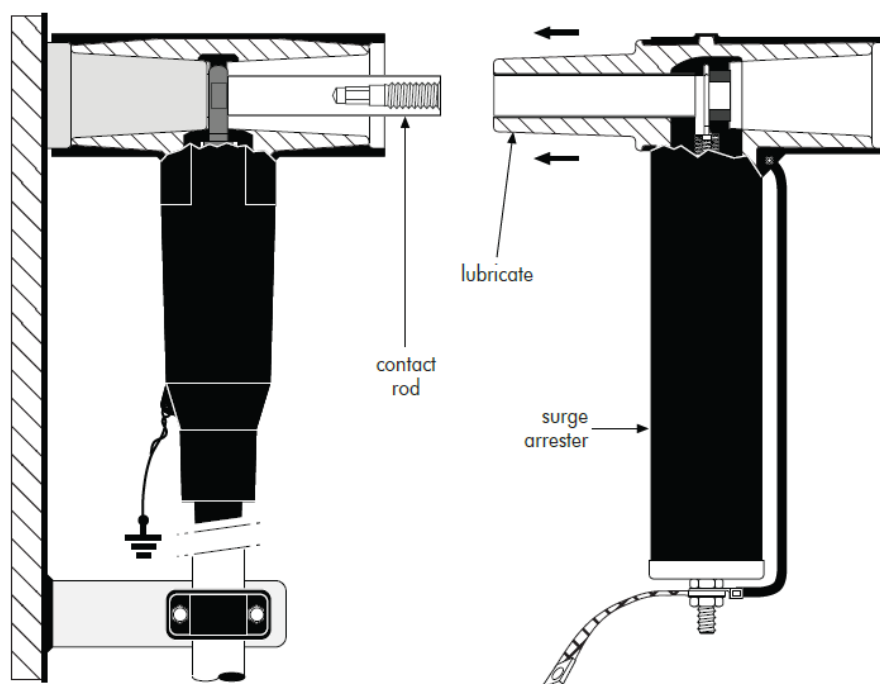

6. Insert the clamping screw (first by hand to ensure the threads are correctly engaged) before tightening to **30Nm** with a torque wrench --

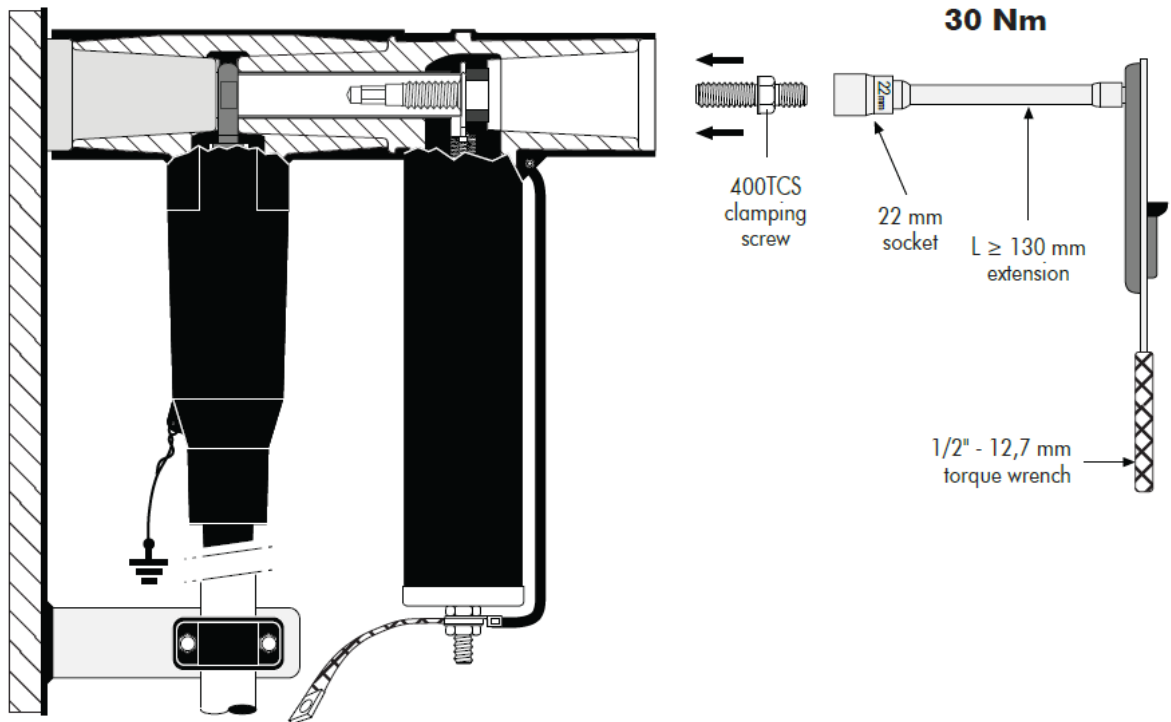

7. Clean and lubricate the inner cone of the diverter and the outer cone of the insulating plug. Insert the nylon vent rod and then screw in the insulating plug (by hand). Tighten the insulating plug to 30Nm before removing the nylon vent rod. --

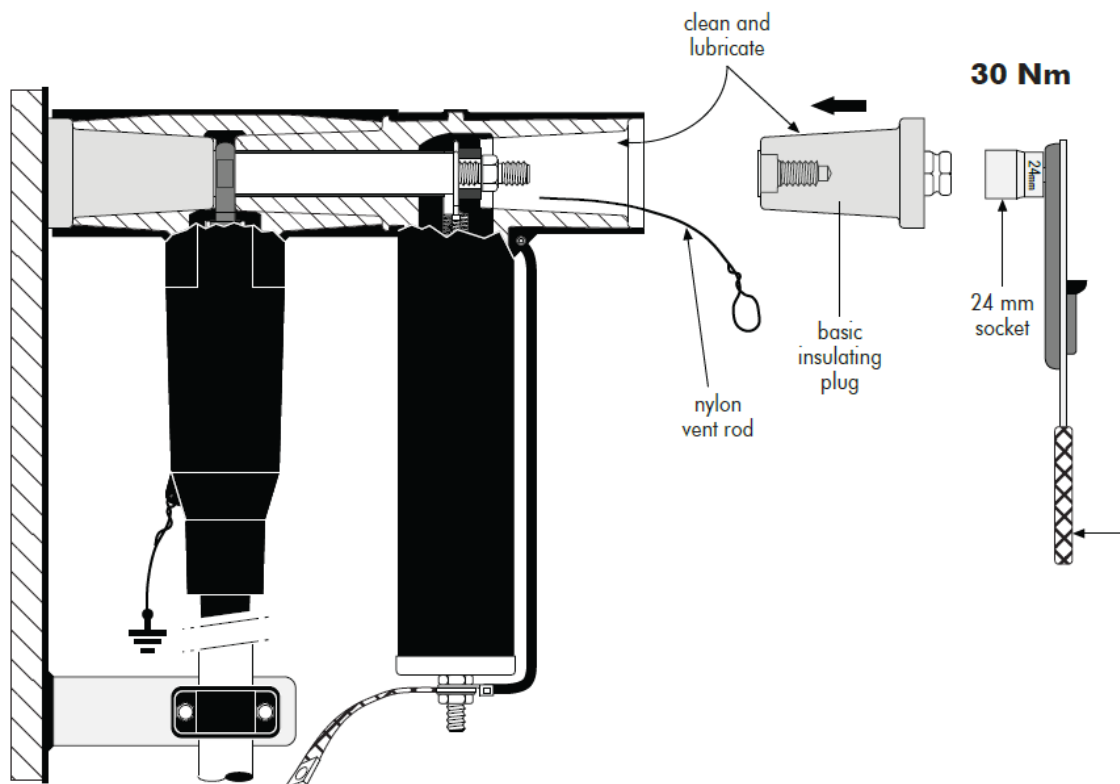

8. Refit the voltage detection cap and connect the earth lead from the surge diverter to earth.

--

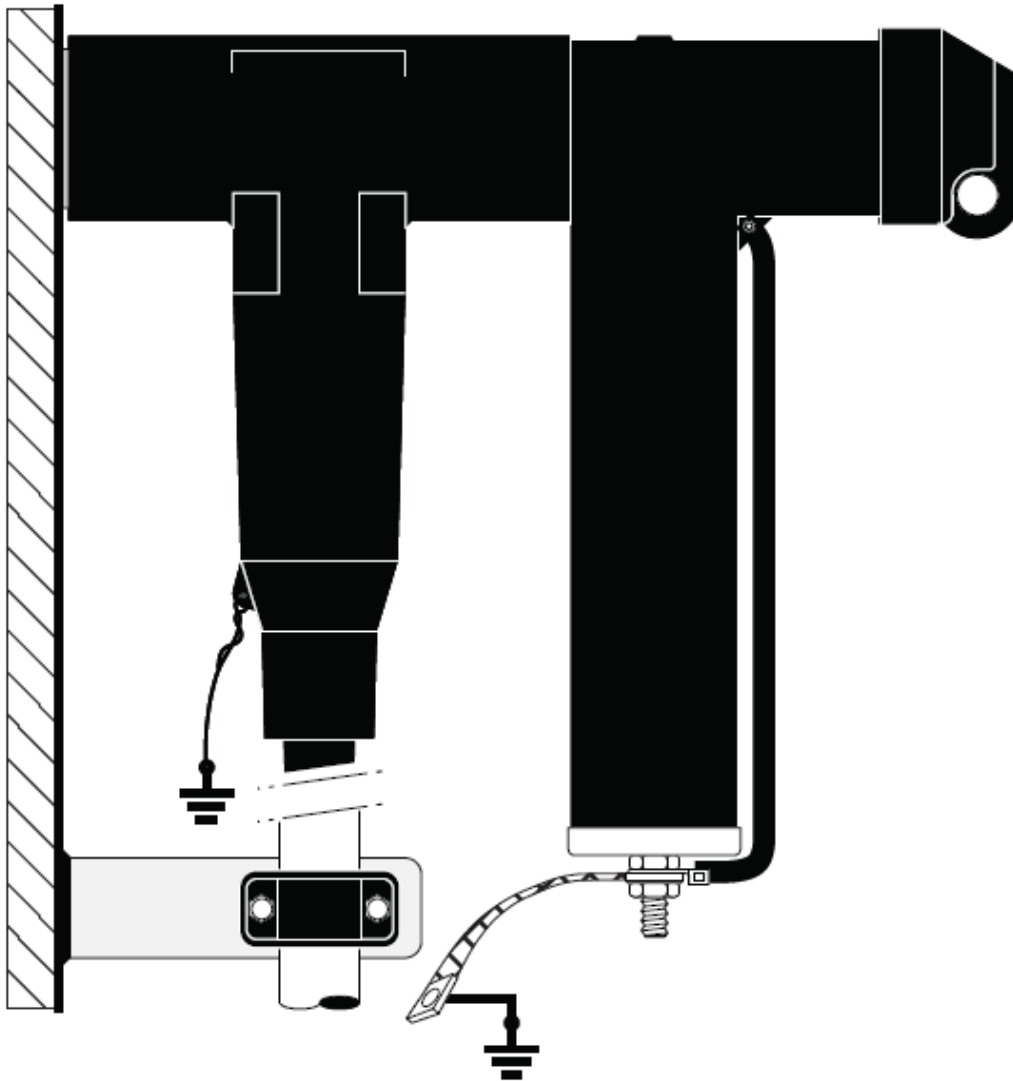

ST: CA3V/4 PROCEDURES FOR MAKING 33kV CABLE TERMINATIONS

JOINTING PROCEDURE 7.409

**185/300 and 400mm² COPPER WIRE SCREEN CABLE 33kV PFISTERER SIZE 3
INNER CONE SEPARABLE CONNECTOR TERMINATIONS.**

Note: - To complete this termination bespoke Pfisterer tooling is required.

**This procedure is to be read in conjunction with the appropriate
General Requirements ST: CA3C/3 Section 6
of the 33kV Jointing Manual**

JOINTING PROCEDURE 7.409

MATERIALS LIST CABLE SIZE – 185, 300 and 400mm² CWS

Cable size 185mm² CWS

Item	Quantity
Pfisterer inner cone size 3 base module (set of 3)	1
Pfisterer 185mm ² cable size module	1
Connector BET120-12 or BET 35-12	1 or 3
Atlas two bolt cable cleat AR2-A12-TB	3

Cable size 300mm² CWS

Item	Quantity
Pfisterer inner cone size 3 base module (set of 3)	1
Pfisterer 300mm ² cable size module	1
Connector BET120-12 or BET 35-12	1 or 3
Atlas two bolt cable cleat AR2-A13-TB	3

Cable size 400mm² CWS

Item	Quantity
Pfisterer inner cone size 3 base module (set of 3)	1
Pfisterer 400mm ² cable size module	1
Connector BET120-12 or BET 35-12	1 or 3
Atlas two bolt cable cleat AR2-A13-TB	3

ADDITIONAL ITEMS FOR EACH JOINT

PVC Tape
De-solvit 1000 FD
Workhorse dry wipes
Emery cloth
Cable ties
Aluminium oxide cloth 320 grit
Aluminium oxide cloth 400 grit

Note: - Individual material item numbers (E 5) are to be found in Section 4 of the 33kV Jointing Manual

Note 2: - To complete this termination bespoke Pfisterer tooling is required e.g. mechanical hydraulic compression tool, size 3 compression head, size 3 impact head and SW6 Torx head screwdriver.

This jointing procedure is only to be used on cables with outside diameter > 58 mm namely:-

Cable Size - CWS	Outside Diameter of cable.
185mm ²	42.5mm
300mm ²	47.5mm
400mm ²	50.8mm

JOINTING PROCEDURE 7.409

Actions	General Requirements (ST: CA3C/3)
1. Ensure cable box dimensions are suitable for termination.	--
2. Identify and mark core phasing clear of termination position.	--
3. Set and align cores into their termination positions.	6
4. Clean each oversheath for a distance of 2m.	--
5. Heat and straighten cores	8
6. Apply a temporary earth continuity bond clear of termination position.	11
7. Park a mastic lined heat shrink tube next to temporary earth continuity bond of each core.	--
8. Park heatshrink tube and pre-assembled bell assembly over cable.	--
9. Set and mark cores into their required positions and mark position (1). <u>This position will be the datum mark for the whole termination</u>	6

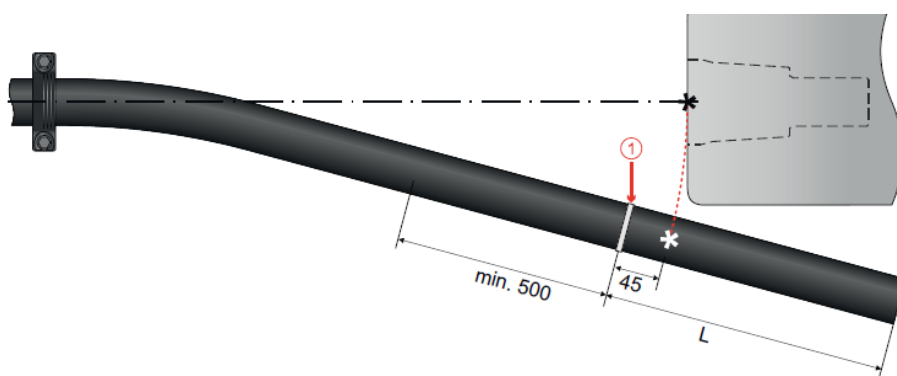

- | | |
|--|----|
| 10. Cut each core to allow sufficient length of copper wire screen to terminate to its earth connection point. | -- |
|--|----|

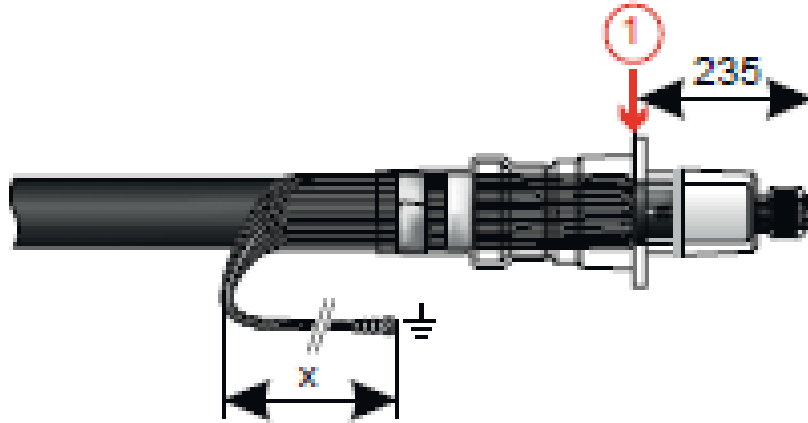

11. From the datum mark (1) previously applied in 9, place a further mark 160mm towards the cable

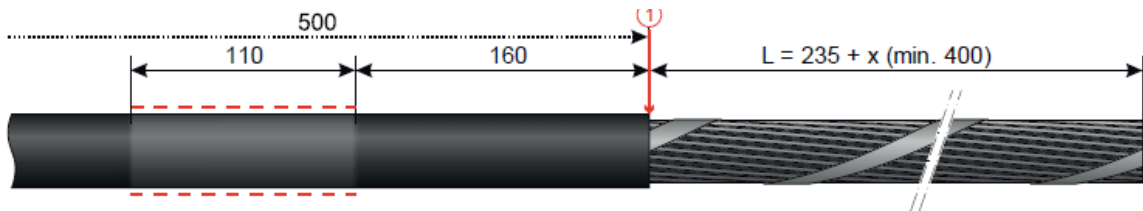

12. Remove oversheath and bedding tapes to datum (1). 17
13. From the oversheath termination mark 160mm --
14. From the datum line measure 270mm (160 + 110mm) and mark the position. Abrade between the two marks 16
15. Degrease the abraded area of 14. 39
16. **Apply a tape control mark at 160mm (to outside edge as shown below)**

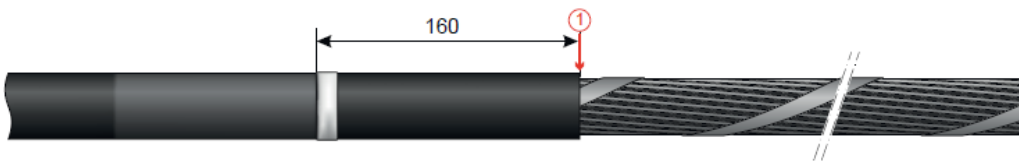

17. Apply a turn of sealing tape 10mm behind the control mark

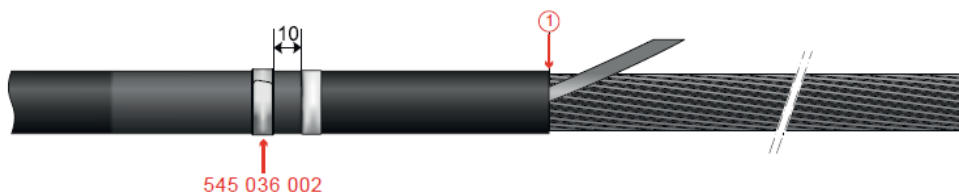

18. At the datum line cut equalization tape from screen wires.

19. Straighten copper screen wires and bend back over oversheath termination ensure copper screen wires are spaced evenly into mastic tape applied in 17 --

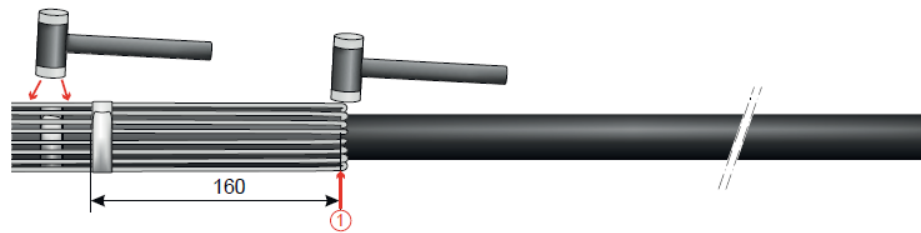

NOTE: - Ensure screen wires DO NOT CROSS EACH OTHER.

20. Fix the copper screen wires in place on the oversheath with the Scotch 88. Position this control mark 160mm back from the sheath cut as shown above --
21. Remove the water swelling tape to the oversheath termination. --

EASI STRIP Semi-Con Screen Only (for bonded screens see 29)

22. Place a mark 235mm from the oversheath termination and cut the cable 24

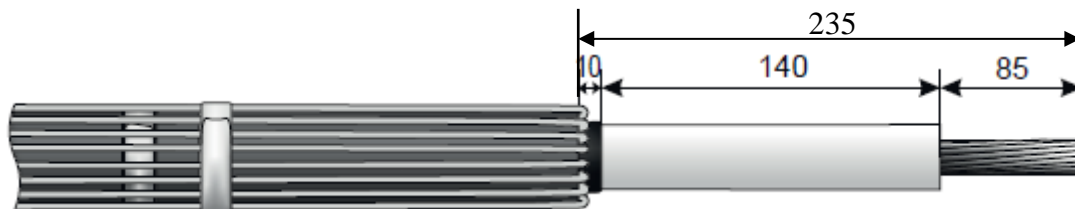

NOTE: - The conductor shall be cut by hacksaw only.

23. Remove insulation screen 225mm from the core end and abrade using Al. oxide (400 grit) 25
24. Chamfer the edge and degrease the insulation. 29
25. Apply adhesive tape (sticky side out) from the beginning of the insulation. Ensure the edge is straight and clean.

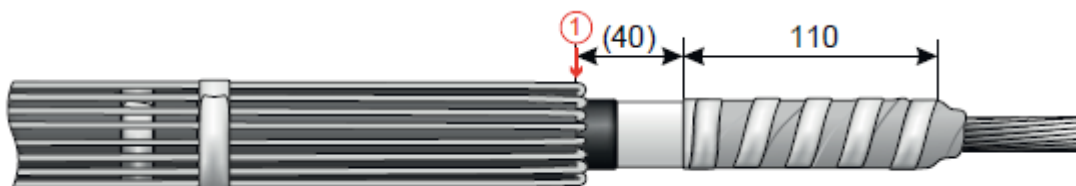

26. Wearing disposable gloves and using a new, clean workhorse wipe apply the dry graphite (Pfisterer part number No. 003 010 011) to the roughened insulation. Allow to dry before buffing off excess with a clean **dry** wipe

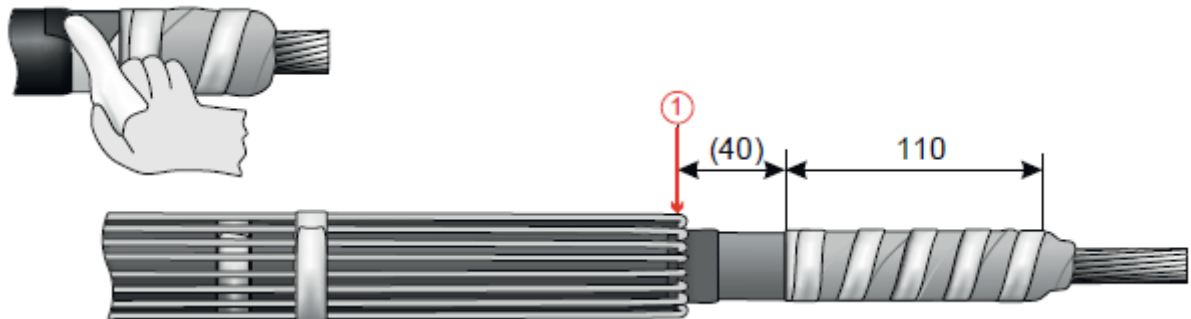

27. Remove protective Scotch 88 tape and proceed to **XXXXX** --
28. Stretch self-amalgamating semi-conductive over the screen termination ensuring that 20mm is applied with a 50% overlap as shown below.

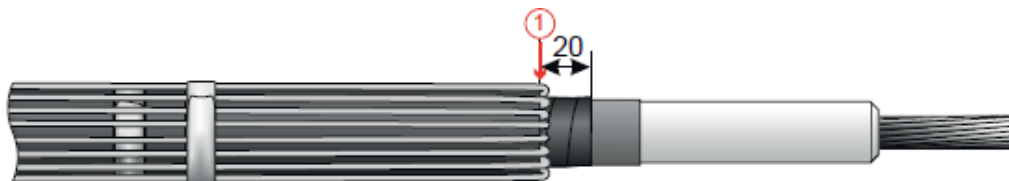

FULLY BONDED Semi-Con only

29. Place a mark 300mm from the oversheath termination and cut the cable 24

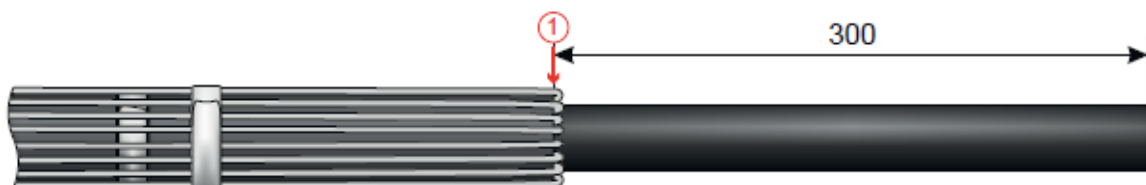

30. In the section between 250mm and 300mm in front of the sheath cut, strip off the screen using the stripping tool. Determine the difference between the diameter of the semi-con layer and the diameter of the insulation.

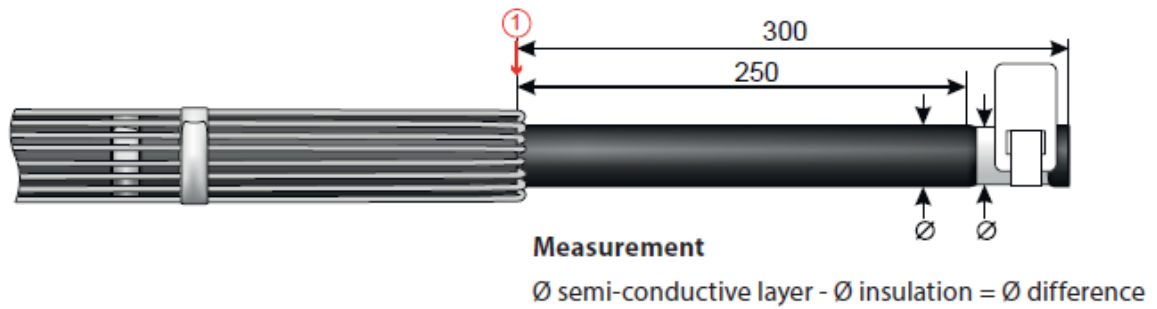

Bonded screen where the difference in diameter is less than 2mm

31. Remove the screen to 40mm from the sheath cut. 29

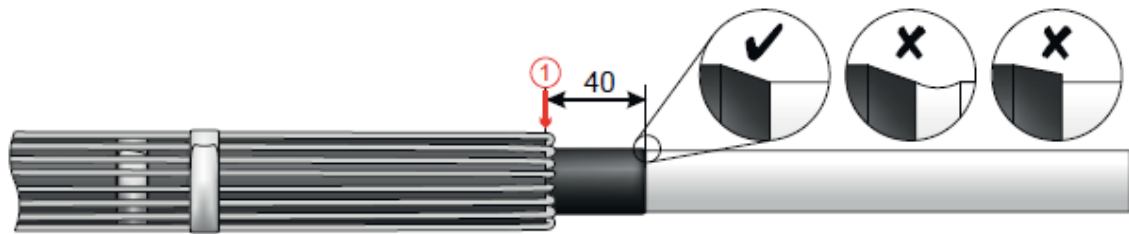

Note for this type of screen no dry graphite is required

32. Cut the core to 235mm from the sheath cut. Remove insulation and chamfer

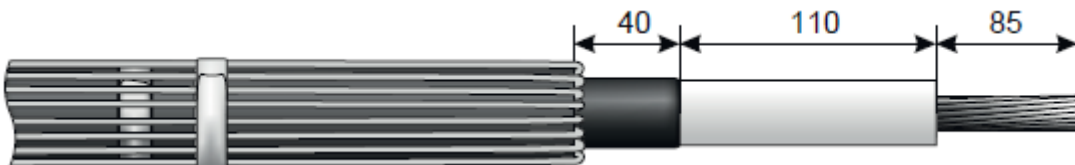

Bonded screen where the difference in diameter is more than 2mm

33. Remove the screen to 20mm from the sheath cut. 29

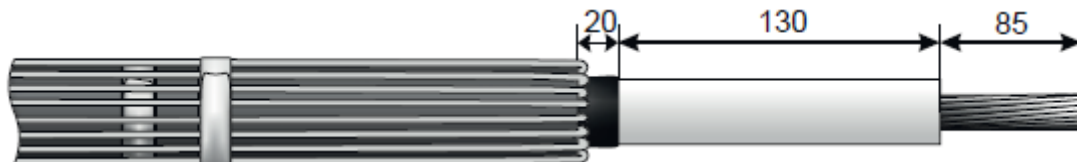

34. Cut the core to 235mm from the sheath cut. Remove insulation and chamfer
35. Apply adhesive tape (sticky side out) from the beginning of the insulation. Ensure the edge is straight and clean.

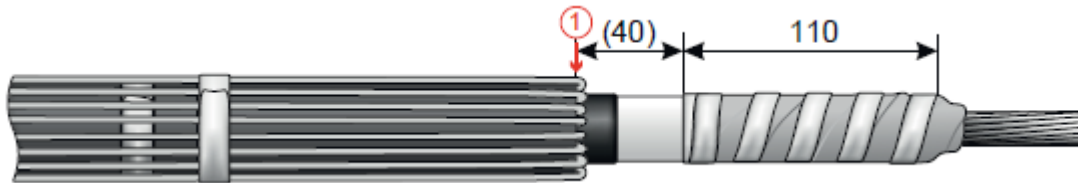

36. Wearing disposable gloves and using a new, clean workhorse wipe apply the dry graphite (Pfisterer part number No. 003 010 011) to the roughened insulation. Allow to dry before buffing off excess with a clean **dry** wipe

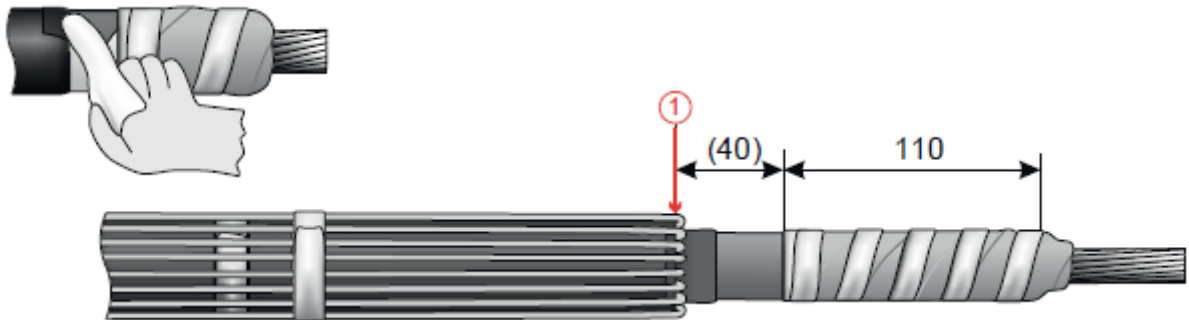

37. Remove protective Scotch 88 tape and proceed to **38** --

38. Park the heatshrink tube and bell flange onto the cable

39. Apply adhesive tape (sticky side out) over the conductive layer (if required). Put adhesive tape over the ends of the strands and apply Pfisterer MV-special grease to the insulation before removing the tape from over the conductive graphite layer.

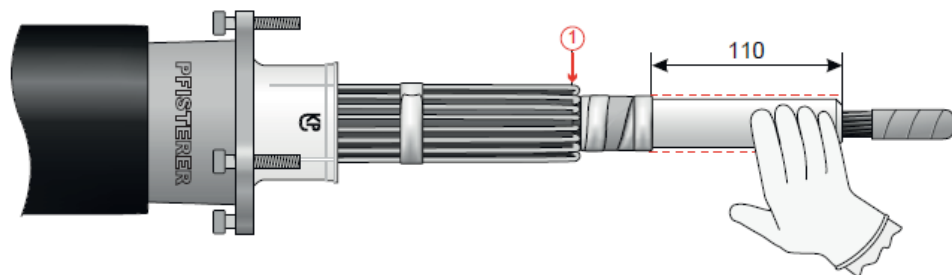

40. Check the insulating part is clean before greasing the inside thinly and evenly with Pfisterer MV-special grease.

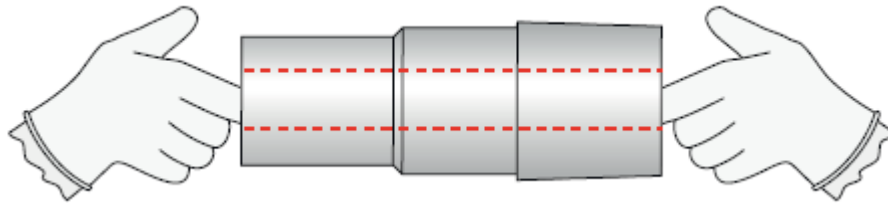

41. Slide the insulating part onto the insulation until 10mm of the insulation is exposed. Remove excess grease.

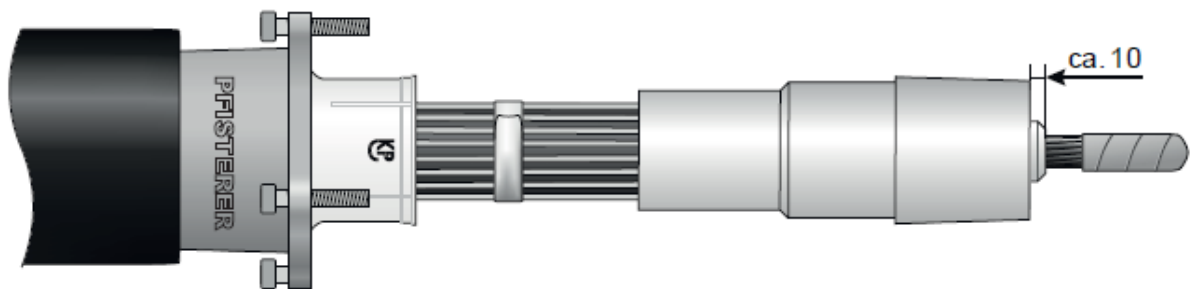

42. Remove the tape from the conductor before sliding on the thrust piece (**rounded side towards the insulating part**) and the tension cone.

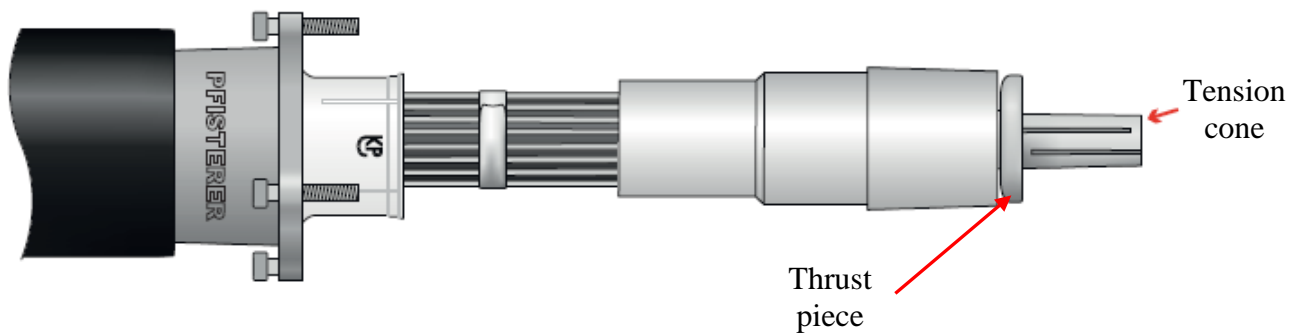

NOTE. The conductor must not protrude out of the tension cone

43. Slide the contact ring onto the tension cone

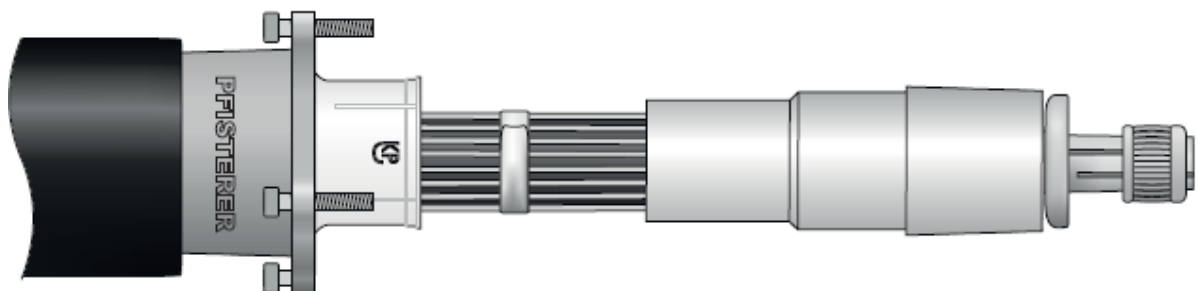

44. Fix the contact ring onto the tension cone with the impact hammer. The contact ring must no longer rotate

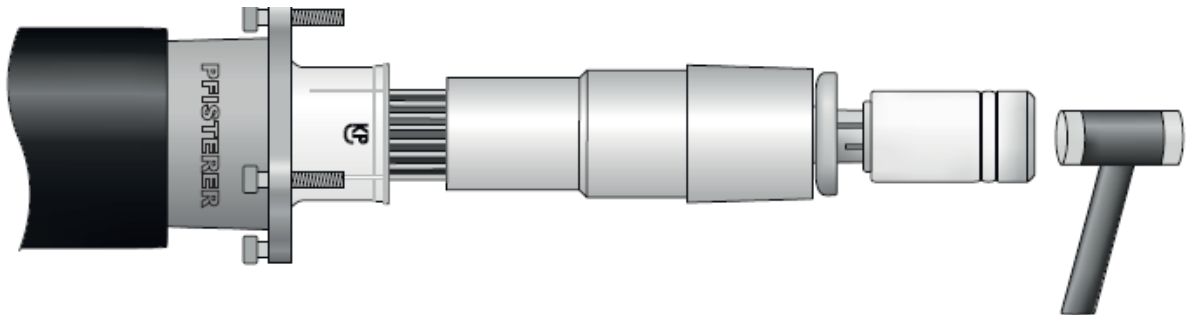

45. Slide the retaining ring of the compression head back and fix the half-shells behind the thrust piece. Do not damage the insulator.

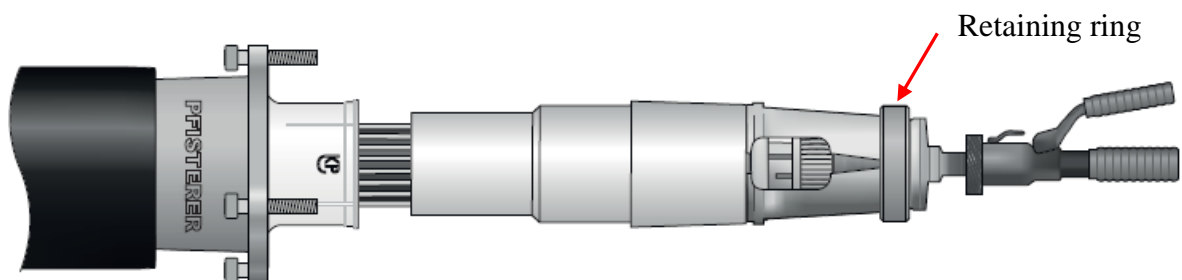

46. Squeeze the half-shells together and slide the retaining ring forwards. Turn the knurled wheel [1] of the hydraulic compression tool to the right until the insert of the compression tool makes contact with the contact ring. Pump the hydraulic compression tool until it reaches pressure. To release use lever 2.

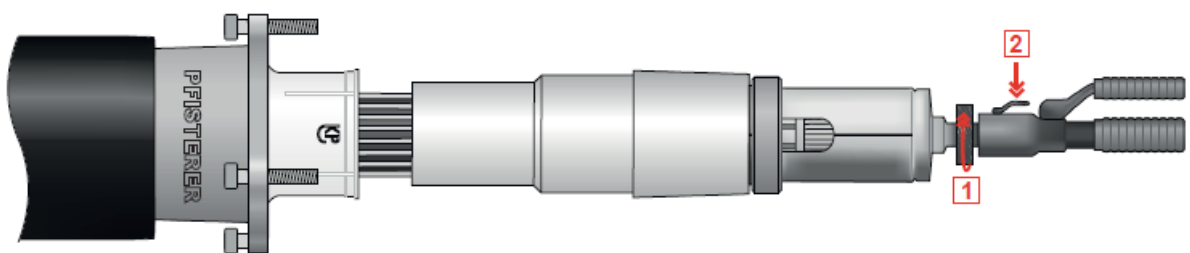

47. Slide the insulating part flush against the thrust piece.

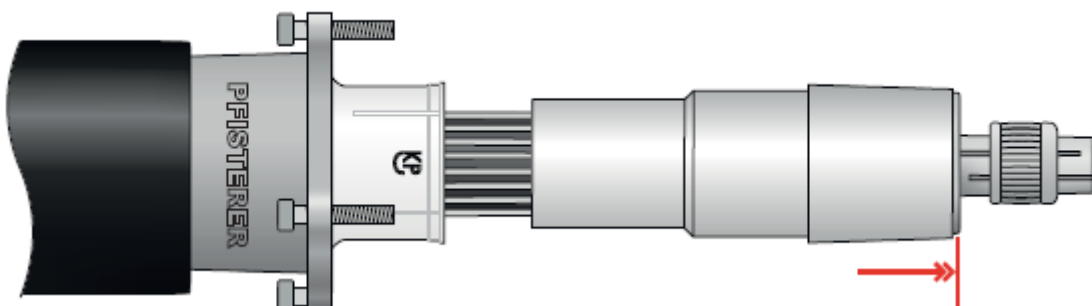

48. Slide the bell flange onto the insulating part.

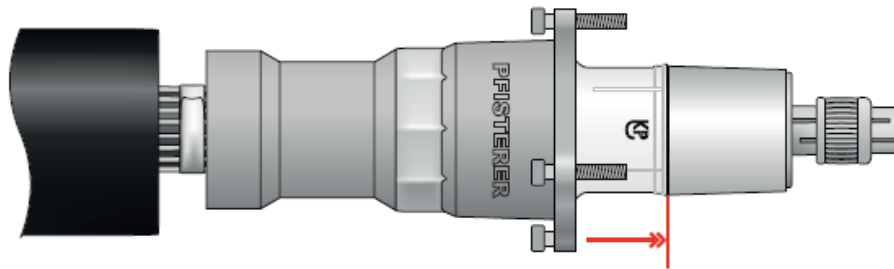

49. Clean the surface of the insulating part and the surface of the socket with De-solvit and grease thinly and evenly with Pfisterer MV-special grease. (wear disposable gloves).

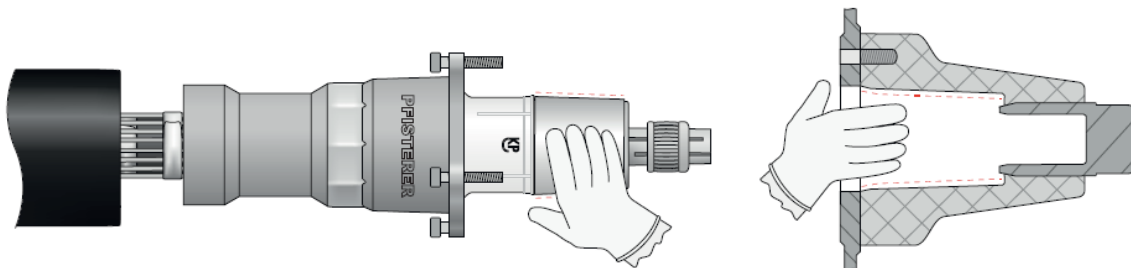

50. Introduce the termination to the socket and tighten the screws. Note the bell flange must be held until the screws grip. Tighten the screws all around with the SW6 T-handled screwdriver (torque 15Nm)

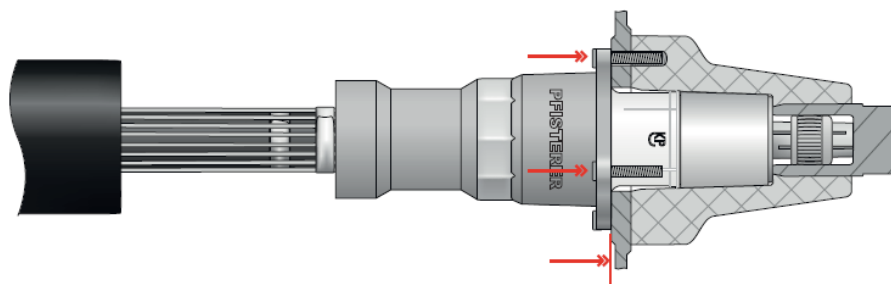

51. Check that you have 207mm to your check mark tape

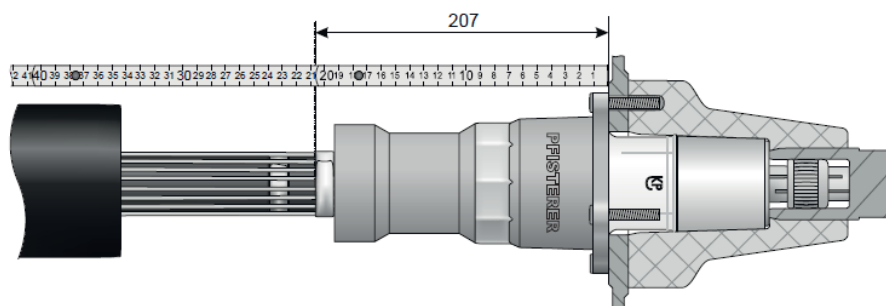

52. Apply another layer of sealing tape directly over the first. Ensure that the voltage tap wire does not cross the screen wires and runs parallel for a minimum of 10mm.

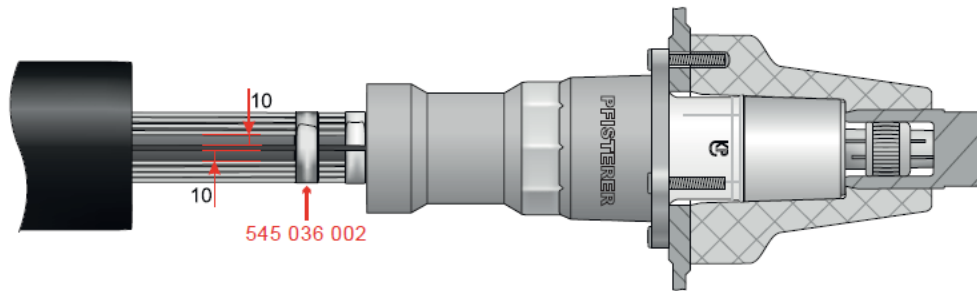

53. Slide up the heatshrink tube and fully shrink down.



NOTE. A setting time of 1 hour is needed before energising

54. Cut the screen wires to the required length and connect to the earth stud. The voltage tap wire should be connected to the constant voltage indicator system. If this is not required it must be connected to earth with the screen wires.

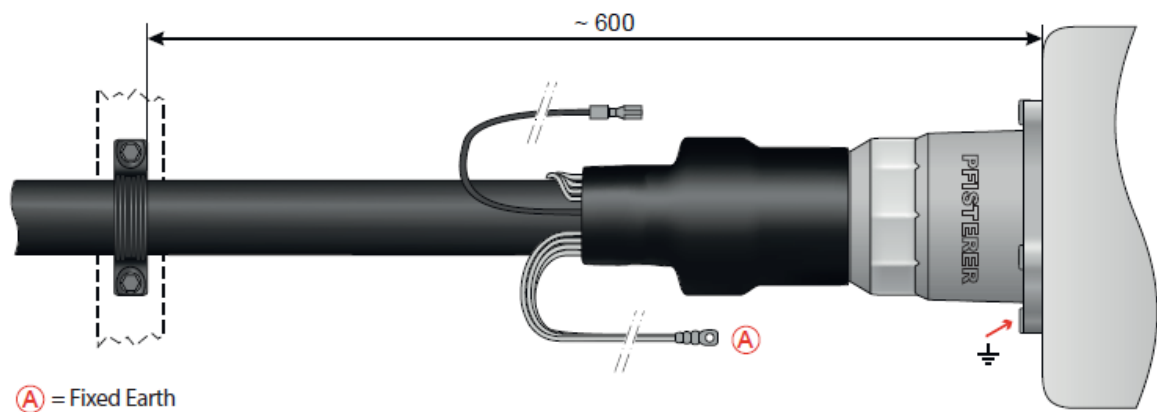

ST: CA3V/4 PROCEDURES FOR MAKING 33kV CABLE TERMINATIONS

JOINTING PROCEDURE 7.410

**630 & 800mm² COPPER WIRE SCREEN CABLE 33kV PFISTERER SIZE 3XL INNER
CONE SEPARABLE CONNECTOR TERMINATIONS.**

Note: - To complete this termination bespoke Pfisterer tooling is required.

**This procedure is to be read in conjunction with the appropriate
General Requirements ST: CA3C/3 Section 6
of the 33kV Jointing Manual**

JOINTING PROCEDURE 7.410

MATERIALS LIST CABLE SIZE – 630mm² CWS

Item	Quantity
Pfisterer inner cone size 3XL base module (set of 3)	1
Pfisterer 630mm ² cable size module	1
Connector BET120-12	1
Compression gland	3
Atlas two bolt cable cleat	3

MATERIALS LIST CABLE SIZE – 800mm² CWS

Item	Quantity
Pfisterer inner cone size 3XL base module (set of 3)	1
Pfisterer 800mm ² cable size module	1
Connector BET120-12	1
Compression gland	3
Atlas two bolt cable cleat	3

ADDITIONAL ITEMS FOR EACH JOINT

PVC Tape
De-solvit 1000 FD
Workhorse dry wipes
Emery cloth
Cable ties
Aluminium oxide cloth 320 grit
Aluminium oxide cloth 400 grit

Note: - Individual material item numbers (E 5) are to be found in Section 4 of the 33kV Jointing Manual

Note 2: - To complete this termination bespoke Pfisterer tooling is required e.g. mechanical hydraulic compression tool, size 3 compression head, size 3 impact head and SW6 Torx head screwdriver.

This jointing procedure is only to be used on cables with outside diameter < 58 mm namely:-

Cable Size - CWS	Outside Diameter of cable.
630mm ²	59.9mm
800mm ²	64.5mm

Note 3: - The cable has to be straight; it needs to be aligned after heating using heating tubes and straightening devices.

JOINTING PROCEDURE 7.410

Actions	General Requirements (ST: CA3C/3)
1. Ensure cable box dimensions are suitable for termination.	--
2. Identify and mark core phasing clear of termination position.	--
3. Set and align cores into their termination positions.	5/6
4. Clean each oversheath for a distance of 2m.	--
5. Heat and straighten the cores.	8
6. Apply a temporary earth continuity bond clear of termination position.	11
7. Park a mastic lined heat shrink tube next to temporary earth continuity bond of each core.	--
8. Park heatshrink tube and pre-assembled bell assembly over cable.	--
9. Set and mark cores into their required positions and mark position (1). <u>This position will be the datum mark for the whole termination</u>	6

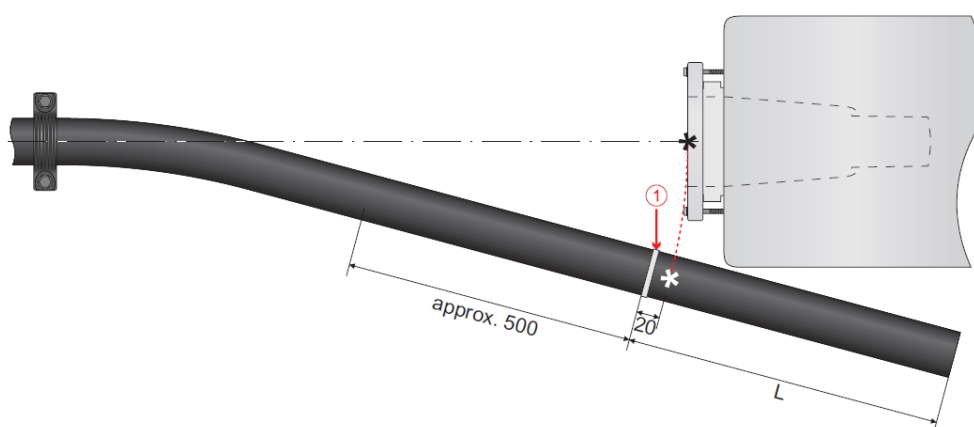

* denotes the screen termination cut position L= min 210mm

- | | | |
|-----|--|----|
| 10. | Cut each core to allow sufficient length of copper wire screen to terminate to its connection point to earth | -- |
|-----|--|----|

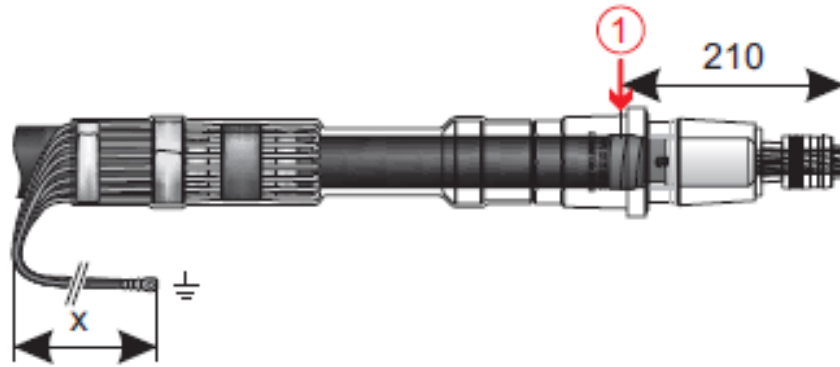

11. From the datum mark (1) previously applied in 9, place a further mark 290mm towards the cable --

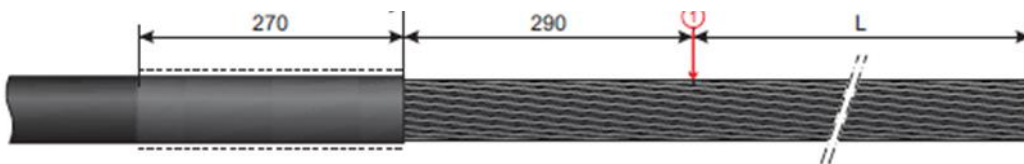

Note: -Position 1 becomes the datum line for the procedure.

12. Remove oversheaths and bedding tapes. 17
13. From the oversheath termination mark 270mm and abrade the oversheath 18
14. Clean the abraded oversheath. 40
15. Apply a turn of mastic tape 390mm from the datum line around oversheath.

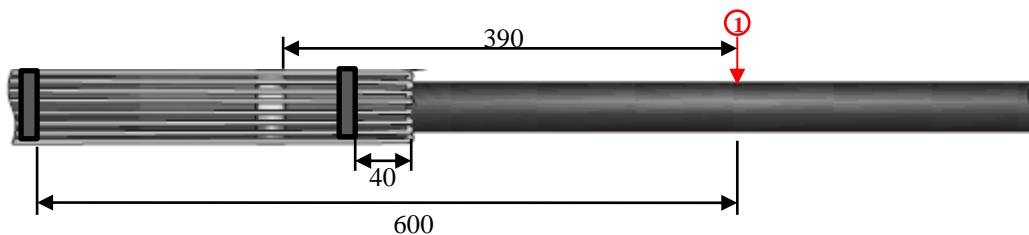

16. Straighten copper screen wires and bend back over oversheath termination ensure copper screen wires are spaced evenly into mastic tape applied. --
17. Hold copper screen wires in place on the oversheath by applying Scotch 88 tape 40mm from the oversheath. --
18. **Important - Place a mark 600mm from (1) the datum mark and apply Scotch 88 tape.** --

19. Apply another layer of sealing tape directly onto the first one to sandwich the earth wires. --

EASI-STRIP Semi-Con Screen Only (for bonded screens see 27)

20. Measure a length of 210 mm from the mark overshath termination (1) and cut excess off with a hacksaw. 27

Note: – do not use cable croppers.



21. Measure 10 mm from the datum mark and remove the easy-strip semi-con screen. **(do not use this measurement for a bonded screen)** 25



22. From the datum position (1) apply a mark to the insulation at 125mm. --

23. Remove the phase insulation to the mark applied in 22. 28

24. Apply Scotch 88 tape to protect the conductor end --

25. From the datum mark (1) measure 40mm onto the insulation apply a mark. --



26. Using a new and clean Workhorse wipe apply the dry graphite (Pfisterer part number No. 003 010 011) to the roughened insulation. --

FULLY BONDED Semi-Con Screen Only

27. At about 300 mm and 400 mm in front of the overshooth termination (1) remove the semi-conducting layer for checking. Then measure the difference from semi-con layer to peeled insulation using the diameter tape. 25



Measure

**OD of semi-conducting layer – OD of insulation
difference < 2 mm means normal semi-con screen.
difference > 2 mm means thick semi-con screen.**

28. Measure a length of 210 mm from the mark overshooth termination (1) and cut excess off with a hacksaw. 27



29. Remove the fully bonded semi-con screen to the dimensions below 25

Screen thickness	Distance From Datum
Up to 2mm	40mm
More than 2mm	20mm



30. From the datum position (1) apply a mark to the insulation at 125mm. --
31. Remove the phase insulation to the mark. 28
32. Apply Scotch 88 tape to protect the conductor end --

FOR BONDED SCREENS THICKER THAN 2mm ONLY

33. From the datum mark (1) measure 40mm onto the insulation apply a mark. --



34. Using a new and clean Workhorse wipe apply the dry graphite (Pfisterer part number No. 003 010 011) to the roughened insulation. --

Completion of the Preparation

35. Remove the Scotch tape from the insulation and apply 3mm chamfer to the phase insulation. --

36. Degrease the phase insulation ONLY. 40

37. Apply crepe paper under slight tension and using half lap layers from the overshooth termination (1) up to the screen wires. --

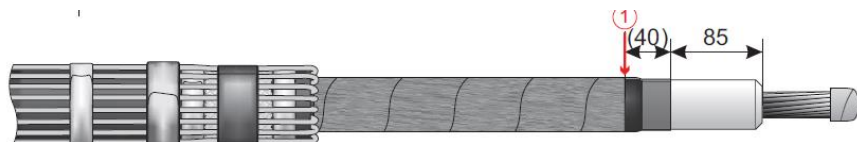

38. Apply copper knit mesh under slight tension and using half lap layers over the crepe paper from the overshooth termination (1) to 20 mm over the screen wires. --

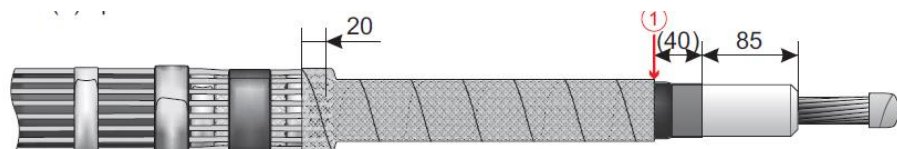

39. **For EASI-STRIP screens only** - Stretch a length of semi-con tape to obtain approximately a half of its original width, apply 2 layers to the dimensions shown below. For easy-strip semi-con screens the edge of semi-con screen must be wrapped

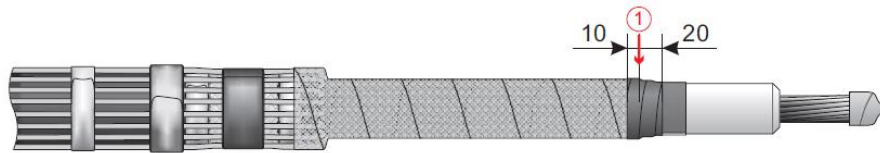

Note: - To prepare the tape take the end and pull to allow the tape to break this will form a thin tapered end, on finishing press on the tape and pull to allow the tape to break, press the thin tapered end down to secure.

Assembly

- 40. Apply Scotch 88 tape with adhesive side outward to the dry graphite. --
- 41. Clean insulation 40
- 42. Apply thin and even Pfisterer MV special grease to insulation. --



- 43. Remove protective wrapping from dry graphite. --
- 44. Check the stress cone is clean and apply a thin and even layer of Pfisterer MV special grease inside --

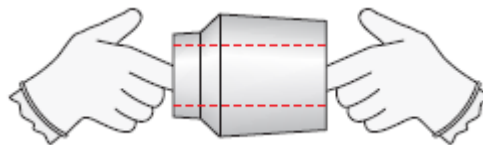

Note: - Only use the silicon grease supplied within the termination kit by the manufacturer.

- 45. Push the stress cone, smoothly and without twisting, onto the core until approximately 10mm of the insulation is protruding beyond the end of the installed stress cone --



46. Remove any excess silicon grease and PVC tapes applied to conductor in 33. --



47. Slide the tension cone onto the conductor --



Note: - Ensure the round surface edge of the thrust piece and the conductor hole recess is facing towards the cable to allow the insulation to fit into the recess, and the rounded edge to fit into the stress cone end recess.

48. Slide the contact ring as far as possible onto the tension cone by hand. --

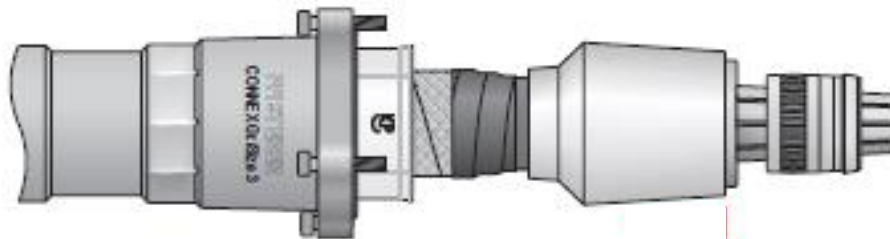

Note: - Check the conductor does not protrude beyond the end of the end of the tension cone.

49. Using the impact device placed over the contact ring, **gently** tap the rounded end to allow a stable and secure fit of the contact ring to the tension cone, the ring should no longer be able to turn --



Note: - The impact head is to be hit only with the palm of the hand.
DO NOT USE ANY FORM OF TOOL.

50. Without twisting, push the stress cone further down the cable in order to allow sufficient space (10mm approximately) to allow fitting of the hydraulic compression tool behind the thrust piece, complete the compression operation --

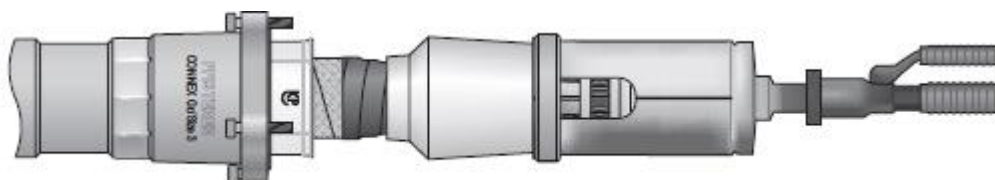

51. On completion of the compression operation, push the stress cone, without twisting back towards the thrust piece until the stress cone and thrust piece meet. --

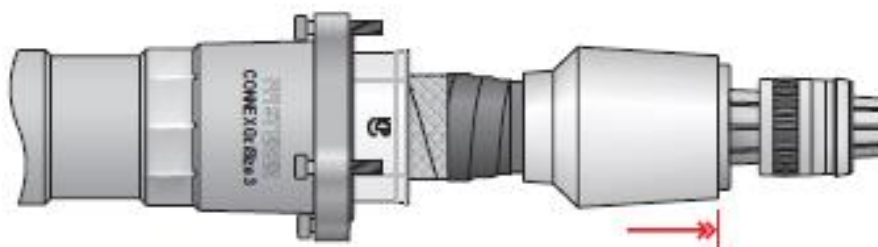

52. Push the bell flange onto the insulating part. --



53. Slide back the conical element from the end of the bell flange. --

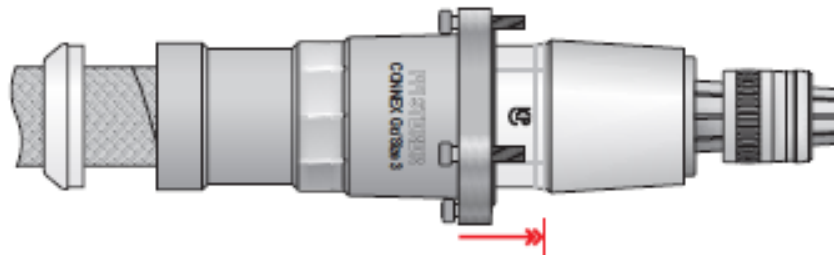

54. Clean the surface of the stress cone and apply a thin and even layer of PFISTER MVspecial grease . Use protective gloves
Note: - Only the silicon grease supplied within the termination kit by the manufacturer is to be used. 40

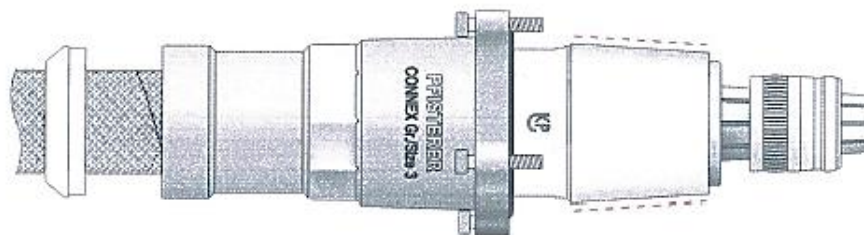

55. Clean the bushing inside. Apply thin and even Pfisterer MV special grease to the inside of the bushing. Use protective gloves --

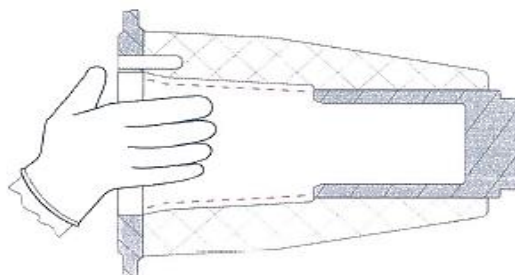

56. Insert the separable connector into the bushing. Ensure the reference line on the plastic inner sleeve of the bell assembly is parallel with the face of the metal flange of the bushing and that the fixing bolts align. --

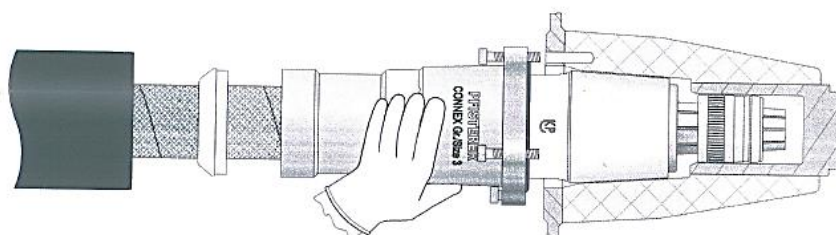

57. Tighten the fixing screws alternately in stages to complete clamping to a torque 15Nm and refit the conical element --

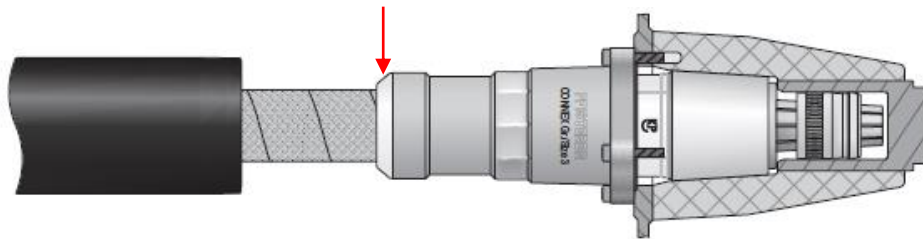

58. Ensure the bell assembly is fitted and secure, position refer to JP3D 7.410.11. --

59. Check the fit of the separable connector: The control mark must be at 620 mm behind the bell flange – or else push the cable to right position. --

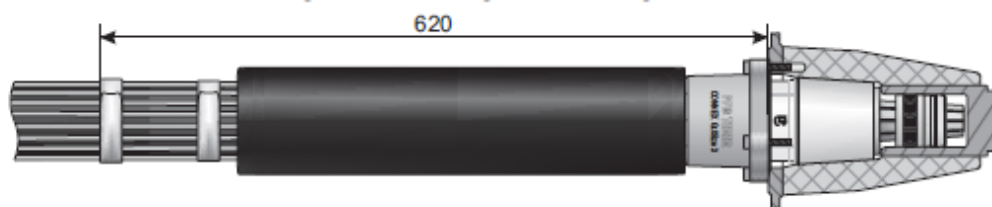

Note: -Leave the control mark on the cable (do not remove it).

Note: -.

60. Shrink the heat shrink tube. Start shrinking at the bell and shrinking down towards the cable --



61. Heat the shrink tubing evenly beginning at the bell flange until it evenly encloses the former and the internal adhesive protrudes on both sides --

62. Form copper screen wires into a bunch terminating into an earth connector, connect to the earth stud/bar refer --

63. **Connect the voltage tap earth lead from the bell assembly to the earth stud/bar.** --

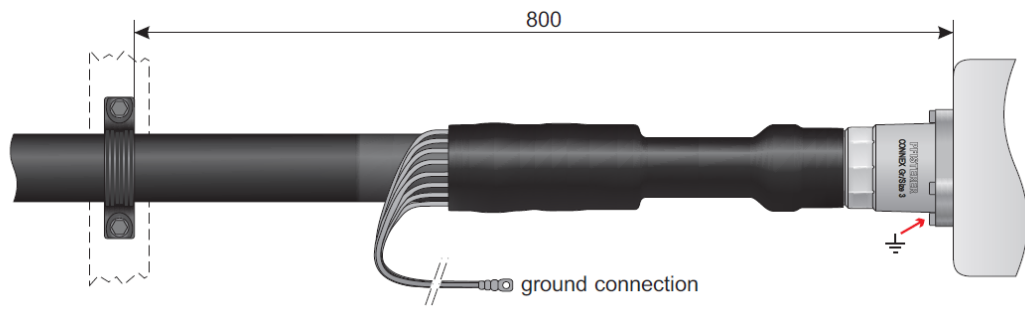

- | | | |
|-----|--|-------|
| 64. | Apply relevant phase identification tape to the cable oversheath refer to JP3D 7.410.12. | -- |
| 65. | Remove temporary earth continuity bond applied in 5 and reseal oversheaths with heatshrink tubes applied in 6. | 11/45 |
| 66. | Fit and secure cables into cable cleats refer to JP3D 7.410.13. | -- |

ST: CA3V/4 PROCEDURES FOR MAKING 33kV CABLE TERMINATIONS

JOINTING PROCEDURE 7.411

INSTALLATION OF PFISTERER SIZE 3 INNER CONE SURGE DIVERTERS.

Note: - To complete this installation no bespoke Pfisterer tooling is required.

**This procedure is to be read in conjunction with the appropriate
General Requirements ST: CA3C/3 Section 6
of the 33kV Jointing Manual**

JOINTING PROCEDURE 7.411

MATERIALS LIST SURGE DIVERTER – 827 537 360 or 450

Item	Quantity
Pfisterer size 3 surge diverters (each)	3
Pfisterer Part number 827 537 360 #	
Pfisterer Part number 827 537 450 – Cornwall only #	

= These two items are on a call off contract with Pfisterer see ST: CA3X for the E 5 numbers.

ADDITIONAL ITEMS FOR EACH JOINT

PVC Tape
De-solvit 1000 FD
Workhorse dry wipes
Emery cloth
Cable ties
Aluminium oxide cloth 320 grit
Aluminium oxide cloth 400 grit

Note: - Individual material item numbers (E 5) are to be found in Section 4 of the 33kV Jointing Manual

Note 2: - Bespoke Pfisterer tools are required to carry out this installation.

JOINTING PROCEDURE 7.411

Actions

General Requirements (ST: CA3C/3)

Refer to Drawings **JP3D 7.411.1** whilst undertaking this Jointing Procedure.

1. Clean the inner area (3) of the equipment interface bushing. --
2. Thoroughly grease the inner area with the special grease provided. --
3. Insert the male section of the surge diverter along with a ventilation hose to bleed the air out of the female section of the bushing. --
4. Remove the ventilation hose and tighten the fixing screws to 15Nm. --
5. Connect the surge diverter to earth via a 35mm² green/yellow PVC cable. --

All dimensions in mm

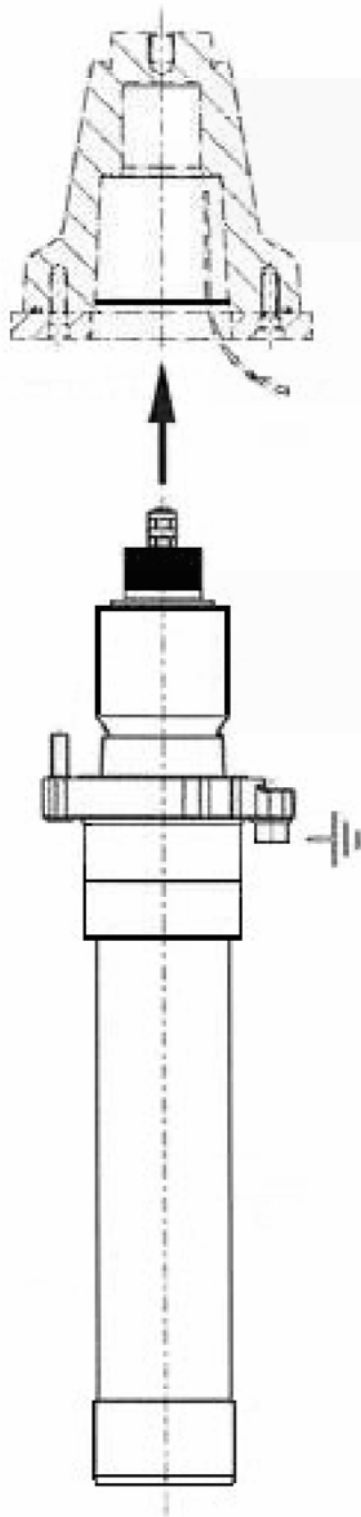

Rev No	Drawn	Chk'd	App'd	Date	Revision		
ORIGINAL ISSUE	DATE	WESTERN POWER DISTRIBUTION Design Department. Avonbank, Feeder Road, Bristol BS2 0TB Tel: 0117 933 2000 Fax: 0117 933 2001.					
Drawn	RJB	01/17	Title				
Checked			INSTALLATION OF PFISTERER SIZE 3 INNER CONE SURGE DIVERTERS			Drg. No.	Rev No
Approved						JP3D 7.411.1	
SCALE	N.T.S.						

ALL RIGHTS ARE RESERVED TO WPD (South West) plc. NO PART OF THIS DRAWING MAY BE REPRODUCED OR TRANSMITTED IN ANY FORM OR BY ANY MEANS, INCLUDING PHOTOCOPYING AND RECORDING, OR STORED IN A RETRIEVAL SYSTEM OF ANY NATURE, WITHOUT PERMISSION.

APPENDIX A

SUPERSEDED DOCUMENTATION

This document replaces ST:CA3V/3 dated August 2017 which should now be withdrawn.

APPENDIX B

ASSOCIATED DOCUMENTATION

ST:CA3A/2, ST:CA3C/3, ST:CA2M/4, ST:CA2N/4, ST:CA2O/3, ST:CA2S/3, ST:CA2T/3, ST:CA2V/4.

APPENDIX C

KEY WORDS

33kV indoor and outdoor terminations, 33kV compound replacement terminations, 33kV load break connectors, 33kV dead break separable connectors.